

5407691 Issue 1 Dec. 2012

SM003482 ~ C00291854



 **Hotpoint**

Built In Integrated Larder Fridges

**Models
Covered**

**Comm.
Code**

**HS2321L
HS2322L**

**54085
77819**

Service Information

Indesit Company UK Ltd

© 2012 Reg. Office: Peterborough PE2 9JB Registered in London: 106725

HEALTH AND SAFETY

For the servicing of refrigeration products, containing Isobutane R600a refrigerant. These instructions are in addition to any other Company procedures already published.

Published primarily for Indesit Company engineers working in the UK or Southern Ireland, for which these instructions are MANDATORY.

1. Only engineers who have been trained on the safe handling of Isobutane R600a refrigerant are authorised to transport, store or carry out system repairs.
2. This manual is not intended as a comprehensive repair/maintenance guide to the appliance.
3. Must only be used by suitably qualified persons having technical competence, applicable product knowledge, suitable tools and test equipment.
4. Servicing of electrical appliances must be undertaken with the appliance disconnected (unplugged from the electrical supply).
5. Servicing must be preceded by earth continuity and insulation checks, plus refrigerant leak detection.
6. Personal safety precautions must be taken to protect against accidents caused by sharp edges on metal and plastic parts.
7. After servicing, the appliance must be rechecked for electrical safety.
8. Smoking, naked flames, or operating gas and/or electrical equipment (including cordless power tools) are forbidden within the storage area, working area and vehicles used to transport Isobutane.
9. The carrying case for the scales and refrigerant must display a red flammability label Part Number 8100063 that should be visible and readable at all times.
10. The vehicle and storage area must be ventilated as far as is reasonably practicable and the aluminium case kept out of direct sunlight. The storage temperature of Isobutane should not exceed 50°C.
11. The vehicle transporting Isobutane (R600a) refrigerant must display a Red Flammable Gas warning sticker (Part No. C00247960 [(8100063)]).
12. Engineers should not wear clothes that are liable to cause static discharge ('electrostatic sparking').
13. Avoid working in small rooms.
14. Do not work in cellars.
15. Whenever possible move the appliance into a larger open area away from possible ignition sources.
16. Request the customer to turn off all other electrical and gas appliances in the near vicinity of the repair and note that it is done.
Customers should be advised to restrict activity within the near vicinity for a short time.
17. Isobutane refrigerant must be vented to atmosphere, (outside of the premises e.g. via open window through the clear plastic hose supplied).
18. Isobutane is heavier than air and must not be vented within 3 metres of the following: sewer cover, cellar, drain or any similar construction lower than ground level, boiler air inlet/outlet, or near any possible source of ignition.

continued...

HEALTH AND SAFETY

19. Working with a naked flame i.e. soldering or brazing is forbidden. Unless otherwise stated, pipework connections must only be made using the Lokring coupling system.
20. Electronic leak detectors with high voltage tips must NOT be used with any Isobutane (R600a).
21. All equipment used for this activity must be checked regularly and maintained in a safe working condition; parts must be replaced as required.

Information Regarding Isobutane Canisters

1. The maximum quantity of Isobutane an engineer should hold or store at any one time is two 1kg net aluminium canisters, supplied individually as Part No. C00218421 (2602600).
2. Canisters must be stored inside the aluminium case with the weighing scales for protection from possible damage and heat. The aluminium case must NEVER be placed next to a heat source or in direct sunlight.
3. Isobutane must only be dispensed to the appliance from the 1kg net aluminium canister placed in an upright position on the weighing scales provided.
4. All used canisters must be returned as scrap and therefore, left out for the driver to collect and return for disposal.
5. Canisters must not be punctured or the internal valve damaged.
6. Before storing the canister it must have the extraction tap valve removed and the internal valve of the canister checked for leakage using leak detector (Leak Detector: Part No. C00222861 (5700043)).
7. All used canisters and those found to be leaking should be exhausted to atmosphere to ensure they are emptied completely. Refer to the following paragraph.
8. Refit the extraction tap if necessary, open the tap and then invert the canister. This must be done outside in open air away from buildings and ignition sources and complying with Item 18 on previous page.

INDEX

Health & Safety Information.....	2 - 3
Introduction.....	4
Technical Specifications.....	5
Overall View.....	6
Autotest Mode.....	7
Replacement Door Seals for Door Assemblies.....	8
Replacing the light Bulb.....	9
Module and Wiring Diagram.....	10
Programming (EMIT).....	11 - 12
Programming Flowchart (Smartcard).....	13
Connecting the Low End Adaptor.....	14
Module Light Sequences.....	15
Installation and Door Reversal Diagrams.....	16

INTRODUCTION

The interior has one fruit and vegetable crisper with a glass cover, four removable, height adjustable shelves, one hinged bottle rack. The door has one removable door shelf with a lid, an egg tray, lidded butter dish, two removable commodity shelves, a compartment for a 2 litre bottle and one removable door shelf for bottles.

The HS2321L model is an over counter 216 litre larder fridge and is manufactured in Italy.
The product was launched November 2008.

The HS2322L is the same as HS2321L, and was launched March 2012.

The electronic thermostat, interior light and light switch are contained in the control box mounted in the top right hand side of the fridge.

Please refer to Technical Specifications for Climate Class and dimensions.

As with many refrigeration appliances it is important that it is installed and operated within the recommended ambient temperature range and that there is also adequate ventilation.

TECHNICAL SPECIFICATIONS

Colour	Polar White		
Introduction Date	HS2321L - November 2008 HS2322L - March 2012		
Mode of Installation	Built In (Integrated)		
Door Hinging	Doors are hinged on the Right Hand side as supplied. The door is reversible.		
Dimensions	Unpacked	Packed	Minimum Aperture
Height	1224 mm	1290 mm	1225 mm
Width	540 mm	590 mm	560 mm
Depth	550 mm	620 mm	550 mm
Weight	36.0 Kg	39.5 Kg	
Total Capacity	Gross: 216 litres Net: 213 litres		
Defrosting	Automatic		
Climate Class	HS2321L - N/ST (+16°C to +38°C) HS2322L - SN/N/ST/T (+10°C to +43°C)		
Energy Consumption	HS2321L - to 1998 Regulations 161 kWh / year 0.44 kWh / 24 hours HS2322L - to 2011 Regulations 138 kWh / year 0.38 kWh / 24 hours		
Energy Band	HS2321L = A HS2322L = A+		
Compressor	Electrolux	Embraco	
	HTK70AA	EMX26CLC	
Winding Resistances:	Start = 24.6 Ohms	Start = 24.6 Ohms	
	Run = 28.1 Ohms	Run = 28.1 Ohms	
Mains Cable Length	2 metres		
Electrical Supply	240 Volts AC @ 50 Hz		
Refrigerant Charge - R600	Refer to Rating Plate		

OVERALL VIEW - refer to illustration below

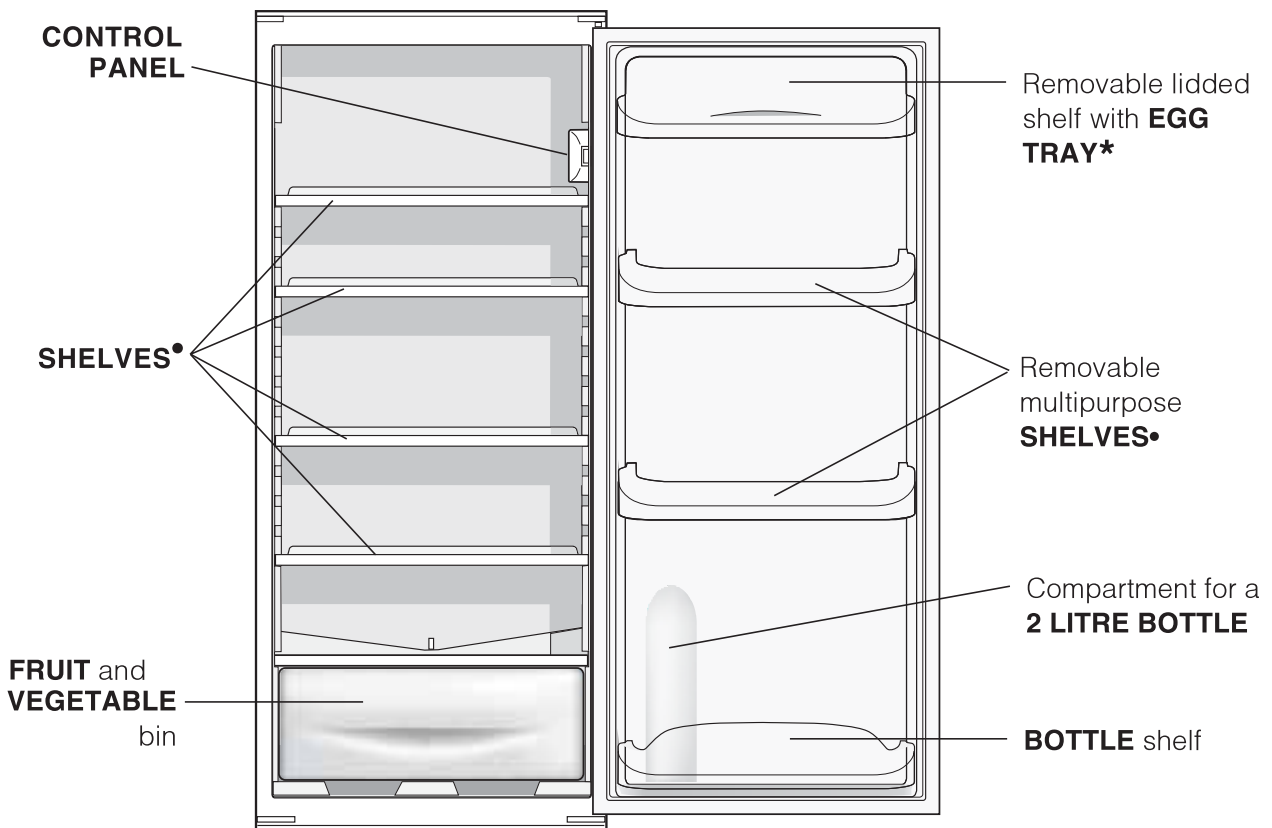
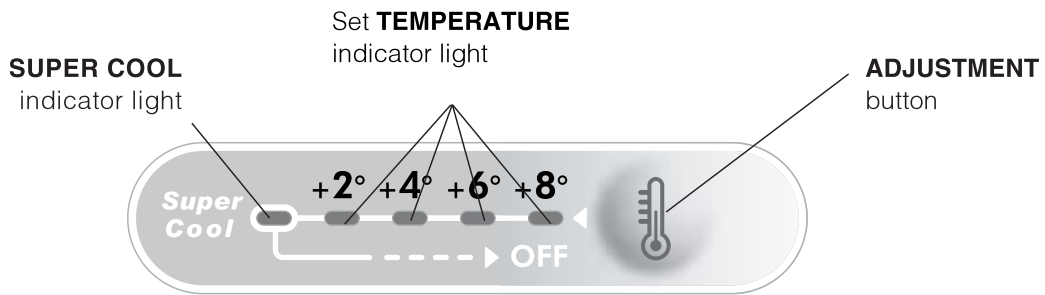

- Varies by number and/or position.
- * Available only on certain models.

AUTOTEST MODE

Autotest Function:

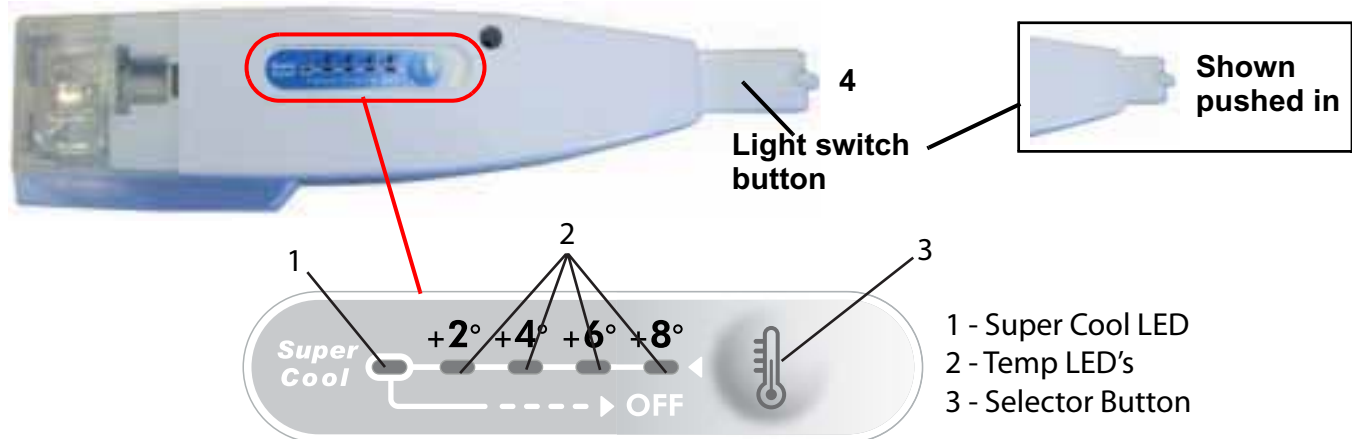

To start Autotest:

- With the Fridge Door open, push and hold in the Light switch button (light Off position). See item 4 above.
- Press and hold the "3" key (see above) on the control panel for 5 seconds. The test sequence will begin.

Autotest Sequence:

All LEDs on the control panel are off during the AUTOTEST procedure.

At the end of the AUTOTEST the appliance returns to the "ON" position at a temperature of + 4°C.

Press the button on the control panel or unplug the appliance to stop the AUTOTEST procedure.

Step	Duration	Action	Light	AIR Fan	Notes
1	5 sec	Pause	OFF	OFF	--
2	1 sec	Check probe	OFF	OFF	If probe is faulty go to Step 3 If probe is OK, go to Step 4
3	249 sec	Activate AIR Fault error message	Interior light blinks	ON	End of autotest procedure
4	249 sec	Activate AIR Probe OK message	ON	ON	End of autotest procedure

Alarm Messages:

There is only one alarm message: **NTC** short circuited / open. **Alarm on:** refrigerator light blinks. The alarm is only signalled during the autotest.

Temperature Alarm:

The temperature alarm (indicated by the flashing set temperature LED and a buzzer) comes on automatically when the **NTC** probe measures a temperature of above 10°C for more than 30 minutes.

Reset Temperature Alarm:

If a temperature alarm has been generated, press the ON/OFF / SET TEMPERATURE key, (the only key on the control panel) to reset the alarm and make the product switch to OFF state.

REPLACEMENT DOOR SEALS FOR DOOR ASSEMBLIES

Various types of door seal are supplied as replacements. See Figs. A, B and C showing seal profiles. Note also the liner profiles A5, A6 and B5, B6 below.

The door seal, Fig. A, is retained by the liner which has 2 screws securing each corner.

The door seal as illustrated in Fig. B is not available as a spare part, but the seal as shown in Fig. C is supplied as the replacement.

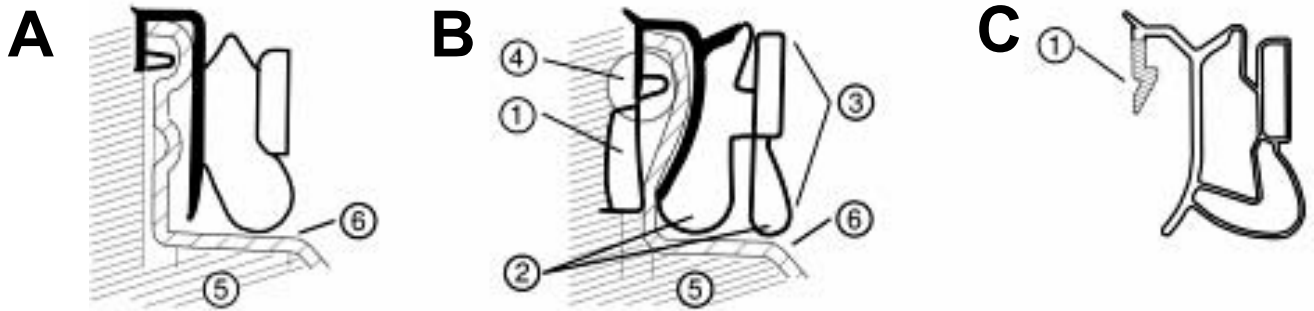

Removing the Old Door Seal - See Figs. D to L.

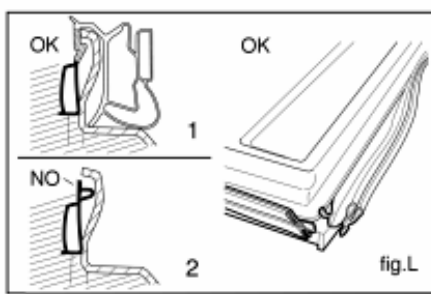
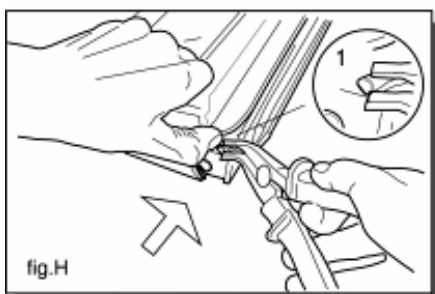
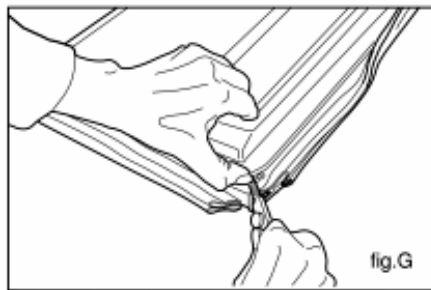
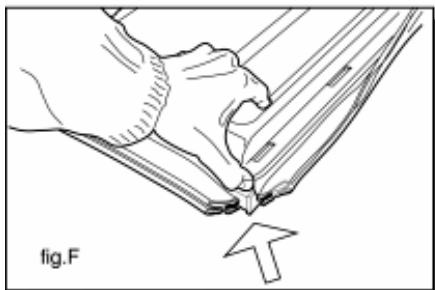
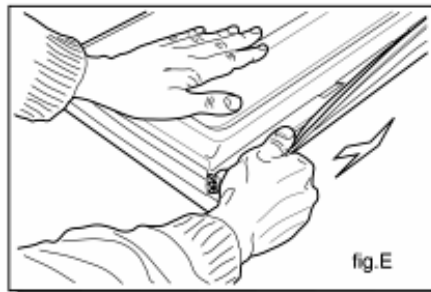
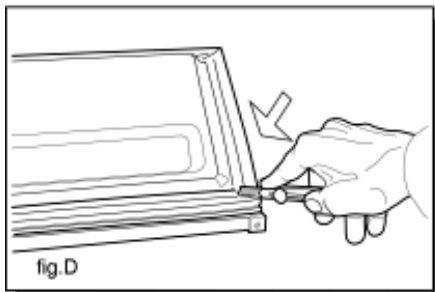

Remove the door from the appliance and place on a flat protected surface. Cut the seal across each corner (including the rigid tongue section retained by the liner). Each section can then be withdrawn from the liner using snipe nosed pliers and pulling. Where the seal is particularly tight in the liner slot, it might be helpful to ease the edge of the liner away from the door panel using a wide bladed screwdriver or chisel knife, Part No. C00222502 (5500012). Similar practice should be adopted when fitting the replacement seal.

Once the seal is removed and the liner seal pocket is empty, it can be helpful to insert the chisel knife between the liner / door panel and slide it around the door to clear any debris.

Fitting the Replacement Seal

Insert the replacement door seal rigid tongue between the liner and door panel and push into position, Fig. B. It may be necessary to insert a chisel knife between the liner and door panel to get the seal started.

Replacing the Light Bulb

To replace the light bulb in the refrigerator compartment,

1. Pull out the mains plug from the electrical socket.
2. Access the light bulb by removing the cover as indicated in the diagram below.

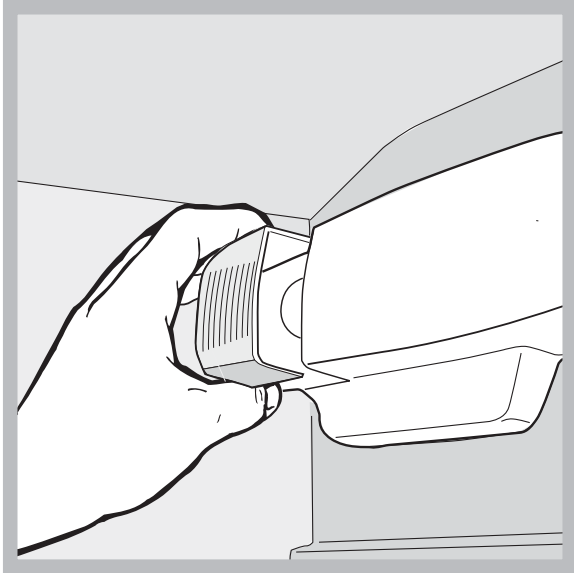

3. Unscrew the faulty bulb.
4. Replace it with a similar light bulb within the power range indicated on the cover (10 Watt or 15 Watt).

Module and Wiring Diagram

Key:

- AC: Alternating current
- LF: Refrigerator light
- MV: Motor fan
- CO: Compressor
- PT: PTC relay
- RH: Circuit breaker
- PR: Refrigerator light button/ magnetic reed switch
- S: Probe
- C: Start condenser (where installed)
- LZ: Freezer light
- RC: FZ frame resistor (where installed)

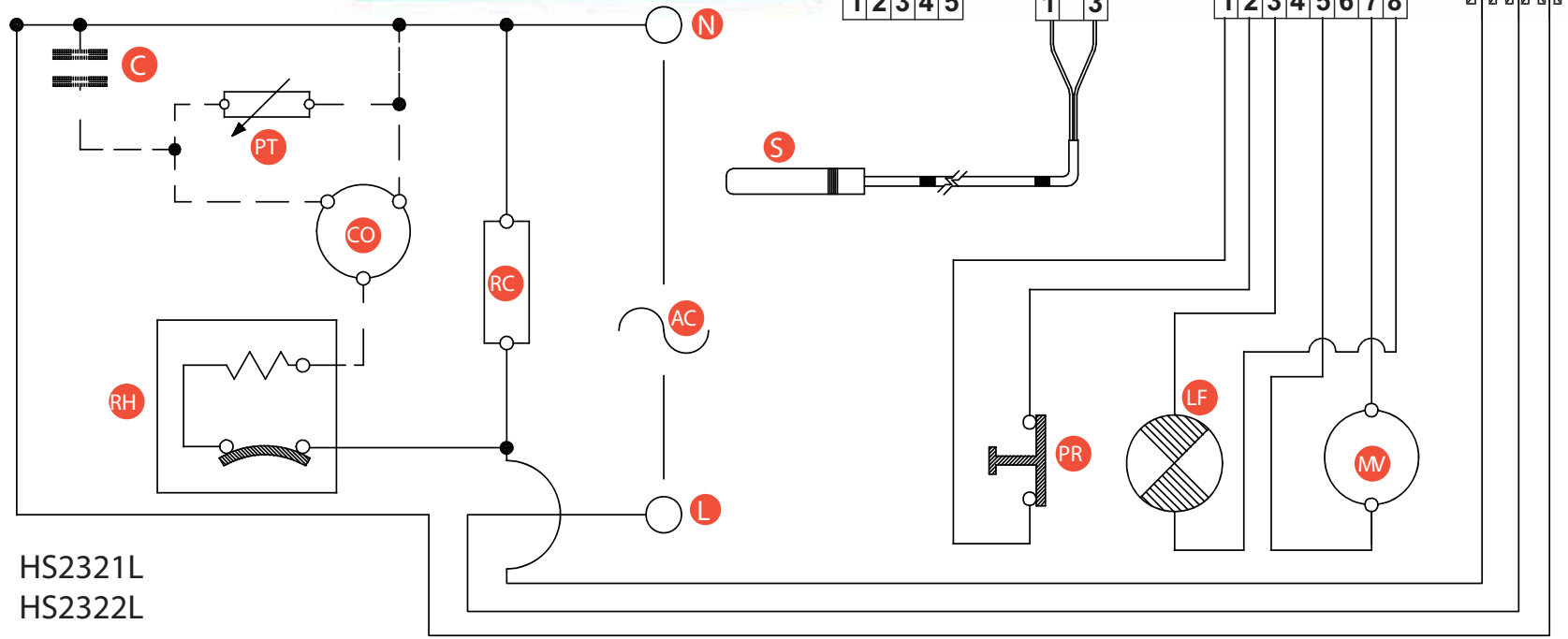
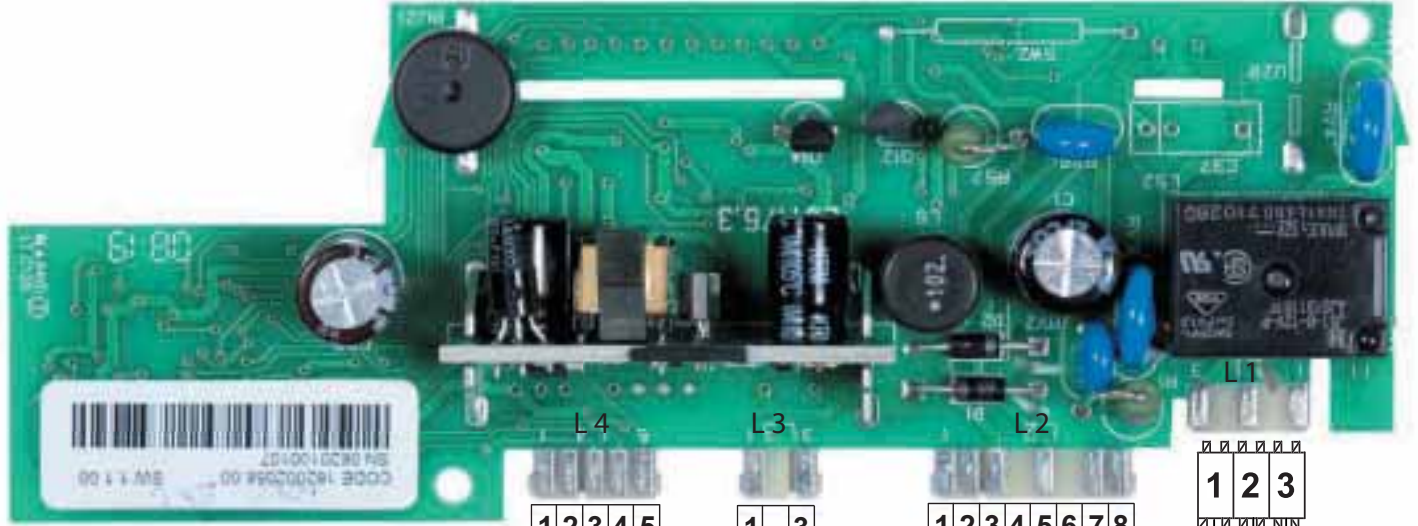

HS2321L
HS2322L

PROGRAMMING (Using EMIT)

This machine can be programmed via the Emit, using a USB lead (Part number C00222800), Hardware key (Part number C00115587) and the Memwriter software.

Black Serial Hardware Key



USB - Serial Cable Other types of Cable are available



Replacement pins for the Serial Hardware Key are available as Part No. C00114723 (Qty = 1)

The Black Hardware Key and USB Serial Cable will be replaced with a new style Hardware Key and Cable which now has a USB connection. It has shorter, more robust pins, similar to those currently fitted into the SmartCard Reader. It is not possible to mix old and new cables or keys.

NOTE: - ** The USB Hardware Key also supports a low voltage connection point which allows an external power supply to be connected to the Hardware Key which enables the main module to be programmed with a settings file prior to fitting it to an appliance. ** **This is NOT applicable to UK Service Engineers. Do not connect anything to this connection point.**

USB Hardware Key - C00289048 & Cable C00289046



USB Cable
C00289046



Low Voltage
Connection Point
(do NOT use)

USB Connection

MAIN BOARD PROGRAMMING

NOTE: The module does not have a physically replaceable EEPROM.

Programming a Main Board

There are a number of ways the board can be programmed - some of which are not applicable to certain markets.

Types of programming:

1. Handheld Terminal (Not UK)
2. Emit / Memwriter (UK Indesit Service Engineers)
3. Smart Reader and Smart Card (certain areas of UK market) see photo.

Smart Card Reader



Smart Card

this card holds the program file and can only be used ONCE.



PROGRAMMING (Using Smartcard Reader / Card)

If the Main Module has been replaced during a repair the board will require programming using the following method.

1. **Do NOT connect the machine to electrical supply.**
2. Insert the pre-programmed card into the Card reader. Care must be taken at this point to ensure the card is inserted correctly with the Chip on the card facing the PCB of the Reader.
3. Insert the Reader and Card into module connection port - see photo.
4. **Connect the machine to the Electrical supply**, the LEDs on the Smart Card Reader will light in this sequence:
 - a) Red ON: Good Communication between Smart Card Reader and Card.
 - b) Red OFF with Green Blinking: Download taking place. Do not unplug the appliance or any connections.
 - c) At end, Green ON ---> Download OK. - Go to 5 below.
 - d) At end, Red ON or RED Flashing ---> Download NOT OK.
5. Programming Complete, disconnect the machine from Electrical supply. Smart will be erased and cannot be used again.
6. Remove the Smart Card Reader.
7. Restart the appliance.

Smart Card Reader and Smart Card in use.

This example shows it connected to a washing machine module connector



See page 14 for connection details.

SMARTCARD PROGRAMMING PROCEDURE - FLOWCHART

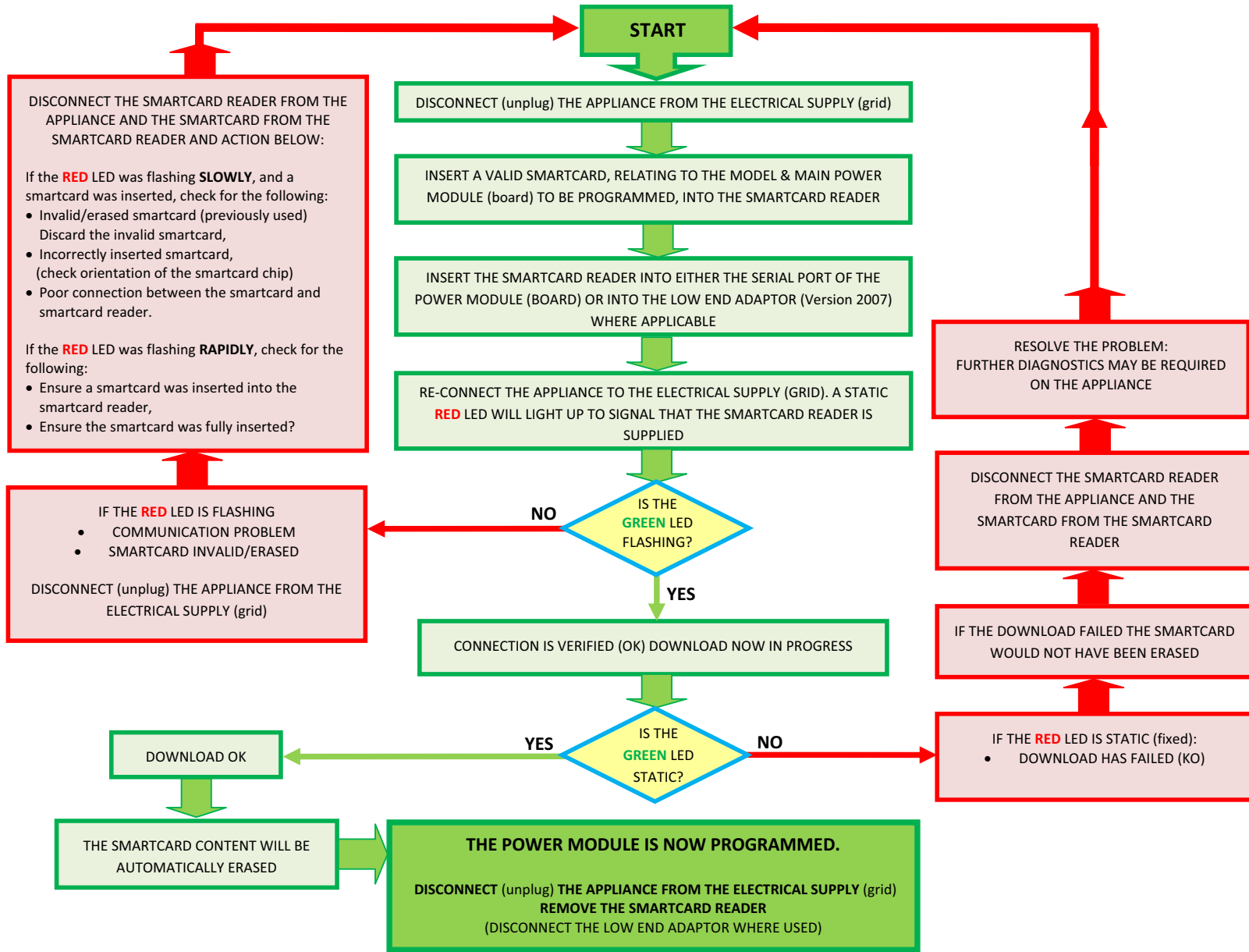

CONNECTING THE LOW END ADAPTOR - 2007 Version with single and twin cable

IMPORTANT:

1. **ALWAYS** unplug the appliance from the mains electricity supply when connecting or disconnecting wiring on the module.
2. **ALWAYS** connect the smart card reader or Hardware Key to the Low End Adaptor **BEFORE** connecting the adaptor to the module PCB connection L4. Ensure correct orientation of the pins.
3. When using the converted Low End Adaptor with the twin cable, **ALWAYS insulate the open end of unused connector block** with PVC tape to prevent it coming into contact with any other items, before connection the mains supply.

The photos below only show the method of connecting the Low End Adaptor (2007) to the module connection L4. These photos do not show the other wiring connections for the appliance. When connecting the low end adaptor to the module in the appliance you should temporarily reassemble the control box and make sure that it is safe before connecting the mains power supply.



Hardware Key Connection

Smartcard Reader Connection

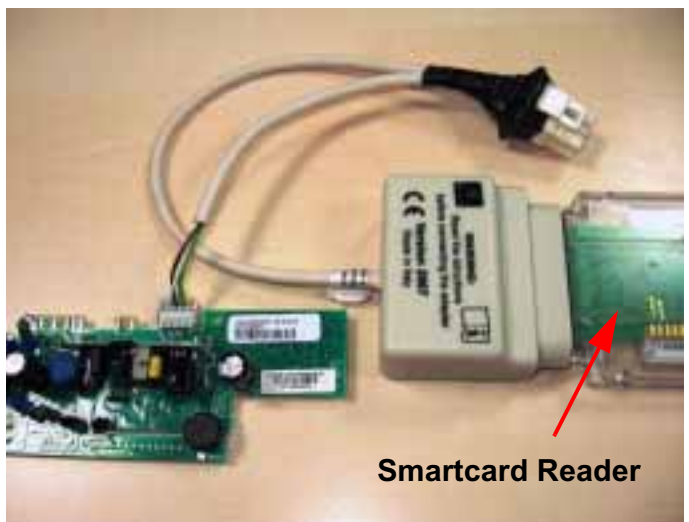
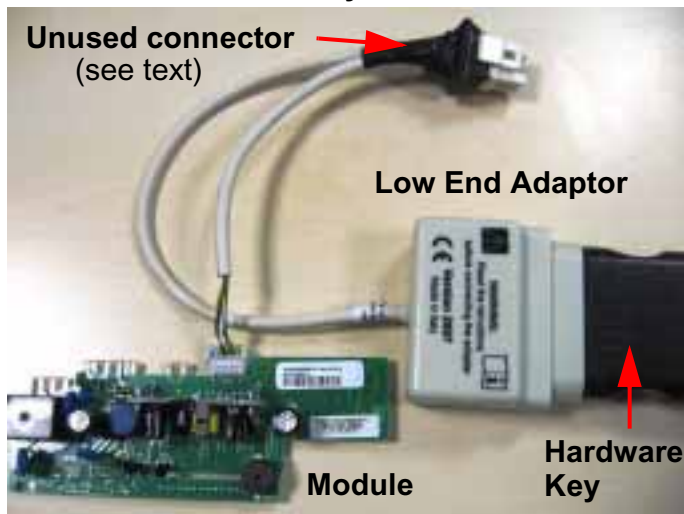

These photos show a 2007 Adaptor which has been converted using C00275571 twin cable.

2007 Adaptors which have not been converted may also be used to program the module.

To avoid damage to the plastic smartcard containing the programming file, insert the smartcard reader into the Low End Adaptor **BEFORE** inserting the smartcard.

Note: Smartcards can only be used ONCE.

Module Light Sequences - shown for illustrative purposes only

**Unprogrammed Module
- with power applied**

Unprogrammed modules will have **all 5 lights illuminated**.

Note:

Service Modules are supplied blank and will require programming. See Programme.

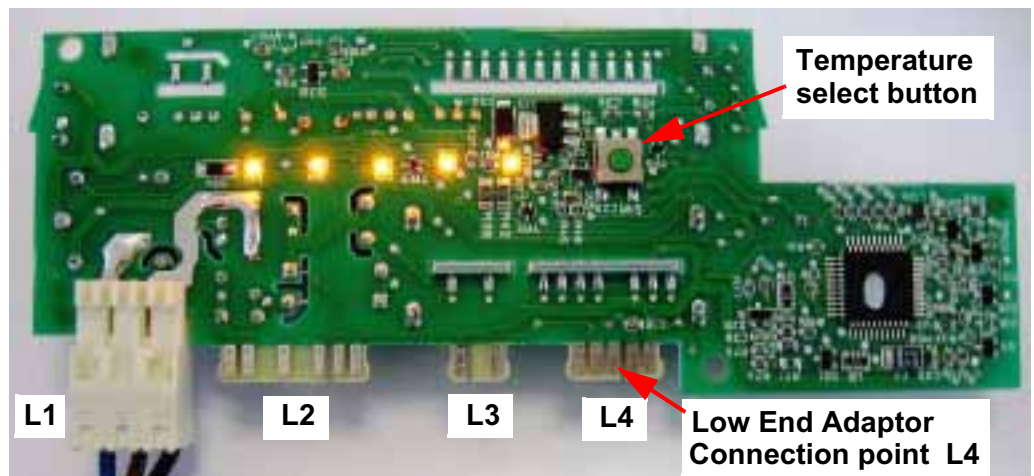

Module - Programmed

Programmed modules will have the **middle light illuminated** by default when powered up after programming.

Note: Pressing the button will step through the LED positions one at a time from right to left then to the off position - indicated by 3 beeps and all lights Off. Further presses will repeat the sequence.



Module - Controls Side

Shown in the Off state - **no lights illuminated**.

The Off state is achieved by stepping through all the temperature options until all lights are Off. The compressor will not run.

An appliance which is disconnected from the main supply will also look like this.



INSTALLATION & DOOR REVERSAL

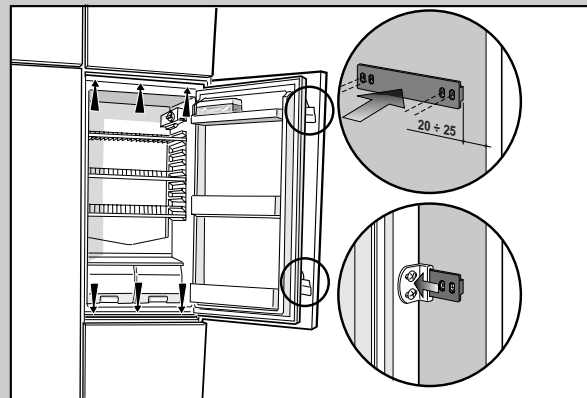
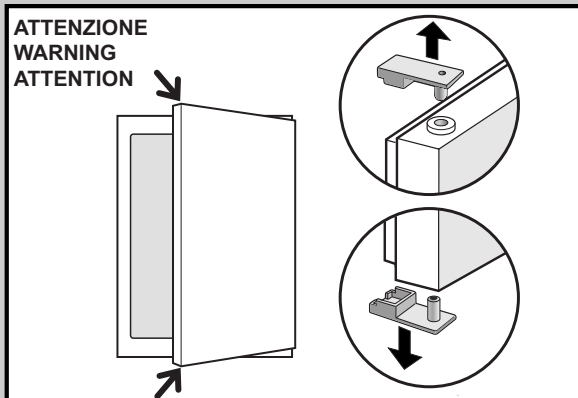
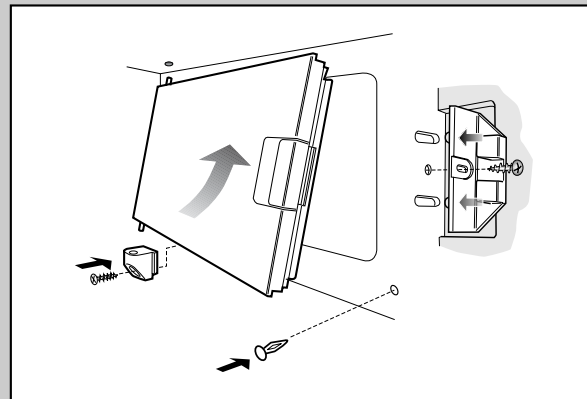
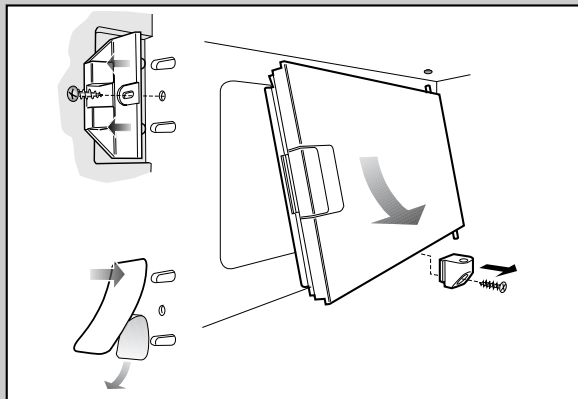
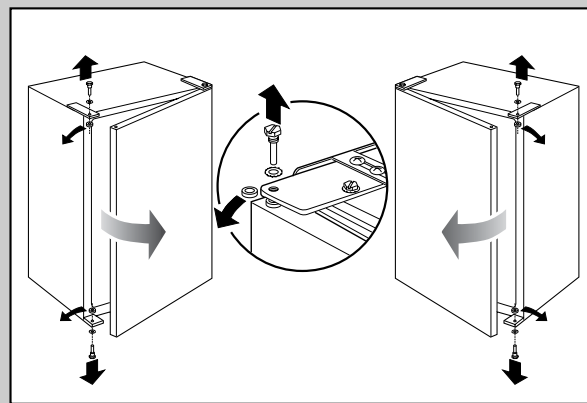
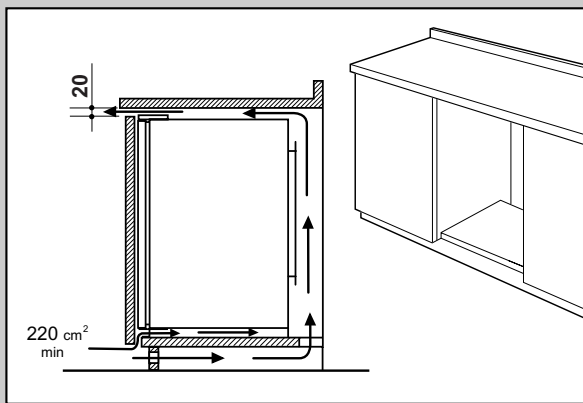
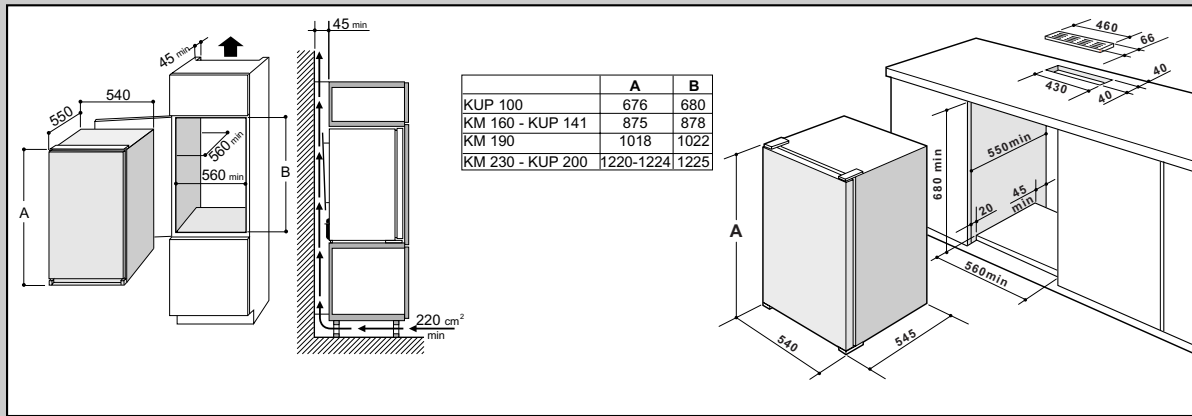

08/2009 - 195021555.07

