



UM9401 / UM9402 / UM9415

COMMERCIAL TWO-WAY RADIO

ANTENNA SWITCH DIODES

DESCRIPTION

Microsemi offers a series of PIN diodes specifically designed and characterized for solid state antenna switches in commercial two-way radios. Antenna switches using the UM9401 and UM9415 series PIN diodes provide high isolation, low loss and low distortion characteristics formerly possible only with electromechanical relay type switches.

The UM9401 and the UM9402 diodes can handle 100 W of transmitter power, while

The UM9415 will handle over 1000 W. The extensive characterization of these PIN diodes in antenna switch applications has resulted in guaranteed low distortion specifications under transmit and receive conditions. These diodes also feature low forward bias resistance and high zero bias impedance which are required for low loss, high isolation and wide bandwidth antenna switch performance.

IMPORTANT: For the most current data, consult MICROSEMI's website: <http://www.microsemi.com>

ABSOLUTE MAXIMUM RATINGS AT 25° C (UNLESS OTHERWISE SPECIFIED)

| Package | Condition | UM9401 | UM9402 | UM9415 |
|---|--|--------|--------|--------|
| Reverse Voltage | @ I _r = 10 uA | 50 V | 50 V | 50 V |
| Average Power Dissipation (P _A) | ½ in. total length to 25 °C Contact 25 °C (Package Flange Temperature Free Air | 5.5 W | 10 W | 10 W |
| | | 1.5 W | | 2.5 W |

KEY FEATURES

- High transmitter power
UM9401/UM9402 => 100 W
UM9415 => 1000 W
- Low harmonic distortion
- Low third order distortion
- High carrier lifetime
- Non cavity design
- Thermally matched configuration
- Low capacitance at 0 V bias
- Low conductance at 0 V bias
- Compatible with automatic insertion equipment

APPLICATIONS/BENEFITS

- Isolated stud package available
- Surface mount package available
-



UM9401 / UM9402 / UM9415

COMMERCIAL TWO-WAY RADIO

ANTENNA SWITCH DIODES

| Parameter | Symbol | Conditions | UM9401/UM9402 | | | UM9415 | | | Units |
|--------------------------------|--------------------------|---|---------------|-----|-----|--------|-----|-----|---------------|
| | | | Min | Typ | Max | Min | Typ | Max | |
| Reverse Current | I_R | $V_r = 50\text{ V}$ | 10 | | | 10 | | | μA |
| Series Resistance | R_S | $I_f = 50\text{ mA}$, $F = 100\text{ MHz}$ | 1.0 | | | 1.0 | | | Ohm |
| Capacitance | C_T | $V_R = 0\text{ V}$, $F = 100\text{ MHz}$ | 1.5 | | | 4 | | | pF |
| Parallel Resistance | R_P | $V_R = 0\text{ V}$, $F = 100\text{ MHz}$ | 5k | | | 1k | | | Ohms |
| Carrier Lifetime | τ | $I_F = 10\text{ mA}$ | 2.0 | | | 5.0 | | | us |
| Forward Voltage | V_f | $I_f = 50\text{ mA}$ | 1.0 | | | 1.0 | | | V |
| Transmit Harmonic Distortion | $R_{2A/A}$ $R_{3A/A}$ | $P_{in} = 50\text{ W}$ $f = 50\text{ MHz}$, $I_f = 50\text{ mA}$ | 80 | | | 80 | | | -dB |
| Receive Third Order Distortion | $R_{2AB/A}$ | $P_{in} = 10\text{ W}$, 0 V Bias $f_A = 50\text{ MHz}$, $f_B = 51\text{ MHz}$ | 60 | | | 60 | | | -dB |

Rs versus If
TYPICAL

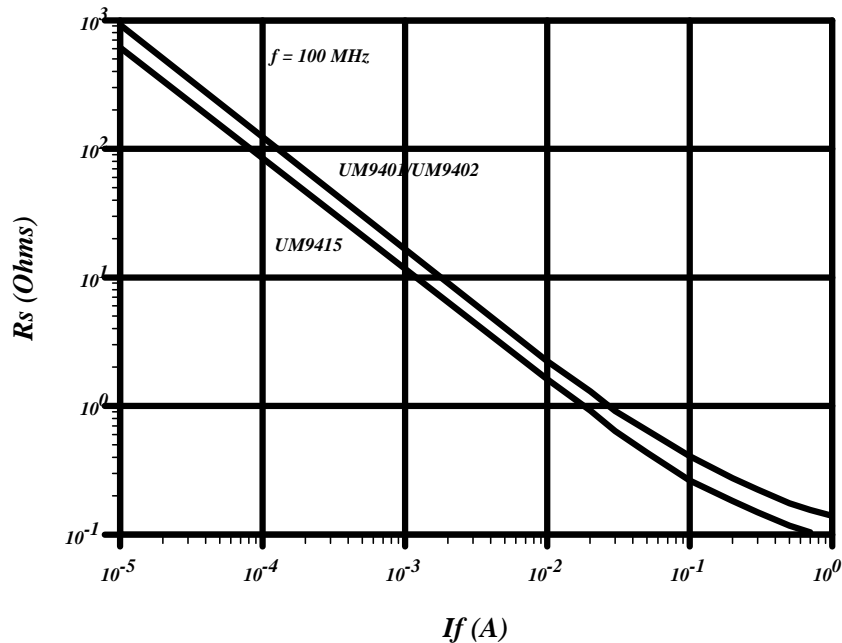

C_t versus f
TYPICAL

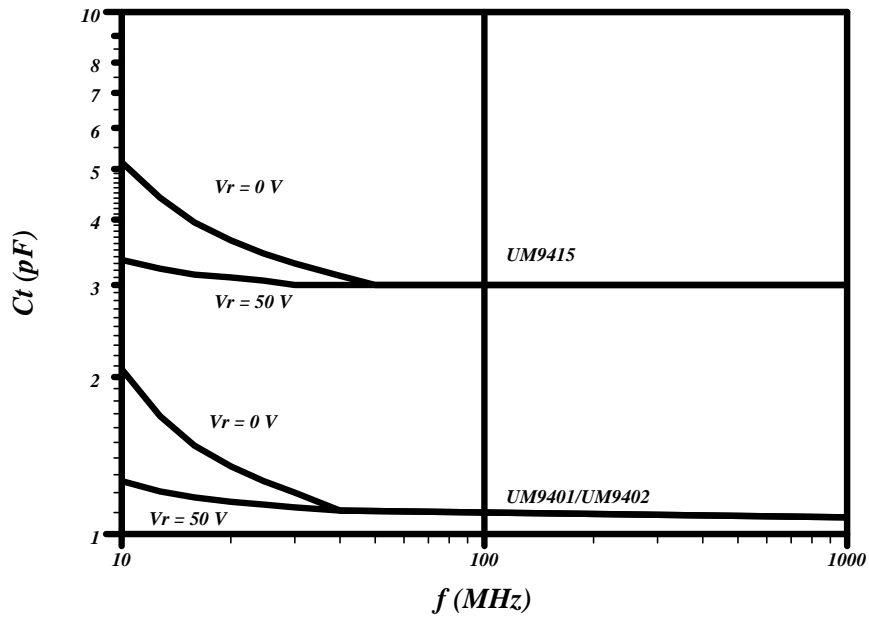

V_f versus I_f
TYPICAL

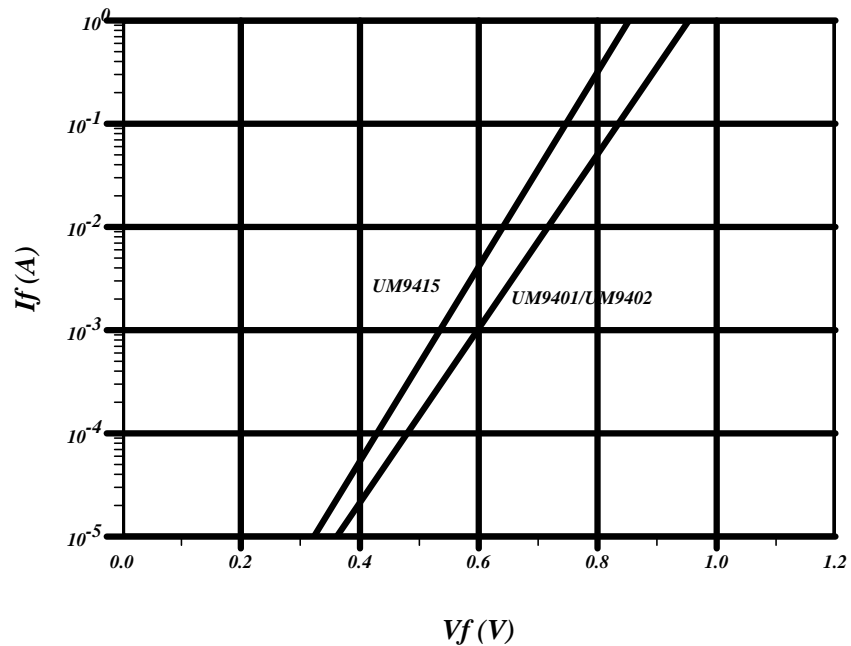

R_p versus f
TYPICAL

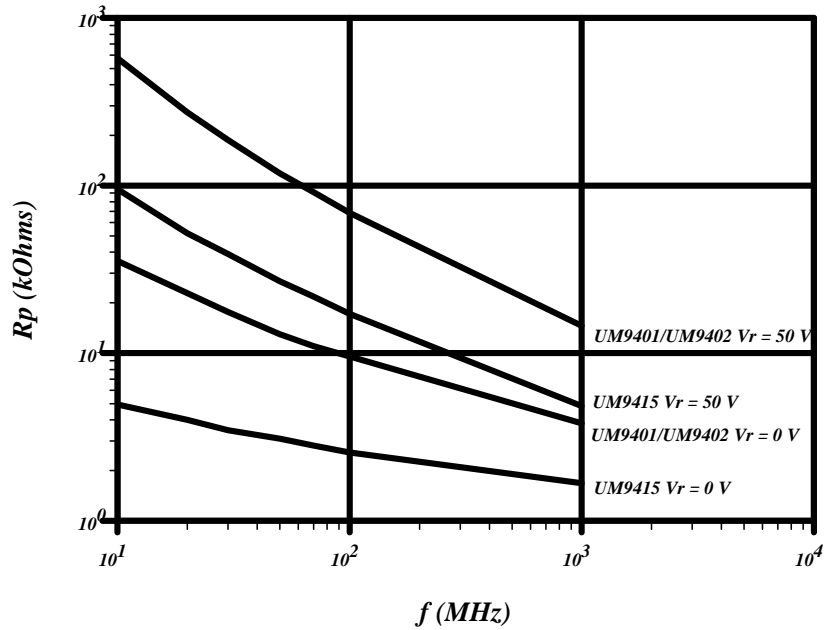

POWER RATING
UM9415

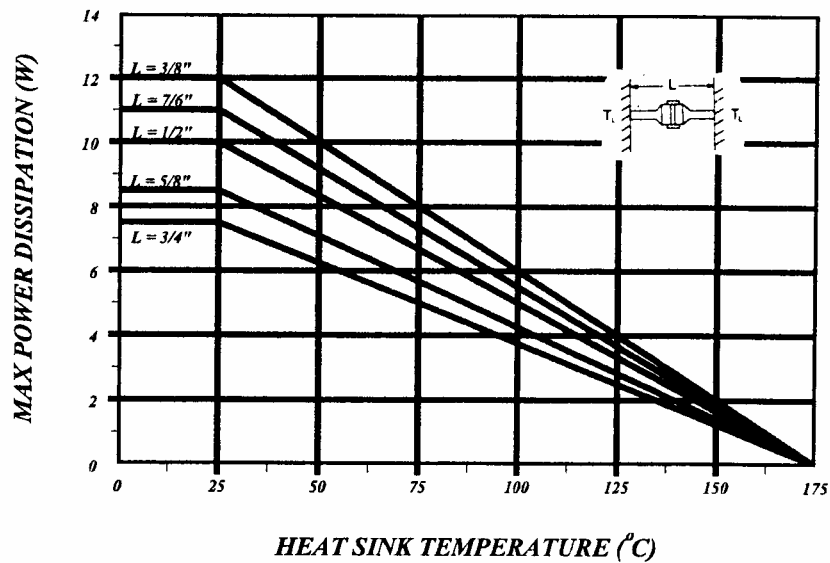

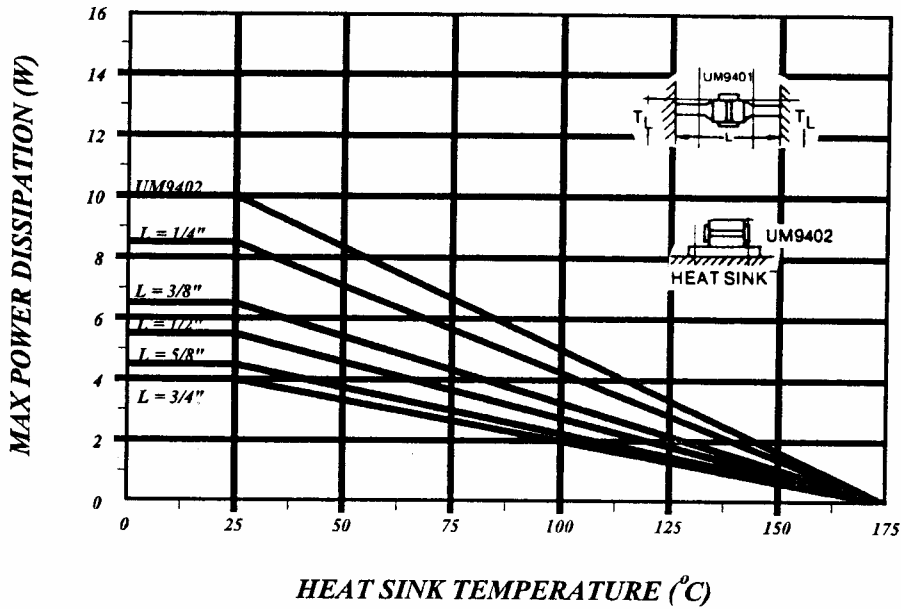
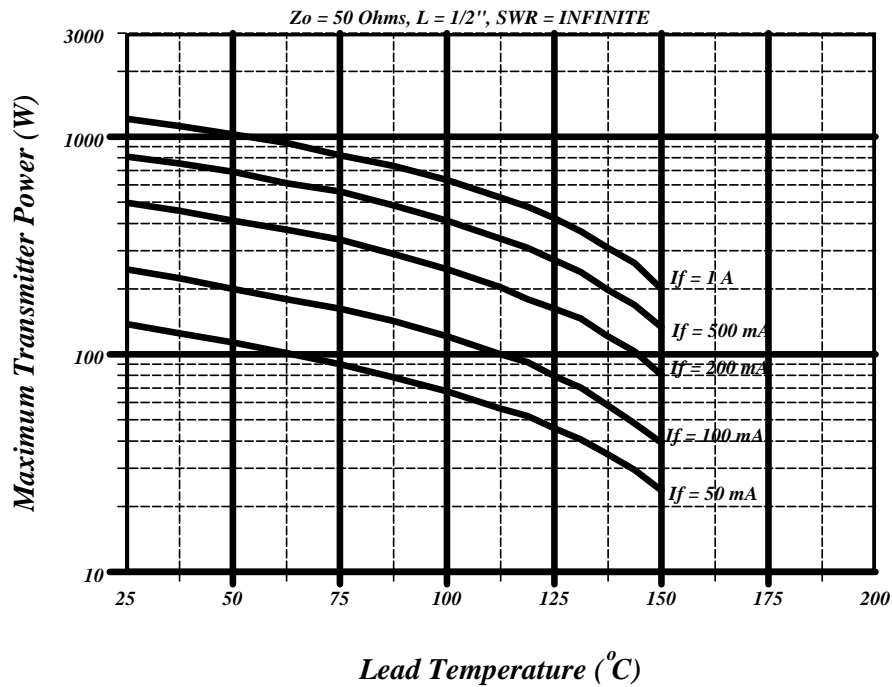
**POWER RATING
UM9401/UM9402**

**MAXIMUM TRANSMITTER POWER
UM9415**



UM9401 / UM9402 / UM9415

COMMERCIAL TWO-WAY RADIO

ANTENNA SWITCH DIODES

MAXIMUM TRANSMITTER POWER UM9401/UM9402

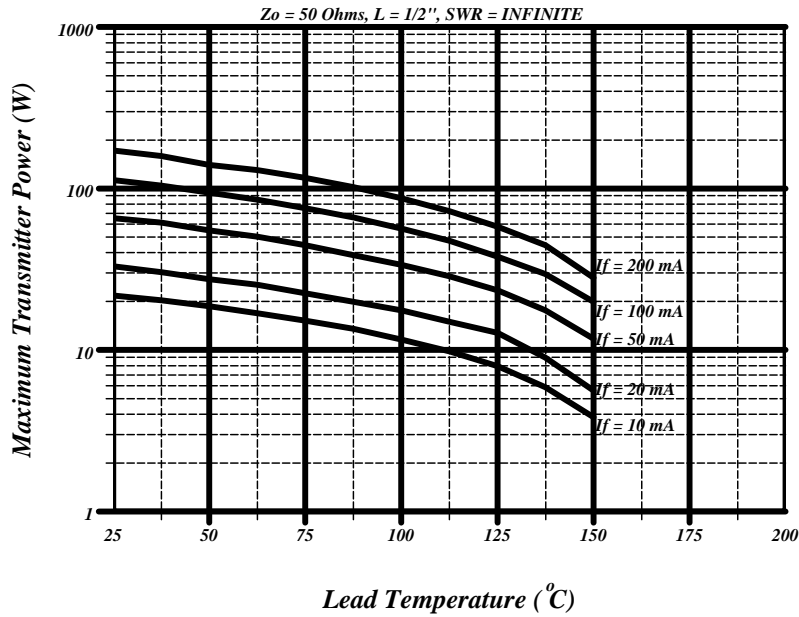

Maximum Transmitter Power

The maximum CW transmitter power, $P_{T(max)}$, a PIN diode antenna switch can handle depends on the diode resistance, R_S , power dissipation, P_D , antennae SWR, σ , and the nominal impedance, Z_0 . The expression is as follows:

is less than 0.3 dB. This performance is achievable across a $\pm 20\%$ bandwidth at center frequencies ranging from 10 to 500 MHz.

Characteristic curves are shown in the data section which gives both the maximum and typical diode resistance, R_S as a function of forward current. The maximum power dissipation rating of the PIN diode depends both on the length of the diode leads and the temperature of the contacts to which the leads are connected. A graph defining the maximum power dissipation at various combinations of overall lead length (L) and lead temperature (T_L) is given in the data section. From these curves and the above equation, the power handling capability of the PIN diode may be computed for a specific application.

Curves are also presented which show the maximum transmitter power that an antenna switch using UM9401s and UM9415s can safely handle for various forward currents and lead temperatures. These curves are based on a typical design condition of a $\frac{1}{2}$ in. total overall lead length, $50\ \Omega$ line impedance, and a totally mismatched antenna ($\sigma = \infty$). For the case of a perfectly matched antenna, the maximum transmitter power can be increased by a factor of 4.

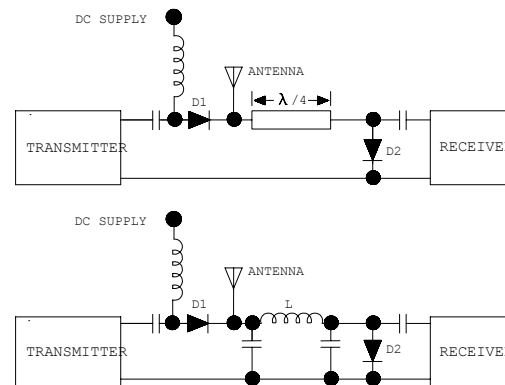

$$L = Z_0 / 2 \pi f_0 \quad (H)$$

$$C = 1/2 \pi f_0 Z_0 \quad (F)$$

Design Information

A circuit configuration for a two-way radio antenna switch using PIN diodes consists of a diode placed in series with the transmitter and a shunt diode placed a quarter wavelength from the antenna in the direction of the receiver as shown. For low frequency operation, the quarter wave line may be simulated by lumped elements. Typical performance of antenna switches using PIN diodes forward biased at 100 mA is less than 0.2 dB insertion loss and 30 dB isolation during transmit; at zero bias the receive insertion loss

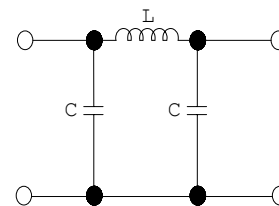

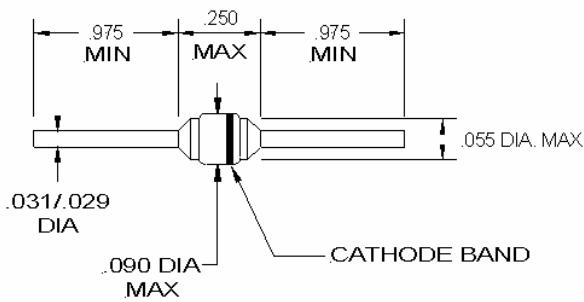
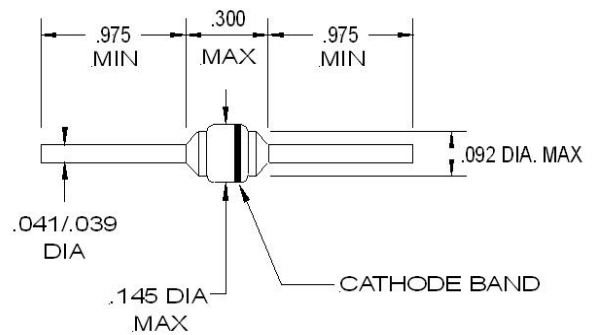
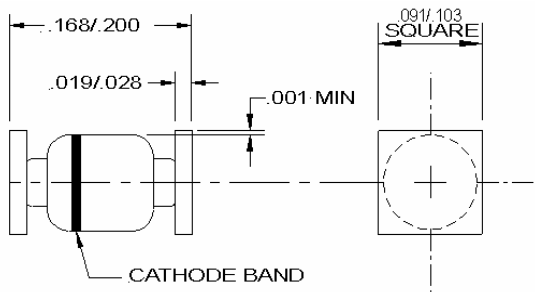
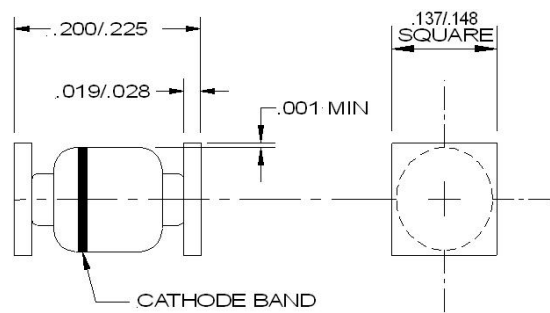
STYLE "UM9401B"

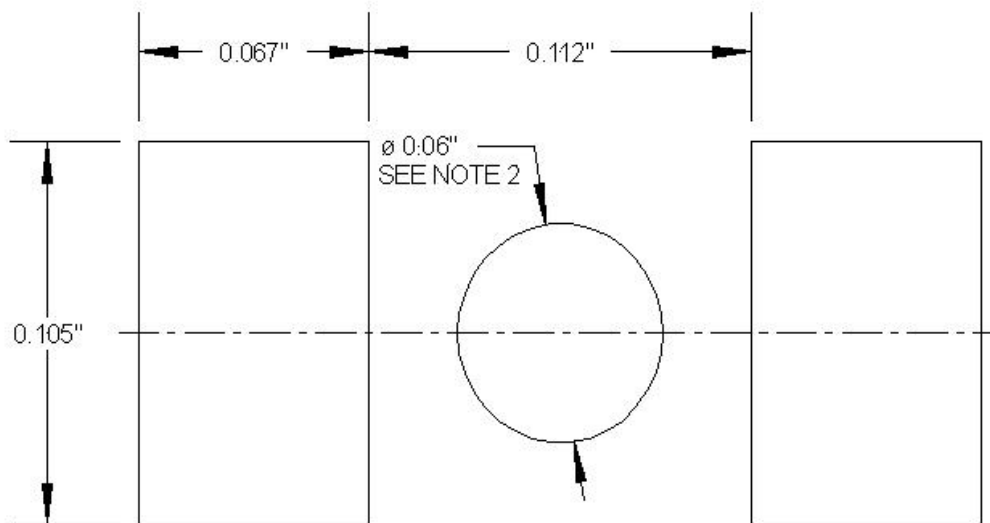
STYLE "UM9415B"

STYLE "UM9401SM"

STYLE "UM9415SM"

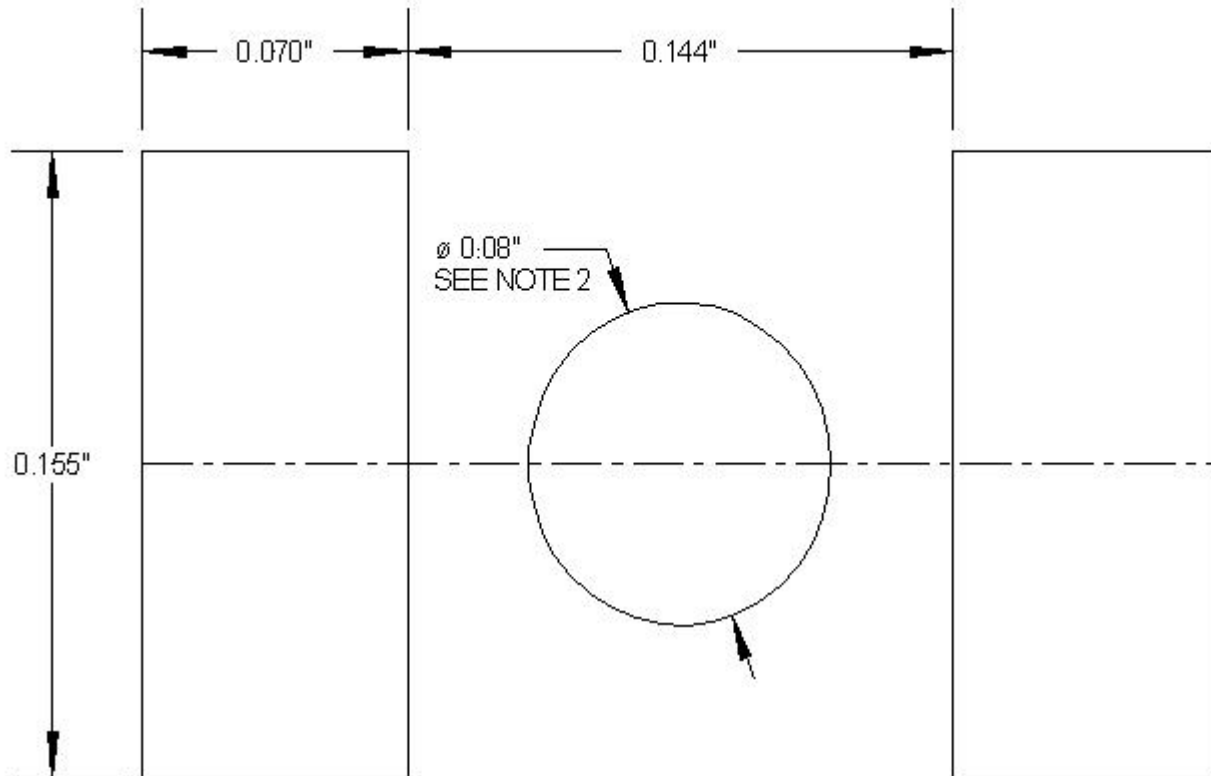
UM9401 STYLE "SM" FOOTPRINT**A SIZE
(STANDARD SMALL
SQUARE END CAP OUTLINE)****NOTES:**

1. These dimensions will match the terminals and provide for additional solder fillets at the outboard ends at least as wide as the terminals themselves, assuming accuracy of placement within 0.005"
2. If the mounting method chosen requires use of an adhesive separate from the solder compound, a round (or square) spot of cement as shown should be centrally located.

UM9415 STYLE "SM" FOOTPRINT



B SIZE
(STANDARD LARGE
SQUARE END CAP OUTLINE)

NOTES:

- 1: THESE DIMENSIONS WILL MATCH THE TERMINALS AND PROVIDE FOR ADDITIONAL SOLDER FILLETS AT THE OUTBOARD ENDS AT LEAST AS WIDE AS THE TERMINALS THEMSELVES, ASSUMING ACCURACY OF DEVICE PLACEMENT WITHIN 0.005".
- 2: IF THE MOUNTING METHOD CHOSEN REQUIRES USE OF AN ADHESIVE SEPARATE FROM THE SOLDER COMPOUND, A ROUND (OR SQUARE) SPOT OF CEMENT AS SHOWN SHOULD BE CENTRALLY LOCATED.



UM9401 / UM9402 / UM9415

COMMERCIAL TWO-WAY RADIO

ANTENNA SWITCH DIODES

NOTES: