

RF AND MICROWAVE DEVICES SYSTEM BLOCK DIAGRAMS

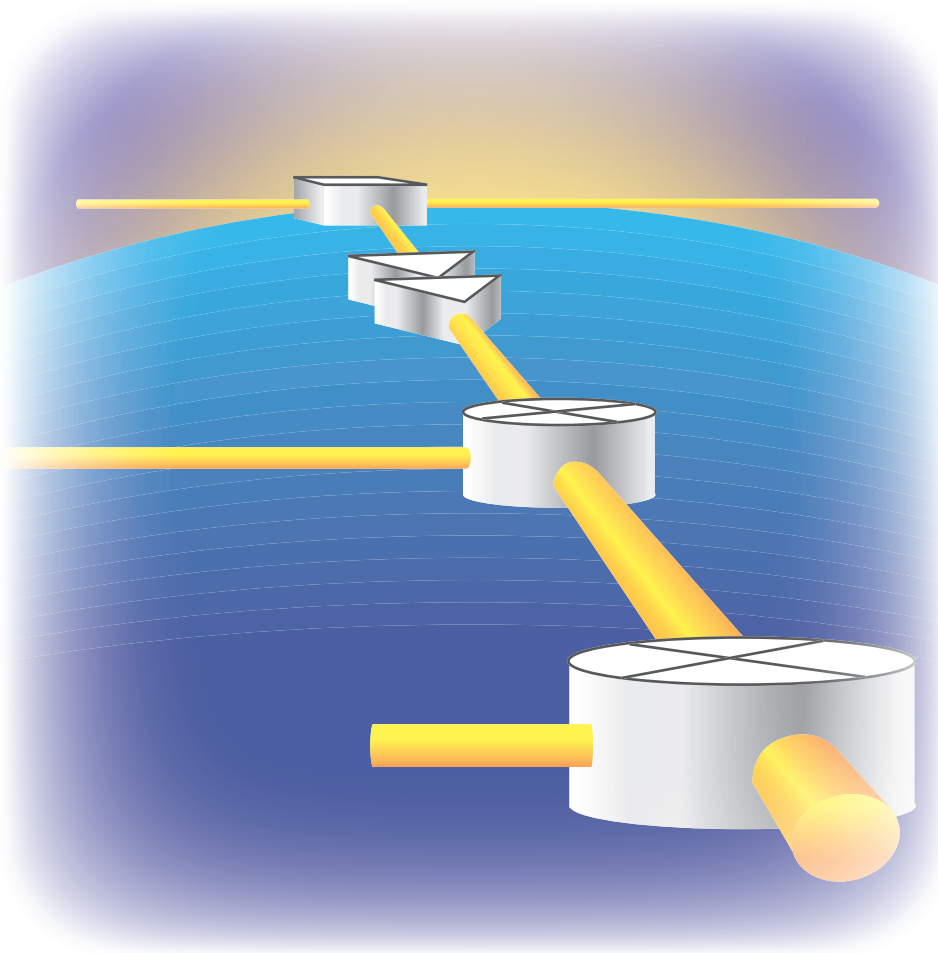

CONTENTS

1. INTRODUCTION	3
1-1. Basic RF Blocks	4
2. EXPLANATION OF THE RF AND MICROWAVE DEVICES	5
2-1. Mobile Communication System	5
<R> Digital Cellular Phone	5
<R> W-CDMA	7
<R> N-CDMA	9
<R> PHS (Digital Cordless Phone)	11
<R> DECT (Digital Cordless Phone)	13
<R> CT-2 (Digital Cordless Phone)	14
<R> GSM (Digital Cellular Phone)	15
5.8 GHz Digital Cordless Phone	17
<R> 900 MHz Cordless Phone (Analog Cordless Phone)	18
2-2. Multimedia System	20
<R> Digital TV Tuner / Digital CATV Set-top-box	20
Digital DBS (Satellite Broadcasting)	22
<R> Cable Modem	24
2-3. Others	26
GPS.....	26
FRS (Family Radio Service) / GMRS (General Mobile Radio Service)	28
Bluetooth	30
<R> 2.4 GHz Wireless LAN	32
5 GHz Wireless LAN	34
2.4 GHz & 5 GHz Dualband Wireless LAN	36
N-CDMA, GSM Cellular Phone Base Station (900 MHz Band)	37
<R> W-CDMA Cellular Phone Base Station	38
<R> 3. WEB SITE INFORMATION	39
Revisions History	40

1. INTRODUCTION

The Microwave Devices are used for each system as shown in Figure 1. This catalog explains the Microwave devices by each Microwave block diagram for the application system.

The basic block diagram is indicated to Figure 2.

Figure 1 Example of the Microwave application systems

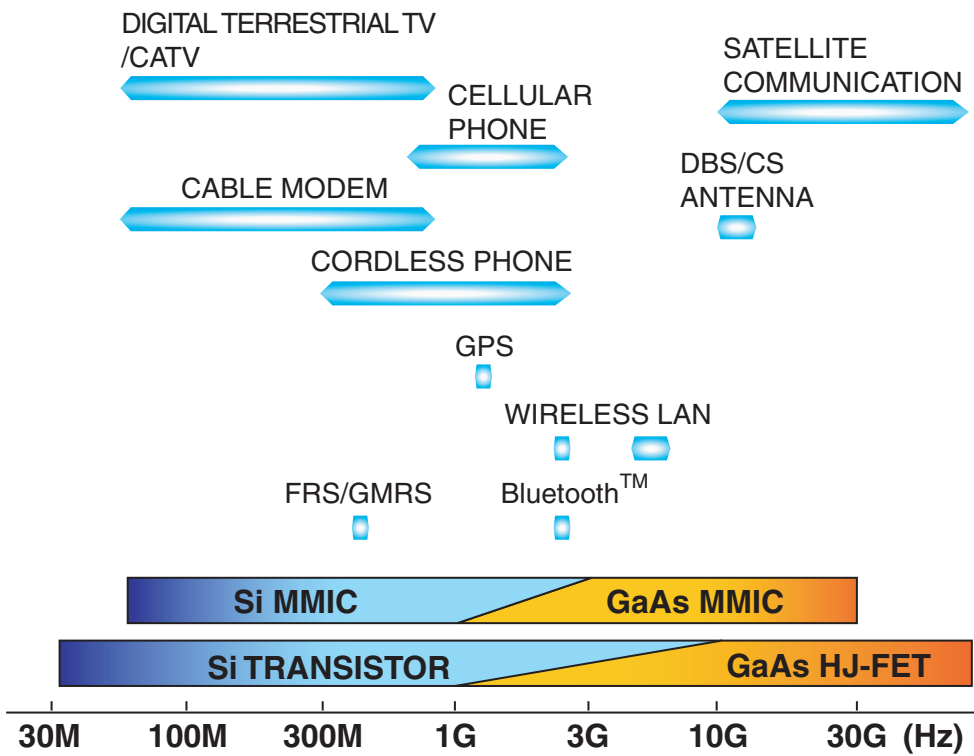

The mark <R> shows major revised points.

The revised points can be easily searched by copying an "<R>" in the PDF file and specifying it in the "Find what:" field.

1-1. Basic RF Blocks

The basic RF block consists of nine function blocks as shown in the next figure.

Figure 2 Microwave Basic Blocks

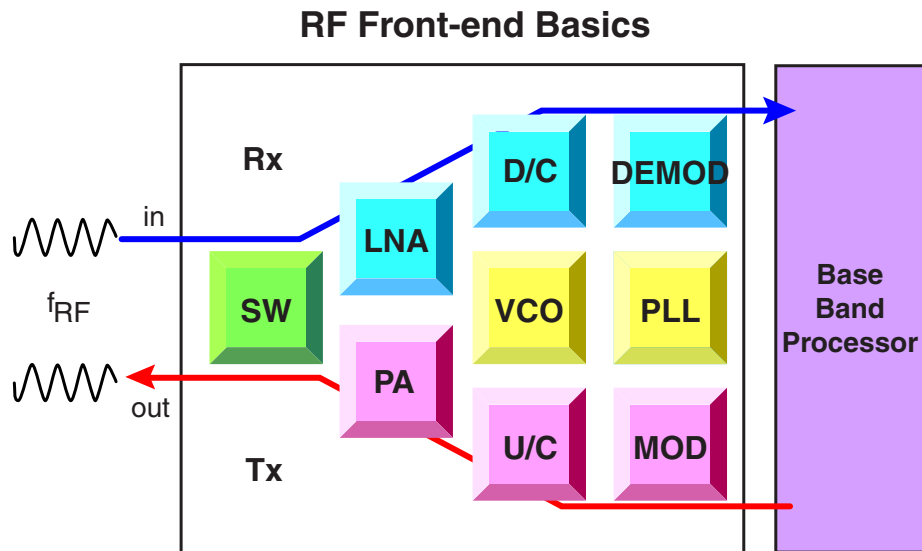

1. SW (Switch)
2. LNA (Low Noise Amplifier)
3. PA (Power Amplifier)
4. D/C (Down-converter)
5. VCO (Voltage Controlled Oscillator)
6. U/C (Up-converter)
7. DEMOD (Demodulator)
8. PLL (Phase Locked Loop)
9. MOD (Modulator)

The application circuits and their parameters are for reference only and are not intended for use in actual design-ins.

2. EXPLANATION OF THE RF AND MICROWAVE DEVICES

Explain the devices by the microwave block diagram for following application systems.

2-1. Mobile Communication System Digital Cellular Phone

RF Front-end Basics

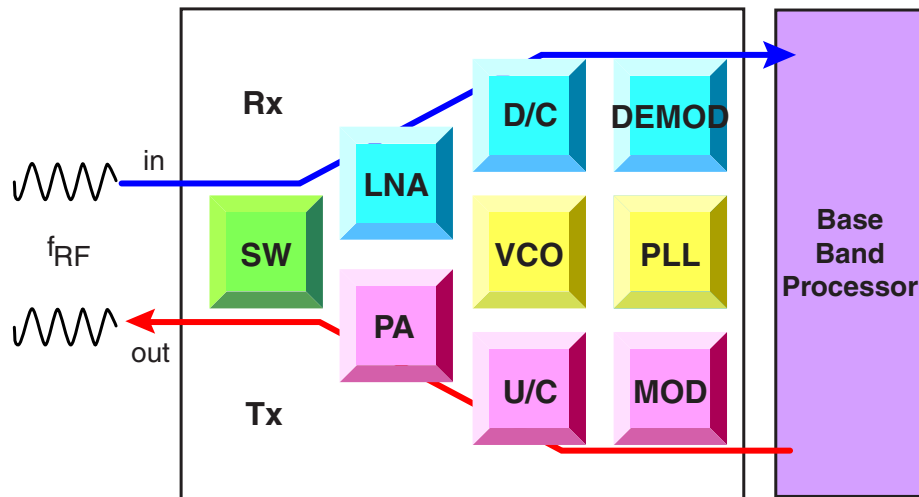

Recommended device list

Block	Function	Type Name	Feature
LNA	Discrete Tr.	2SC5015(NE68518)	Si Bipolar Tr. ($f_T = 12$ GHz)
		2SC5185(NE68718) etc.	Si Bipolar Tr. ($f_T = 15.5$ GHz)
		2SC5369(NE696M01)	Si Bipolar Tr. ($f_T = 14$ GHz)
D/C	Down-converter	μ PC8112TB	6-pin Super Minimold
DEMOD	2nd Mixer + RSSI	-	-
PLL	Dual PLL	-	-
VCO	Oscillator + Buffer	μ PA8xx Series	Twin Tr.
	Buffer	μ PC8128TB μ PC8178TB/TK	Low Current Consumption
U/C + MOD	I/Q Modulator	-	-
SW	SPDT SW	μ PG2009TB	GaAs SW IC, 6-pin Super Minimold
		μ PG2010TB	

<R>

Remark The devices listed in the above table are merely examples. The product recommendation may change depending on the requirements of each system's design.

System configuration example 1
Digital Cellular Phone
(RF Modulation System)

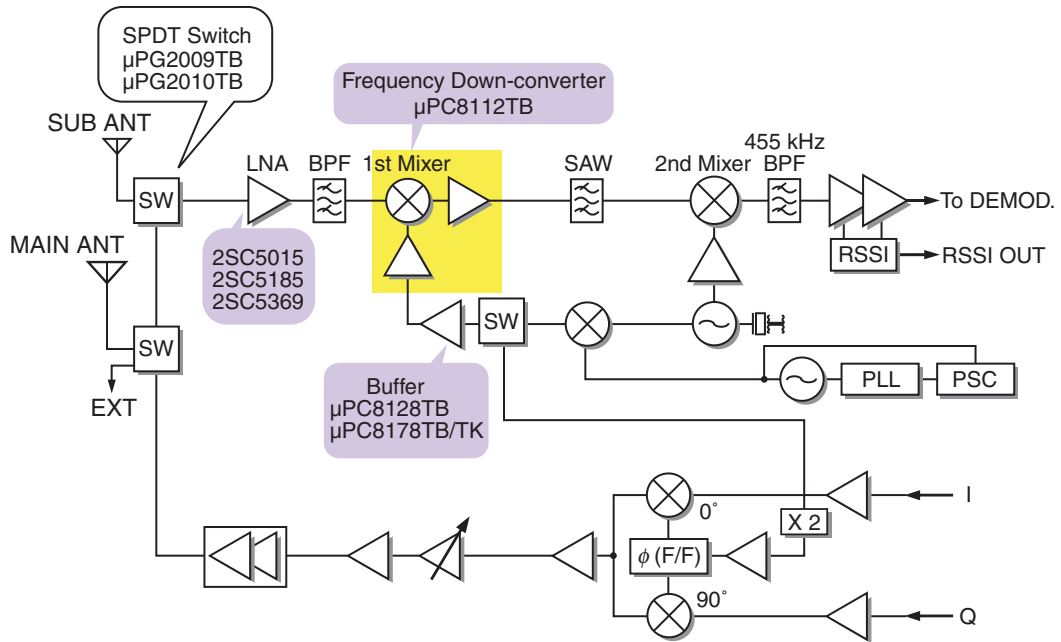

System configuration example 2
Digital Cellular Phone
(IF Modulation System)

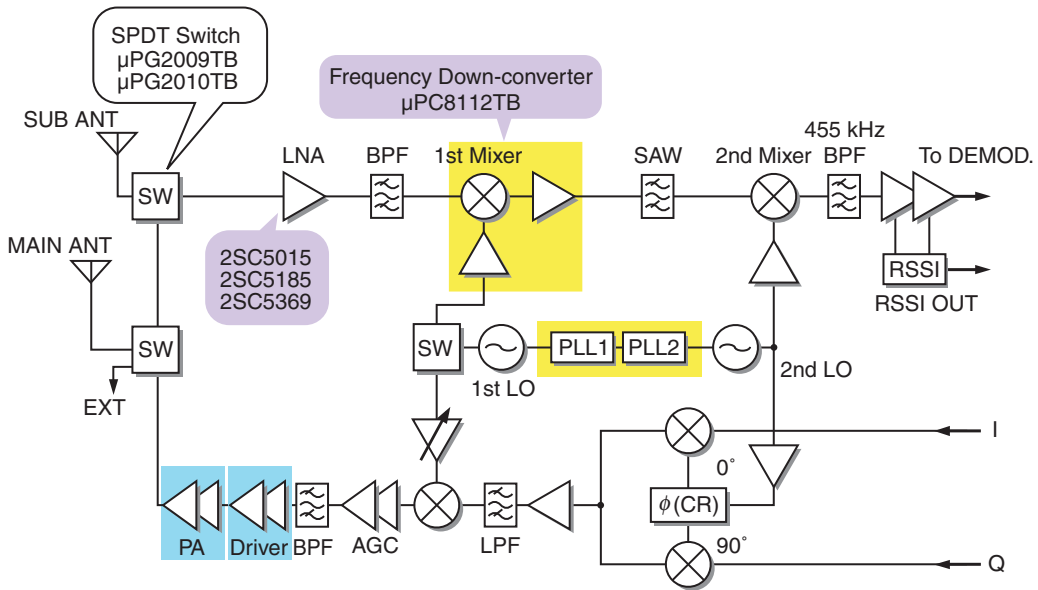

W-CDMA

RF Front-end Basics

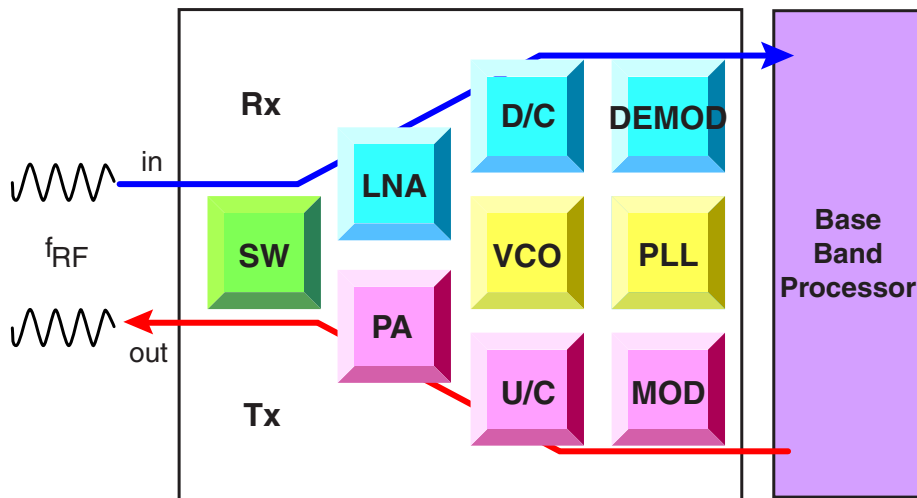

Recommended device list

Block	Function	Type Name	Feature
LNA	Discrete Tr.	2SC5508(NE662M04)	Si Bipolar Tr. ($f_T = 25$ GHz)
		2SC5761(NESG2030M04)	SiGe HBT
		NESG2031M05	
		NESG2031M16	
D/C	Down-converter	-	-
DEMOD	IF AGC + I/Q Demodulator	-	-
PLL	Dual PLL	-	-
VCO	Oscillator + Buffer	μ PA8xx Series	Twin Tr.
	Buffer	μ PC8179TB μ PC8179TK	-
U/C	Up-converter	μ PC8172TB μ PC8187TB	6-pin Super Minimold
		μ PC8172TK	6-pin Lead-less Minimold (1511)
		-	-
MOD	IF AGC + I/Q Modulator	-	-
SW	SPDT SW	μ PG2009TB, μ PG2010TB	GaAs SW IC, 6-pin Super Minimold

<R>

Remark The devices listed in the above table are merely examples. The product recommendation may change depending on the requirements of each system's design.

System configuration example W-CDMA transceiver

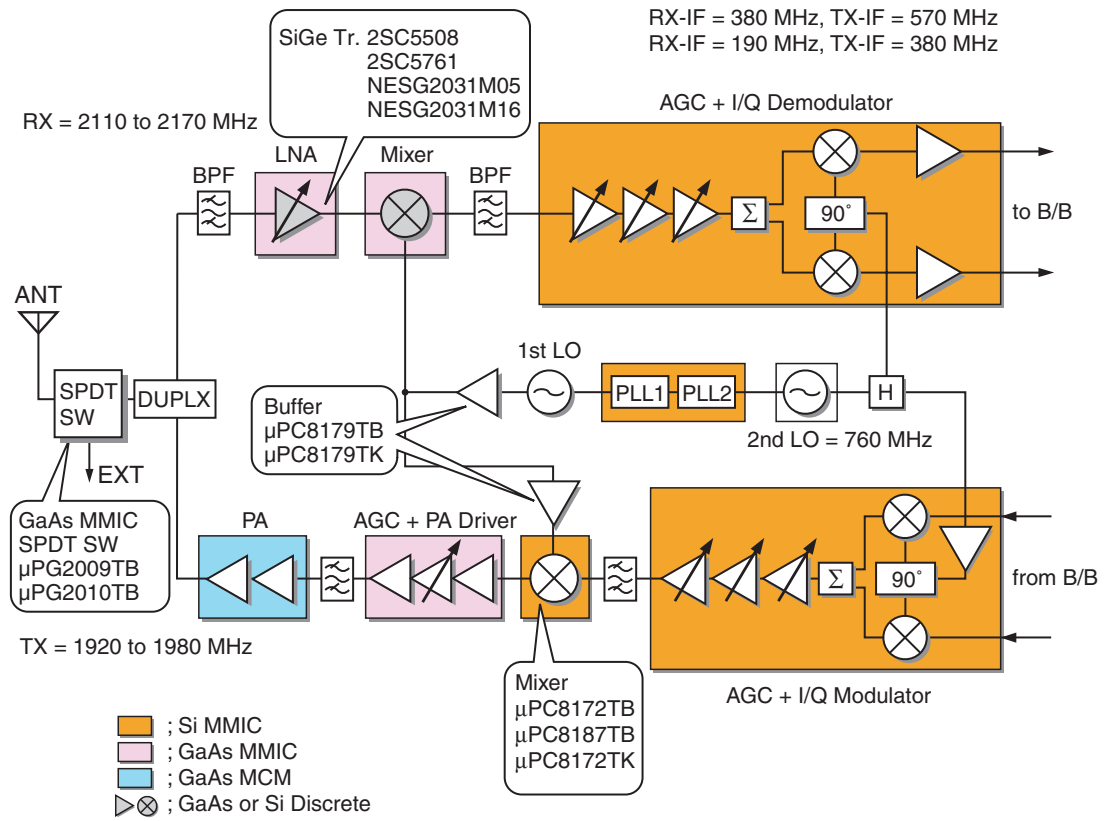

N-CDMA

RF Front-end Basics

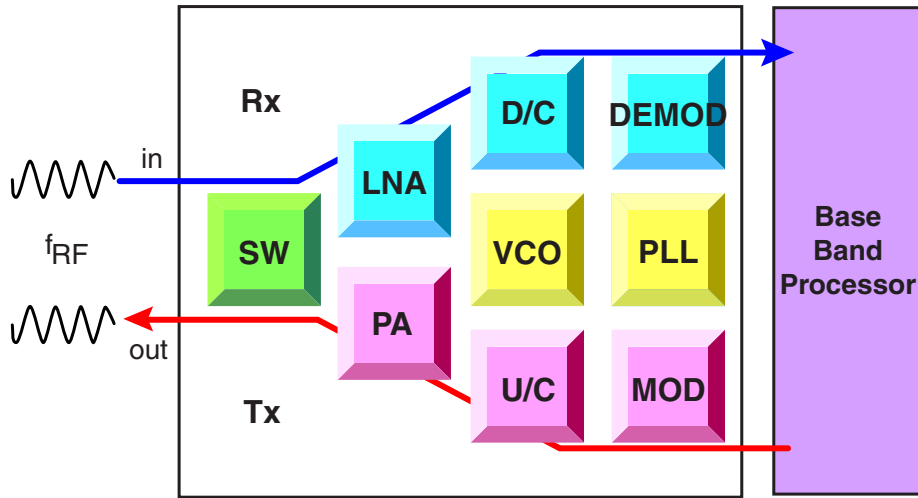

Recommended device list

<R>

Block	Function	Type Name	Feature
LNA	Discrete Tr.	2SC5508(NE662M04)	Si Bipolar Tr. ($f_T = 25$ GHz)
D/C	Down-converter	-	-
DEMOD	IF AGC + I/Q Demodulator	-	-
PLL	Dual PLL	-	-
VCO	Oscillator + Buffer	μ PA8xx Series	Twin Tr.
	Buffer	μ PC8128TB μ PC8151TB μ PC8178TB/TK μ PC8179TB/TK	-
U/C + MOD	Up-converter	μ PC8172TB μ PC8187TB	6-pin Super Minimold
		μ PC8172TK	6-pin Lead-less Minimold (1511)
PA	-	-	-
SW	SPDT SW	μ PG2009TB μ PG2010TB	GaAs SW IC
	SP3T SW	μ PG2031TQ μ PG2404T6Q	GaAs SW IC

Remark The devices listed in the above table are merely examples. The product recommendation may change depending on the requirements of each system's design.

System configuration example N-CDMA transceiver

Li-ion Battery Pack 1cell: 3.6 V(TYP.)

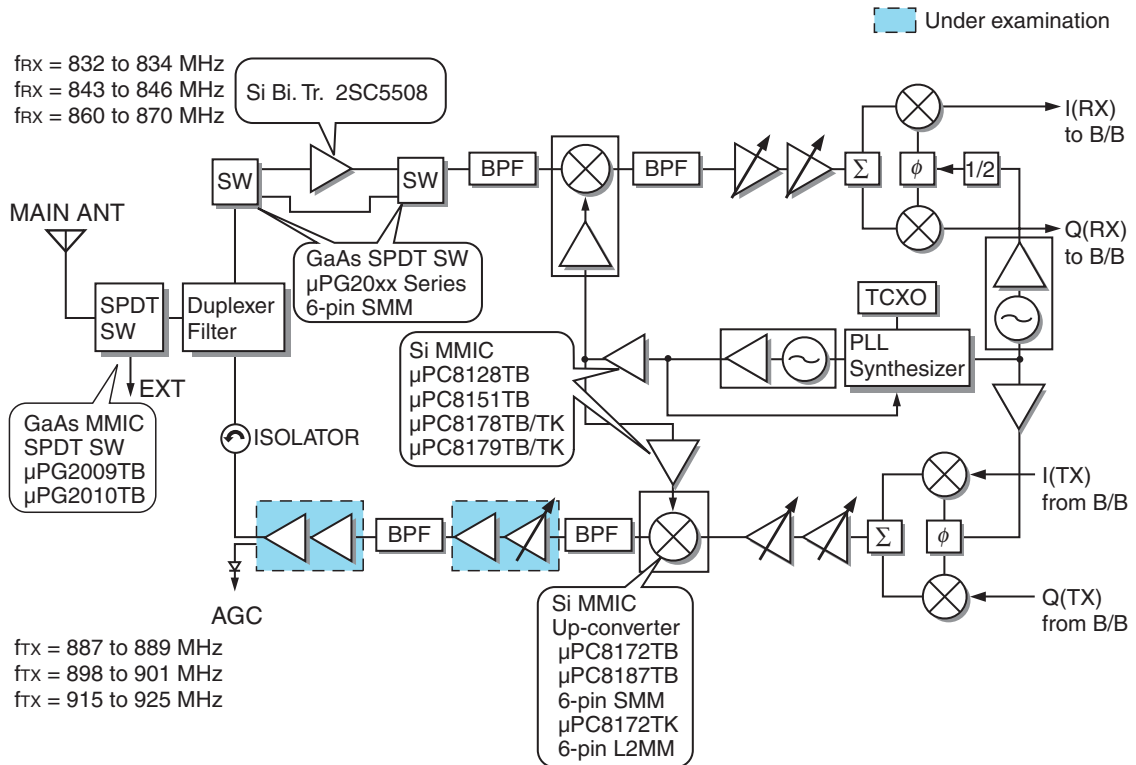

PHS (Digital Cordless Phone)

RF Front-end Basics

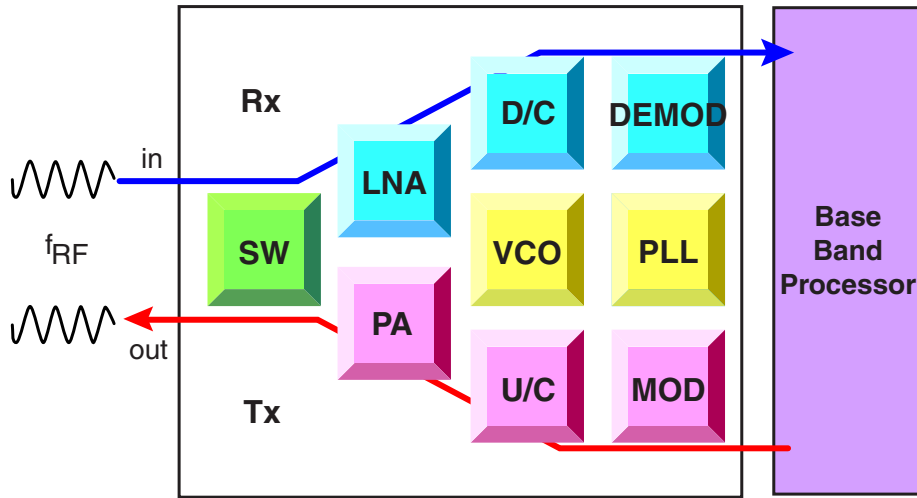

<R>

Recommended device list

Block	Function	Type Name	Feature
LNA	SiGe HBT	NESG2031M05/M16	High Gain, Low Noise
D/C	Down-converter	μ PC8112TB	6-pin Super Minimold
LNA + D/C	LNA + Down-converter	-	-
DEMOD	IF D/C + RSSI	-	-
PLL	Dual PLL Synthesizer	-	-
VCO	Oscillator + Buffer	μ PA8xx Series	Twin Tr.
MOD + U/C	I/Q Modulator + Up-converter	-	-
U/C	Up-converter	μ PC8106TB	6-pin Super Minimold
PA	Discrete Tr.	2SC5288(NE68939) 2SC5289(NE69039) 2SC5754(NE644M04)	Medium Output Power Use Tr.
SW	SPDT SW	μ PG2015TB μ PG2030TK μ PG2406T6R	GaAs SW IC, 6-pin Super Minimold GaAs SW IC, 6-pin Lead-less Minimold (1511) GaAs SW IC, 6-pin TSSON (1010)

Remark The devices listed in the above table are merely examples. The product recommendation may change depending on the requirements of each system's design.

**System configuration example
PHS (Digital Cordless Phone)**

<R>

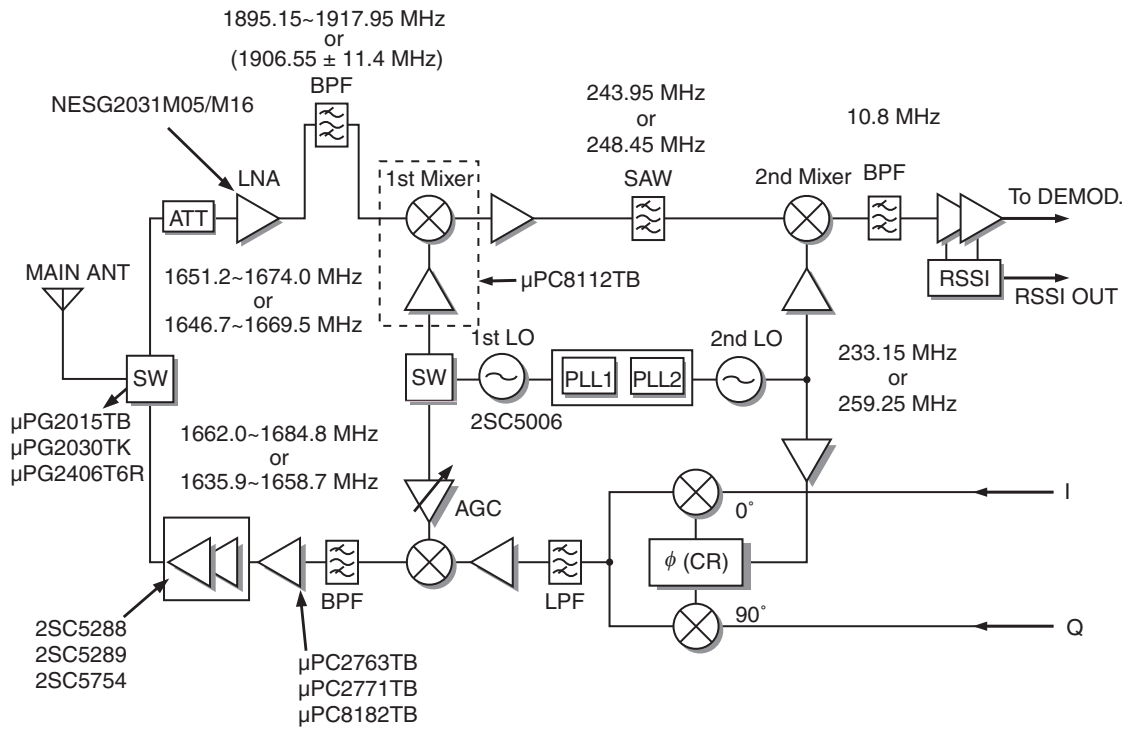

DECT (Digital Cordless Phone)

RF Front-end Basics

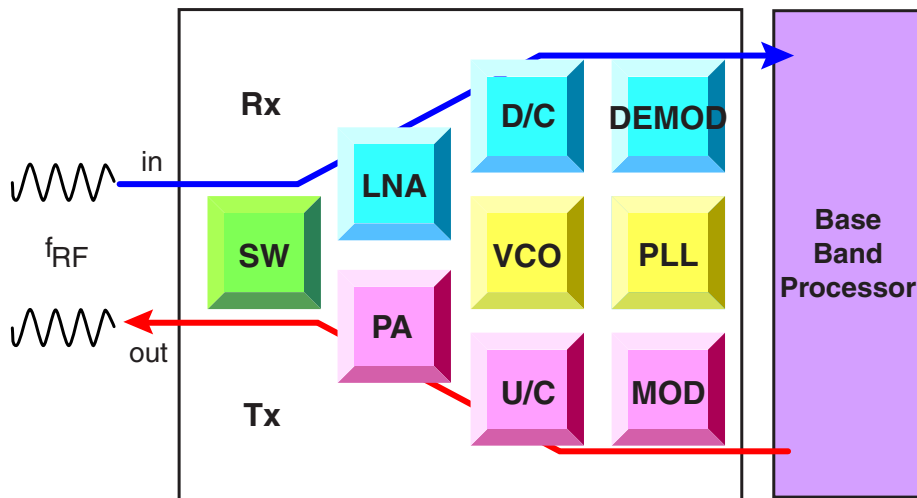

<R>

Recommended device list

Block	Function	Type Name	Feature
LNA	Discrete Tr.	2SC5369(NE696M01)	High fr, Low Noise
	HJ-FET	NE3509M04	Low Noise GaAs FET
D/C	Down-converter	μ PC2756TB	6-pin Super Minimold
		μ PC2757TB	
		μ PC2758TB	
		μ PC8112TB	
DEMOD	IF D/C + RSSI	-	-
PLL	Dual PLL Synthesizer	-	-
VCO	Oscillator + Buffer	μ PA8xx Series	Twin Tr.
MOD (OSC)	Oscillator + Buffer	μ PA8xx Series	Twin Tr.
U/C	Up-converter	μ PC8106TB	6-pin Super Minimold
PA	Discrete Tr.	2SC5288(NE68939)	Medium Output Power Use Tr.
		2SC5289(NE69039)	
		2SC5754(NE664M04)	
SW	SPDT SW	μ PG2179TB	GaAs SW IC, 6-pin Super Minimold
		μ PG2030TK	GaAs SW IC, 6-pin Lead-less Minimold (1511)
		μ PG2406T6R	GaAs SW IC, 6-pin TSSON (1010)

Remark The devices listed in the above table are merely examples. The product recommendation may change depending on the requirements of each system's design.

CT-2 (Digital Cordless Phone)

RF Front-end Basics

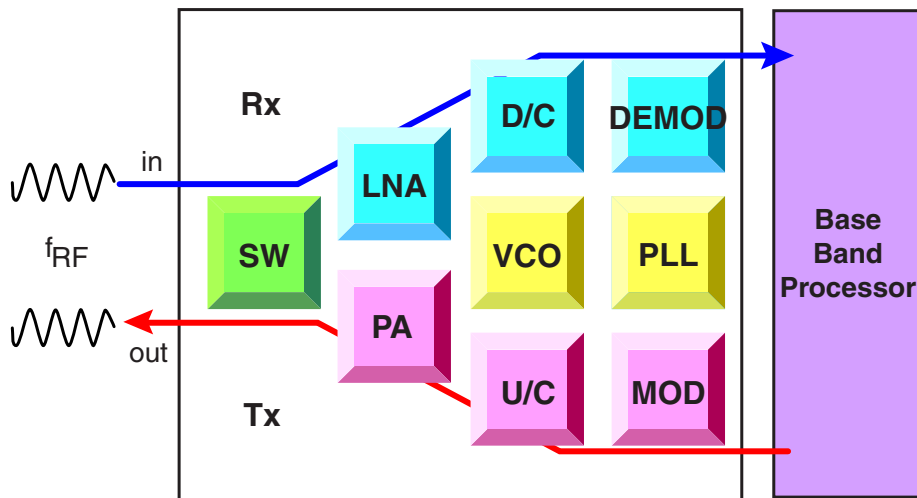

Recommended device list

Block	Function	Type Name	Feature
LNA	Discrete Tr.	2SC5369(NE696M01)	High fr, Low Noise
	Low Noise Amplifier	μ PC2749TB	Low Noise
D/C	Down-converter	μ PC8112TB	6-pin Super Minimold
DEMOD	-	-	-
PLL	PLL	-	-
VCO	Oscillator + Buffer	μ PA8xx Series	Twin Tr.
	Buffer	μ PC8151TB μ PC8179TB	Low Current Consumption
MOD	I/Q Modulator	-	-
U/C	Up-converter	μ PC8106TB	6-pin Super Minimold
PA	Medium Output Power Amplifier	μ PC2762TB	6-pin Super Minimold
		μ PC2763TB	
		μ PC2771TB	
		μ PC8182TB	
SW	SPDT SW	μ PG2009TB	GaAs SW IC, 6-pin Super Minimold
		μ PG2010TB	

<R>

Remark The devices listed in the above table are merely examples. The product recommendation may change depending on the requirements of each system's design.

GSM (Digital Cellular Phone)

RF Front-end Basics

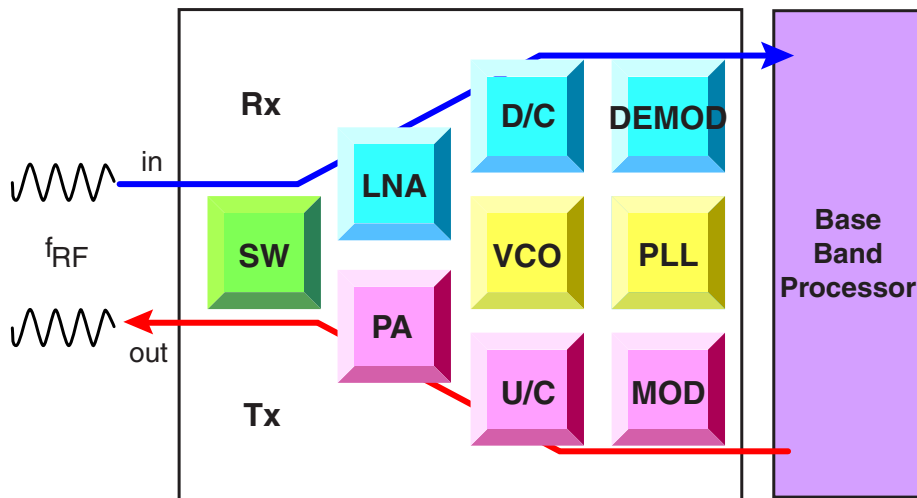

Recommended device list

Block	Function	Type Name	Feature
LNA	Discrete Tr.	2SC5508(NE662M04)	$f_r = 25$ GHz Tr.
D/C	Down-converter	μ PC8112TB	6-pin Super Minimold
DEMOM	I/Q Demodulator	-	-
PLL	Dual PLL	-	-
VCO	Oscillator + Buffer	μ PA8xx Series	Twin Tr.
MOD + U/C	I/Q Modulator	-	-
U/C	Up-converter	μ PC8106TB	6-pin Super Minimold
PA	Driver Amplifier	μ PC2763TB μ PC2771TB μ PC8182TB	6-pin Super Minimold
	Discrete Tr.	2SC5288(NE68939) 2SC5289(NE69039) NE5510279A NE5520379A	Medium Output Power Use Tr.
SW	SPDT SW	μ PG2155TB μ PG2156TB	6-pin Super Minimold

<R>

Remark The devices listed in the above table are merely examples. The product recommendation may change depending on the requirements of each system's design.

System configuration example
GSM (Digital Cellular Phone)
(IF Modulation System)

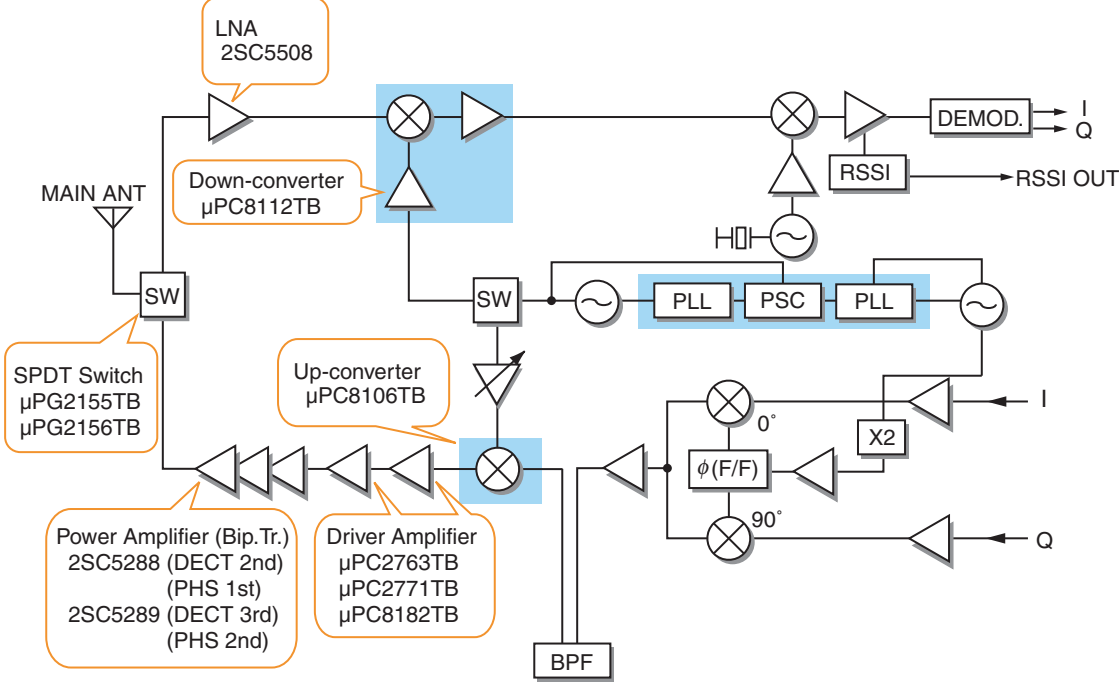

5.8 GHz Digital Cordless Phone

RF Front-end Basics

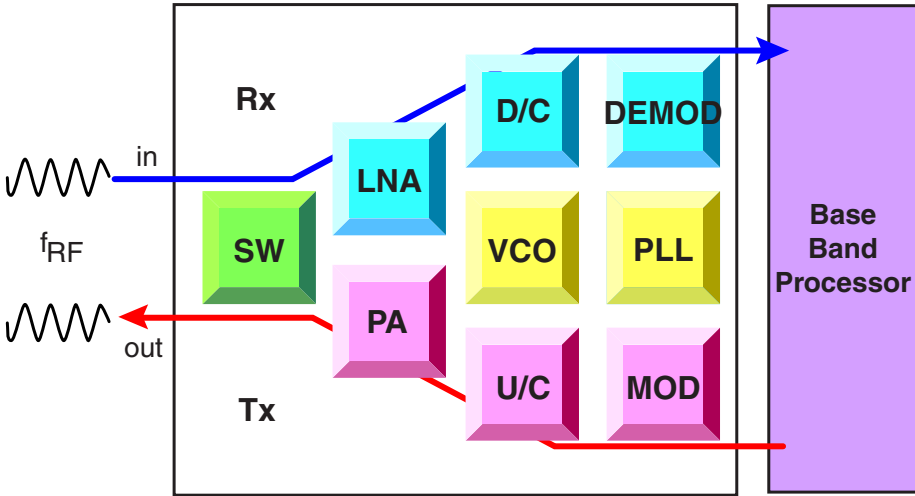

Recommended device list

Block	Function	Type Name	Feature
LNA	Discrete Tr.	2SC5507	Si Bipolar Tr. ($f_T = 25$ GHz)
		2SC5508	
		NESG2021M05/M16	SiGe HBT
		NESG2031M05/M16	
NESG3031M05/M14			
NESG4030M14			
PA	Discrete Tr.	NESG2101M05/M16	SiGe HBT
	PA + Driver	μ PA901TU	SiGe HBT

Remark The devices listed in the above table are merely examples. The product recommendation may change depending on the requirements of each system's design.

900 MHz Cordless Phone (Analog Cordless Phone)

RF Front-end Basics

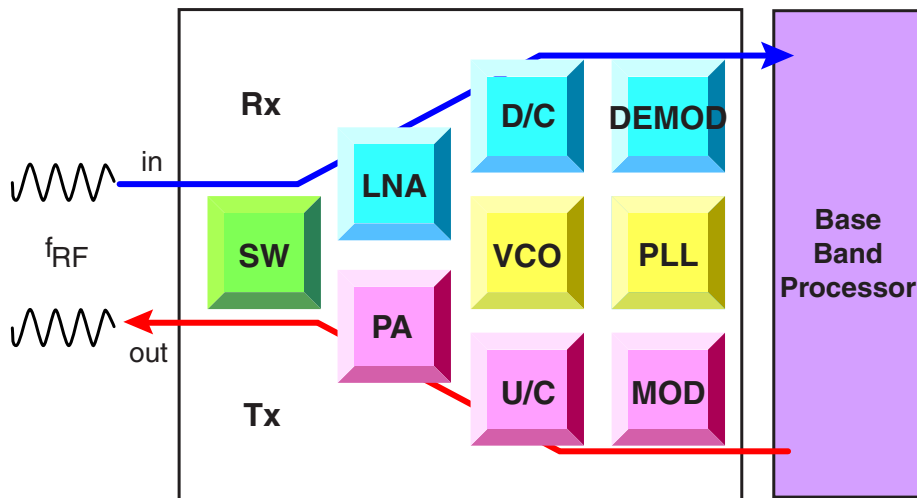

Recommended device list

Block	Function	Type Name	Feature
LNA	Discrete Tr.	2SC4095(NE68039E) 2SC5369(NE696M01) 2SC5507(NE661M04)	High fr, Low Noise
<R>	Down-converter	μ PC8112TB	6-pin Super Minimold
	Discrete Tr.	μ PA8xx Series	Twin Tr. with Different Dice
	PLL	–	–
<R>	Oscillator + Buffer	μ PA8xx Series	Twin Tr. with Different Dice
	Discrete Tr. (Doubler)	2SC5011(NE85618) etc.	$f_r = 7$ GHz
	Buffer	μ PC8151TB μ PC8179TB	Low Current Consumption
<R>	Oscillator	μ PA8xx Series	Twin Tr. with Different Dice
	Discrete Tr. (Doubler)	2SC5011(NE85618) etc.	$f_r = 7$ GHz
	Discrete Tr.	2SC3356(NE85633) etc. 2SC5288(NE68939) 2SC5289(NE69039)	$f_r = 7$ GHz Medium Output Power Use Tr.
<R>		μ PA8xx Series	Twin Tr. with Different Dice
SW	Duplexer	–	–

Remark The devices listed in the above table are merely examples. The product recommendation may change depending on the requirements of each system's design.

System configuration example 1
900 MHz Cordless Phone (Analog Cordless Phone)

<R>

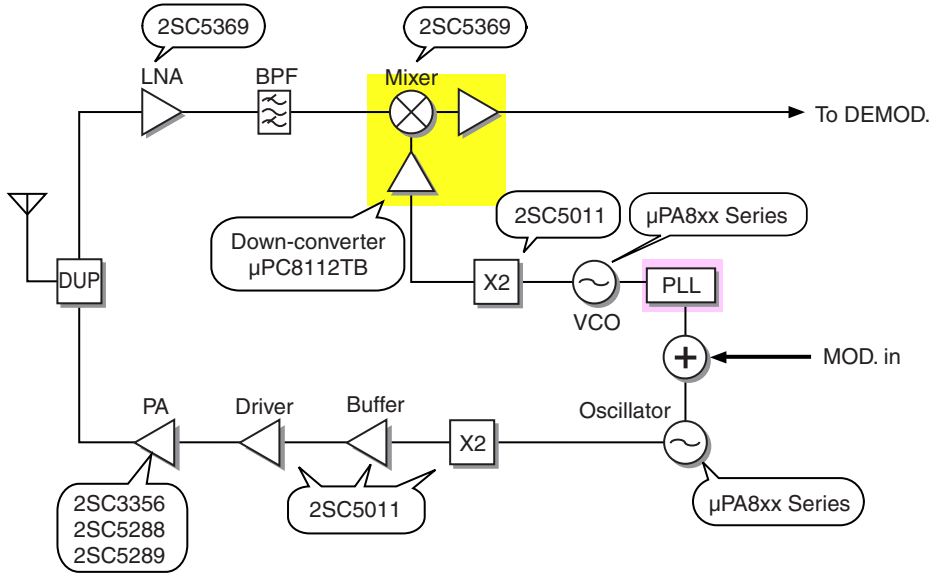

System configuration example 2
900 MHz Cordless Phone (Analog Cordless Phone)

<R>

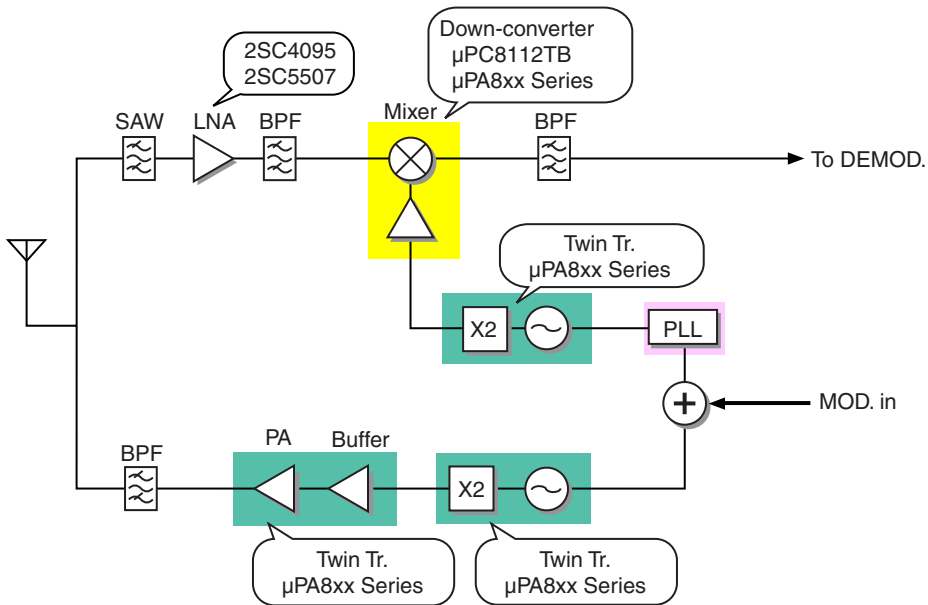

2-2. Multimedia System Digital TV Tuner / Digital CATV Set-top-box

RF Front-end Basics

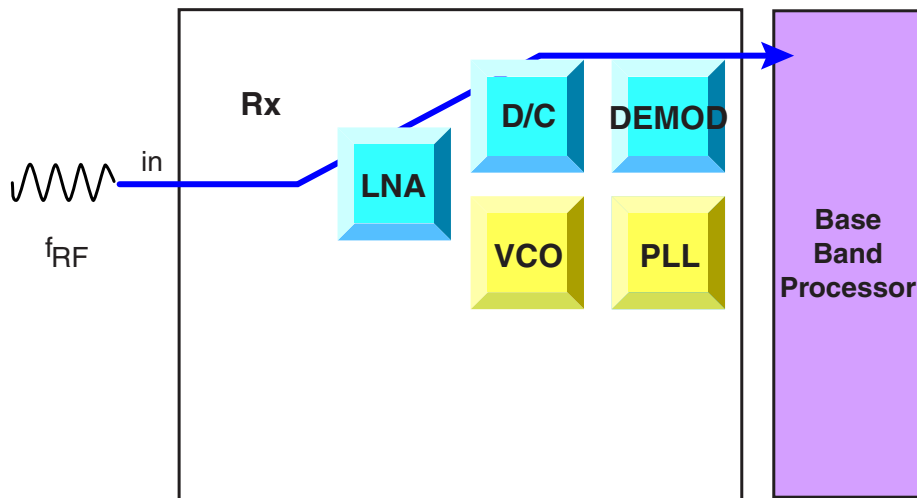

<R>

Recommended device list

Block	Function	Type Name	Feature
LNA	Discrete Tr.	2SC3357(NE85634)	Si Tr. Suitable for more than 5-6 V operation Low Distortion, Low Noise
		2SC4536(NE46134)	
		2SC4703(NE46234)	
		2SC5336(NE856M02)	
		2SC5337(NE461M02)	
		2SC5338(NE462M02)	
	MMIC	2SC5754(NE664M04)	Si Tr. Suitable for less than 5-6 V operation Low Distortion, Low Noise
		NESG2101M05/M16	SiGe HBT Suitable for less than 5-6 V operation Low Distortion, Low Noise
		NESG210719	
		NESG210833	
NESG220033/34			
DEMOD	AGC Amplifier + Video Amplifier	μPC2748TB	Si MMIC, Low Noise
		μPC3237TK	SiGe MMIC, Low Noise
		μPD5740T6N	MMIC with pass-through function, Low Noise
D/C + AGC	IF Down-converter	μPC3217GV	Middle-gain Type
		μPC3218GV	High-gain Type
		μPC3219GV, μPC3221GV	Low-gain, High-linearity Type
		μPC3231GV	
D/C + AGC	IF Down-converter	μPC3234GV	High-gain, Low Noise Type
		μPC3220GR	High-gain
		μPC3228T5S	Low Distortion

Remark The devices listed in the above table are merely examples. The product recommendation may change depending on the requirements of each system's design.

System configuration example 1

Example of receiver block for digital CATV Set-top-box

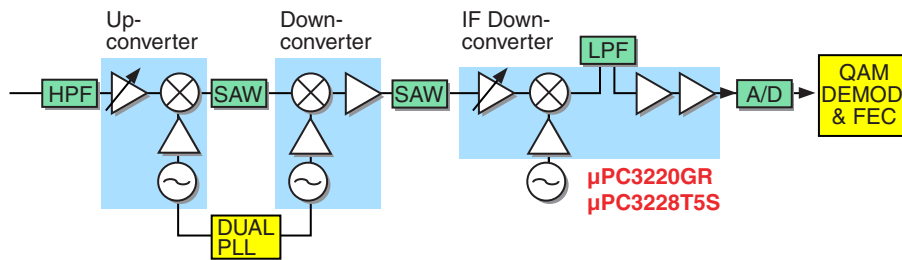

System configuration example 2

<R>

Example of receiver block for digital CATV Set-top-box

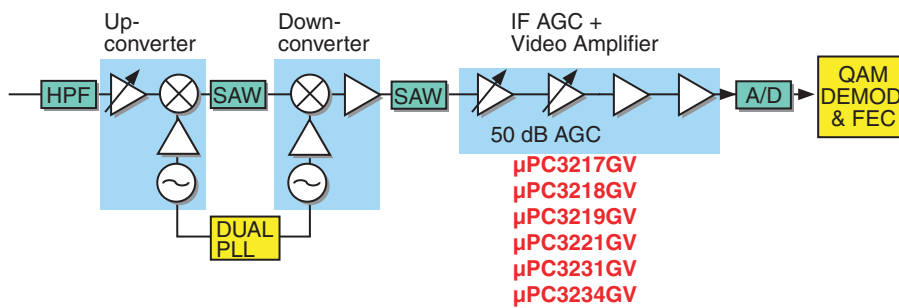

Digital DBS (Satellite Broadcasting)

RF Front-end Basics

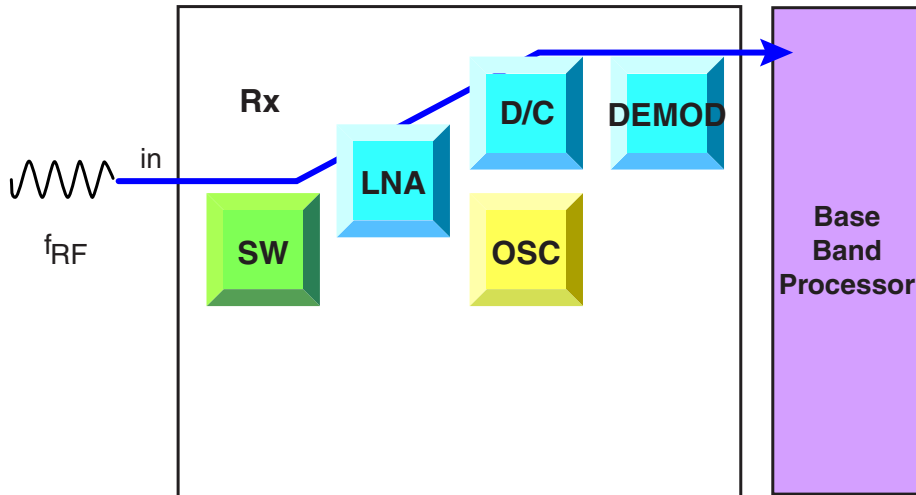

Recommended device list

Block	Function	Type Name	Feature
LNA	LNA	HJ-FET Series	GaAs HJ-FET Series for X, Ku-band, 20 GHz band
	IF Amplifier	μ PC3224TB	$G_P = 21.5 \text{ dB}$, $P_{O(1 \text{ dB})} = -5.5 \text{ dBm}$
		μ PC3227TB	$G_P = 22.0 \text{ dB}$, $P_{O(1 \text{ dB})} = -8.0 \text{ dBm}$
		μ PC3240TB	$G_P = 25.0 \text{ dB}$, $P_{O(1 \text{ dB})} = -4.0 \text{ dBm}$ (3.3 V)
		μ PC3242TB	$G_P = 22.0 \text{ dB}$, $P_{O(1 \text{ dB})} = -9.5 \text{ dBm}$ (3.3 V)
	Medium Output Power Amplifier	μ PC3223TB	$G_P = 23.0 \text{ dB}$, $P_{O(1 \text{ dB})} = +5.0 \text{ dBm}$
		μ PC3226TB	$G_P = 26.0 \text{ dB}$, $P_{O(1 \text{ dB})} = +5.7 \text{ dBm}$
		μ PC3232TB	$G_P = 33.5 \text{ dB}$, $P_{O(1 \text{ dB})} = +8.5 \text{ dBm}$
		μ PC3236TK	$G_P = 38.0 \text{ dB}$, $P_{O(1 \text{ dB})} = +7.5 \text{ dBm}$
		μ PC3239TB	$G_P = 25.0 \text{ dB}$, $P_{O(1 \text{ dB})} = +8.0 \text{ dBm}$ (3.3 V)
μ PC3241TB		$G_P = 24.0 \text{ dB}$, $P_{O(1 \text{ dB})} = +6.0 \text{ dBm}$ (3.3 V)	
OSC	DRO	2SC5508(NE662M04) 2SC5606(NE66219) NESG2031M05/M16	Low Phase Noise
	Buffer	NE3515S02	$P_{O(1 \text{ dB})} = +14 \text{ dBm}$
SW	Switch Matrix	μ PD5716GR	ISL D/U Ratio = 29 dB
		μ PD5720K	ISL D/U Ratio = 34 dB
		μ PG2054K	ISL D/U Ratio = 40 dB

Remark The devices listed in the above table are merely examples. The product recommendation may change depending on the requirements of each system's design.

**System configuration example
Digital DBS (Satellite Broadcasting)**

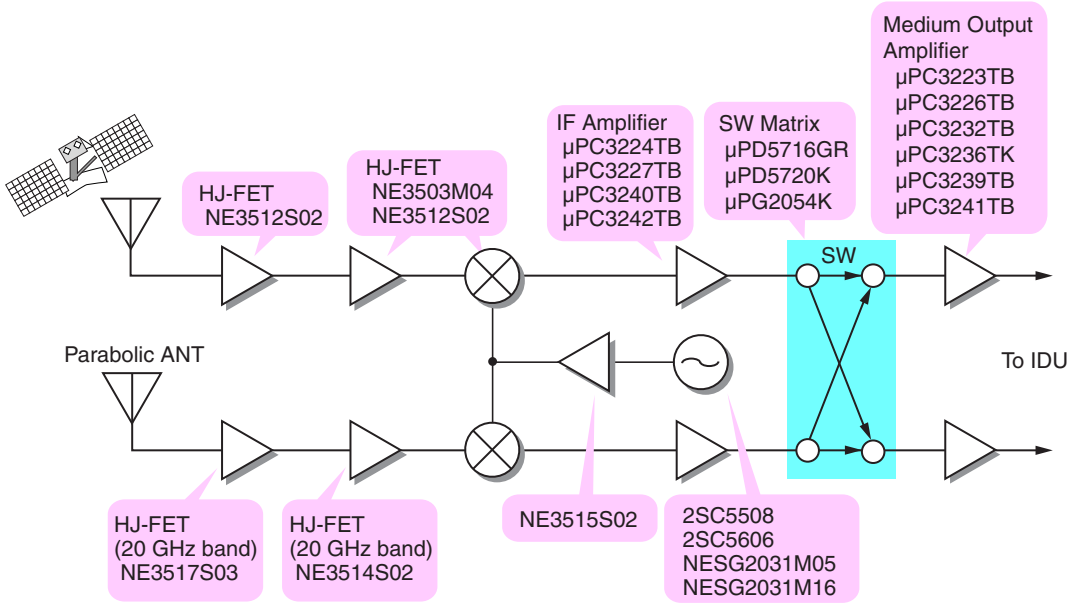

Cable Modem

RF Front-end Basics

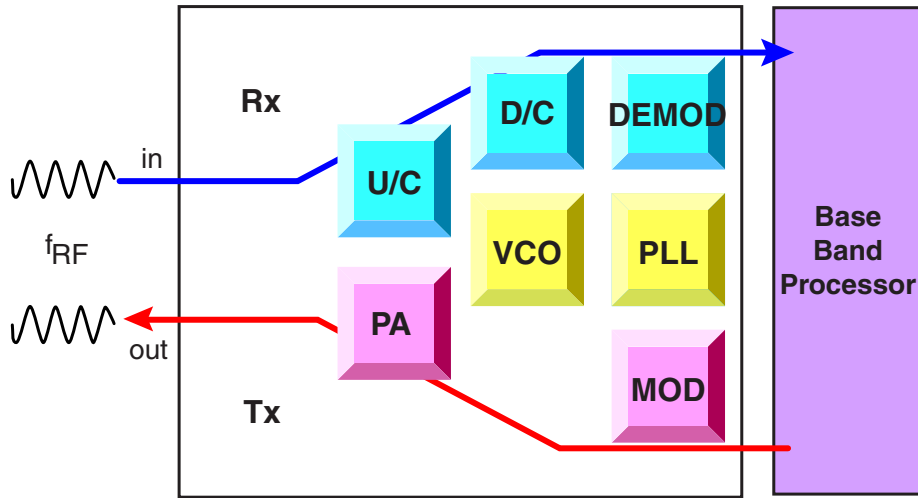

<R>

Recommended device list

Block	Function	Type Name	Feature
U/C + VCO	U/C + VCO	-	-
D/C + VCO	D/C + VCO	-	-
DEMOD	AGC Amplifier + Video Amplifier	μ PC3217GV	Middle-gain Type
		μ PC3218GV	High-gain Type
		μ PC3219GV	Low-gain, High-linearity Type
		μ PC3221GV	
		μ PC3231GV	High-gain, Low Noise Type
D/C + AGC	IF Down-converter	μ PC3220GR	High-gain
		μ PC3228T5S	Low Distortion
PLL	PLL	-	-
VCO	-	-	-
MOD	-	-	-
PA	Discrete Tr.	2SC5338(NE462M02)	Power Minimold

Remark The devices listed in the above table are merely examples. The product recommendation may change depending on the requirements of each system's design.

System configuration example 1

Example of transceiver block for Cable Modem Set-top-box

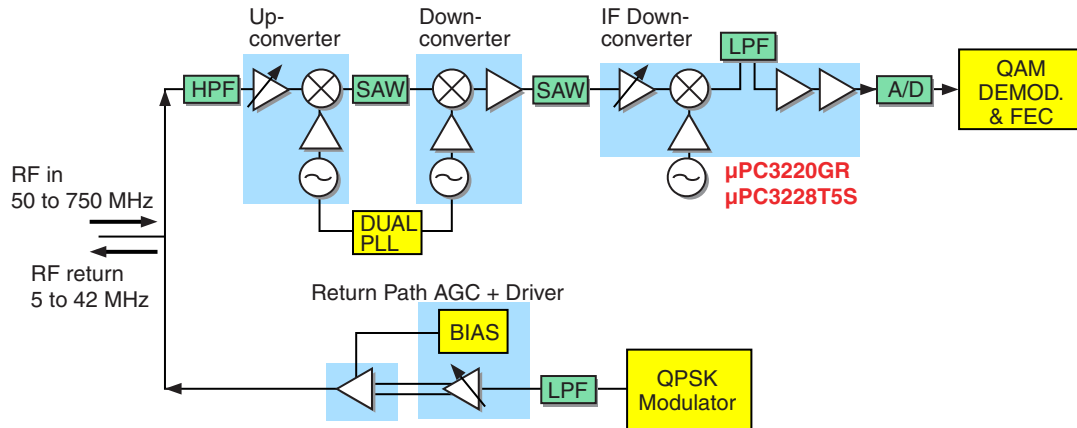

System configuration example 2

<R>

Example of transceiver block for Cable Modem Set-top-box

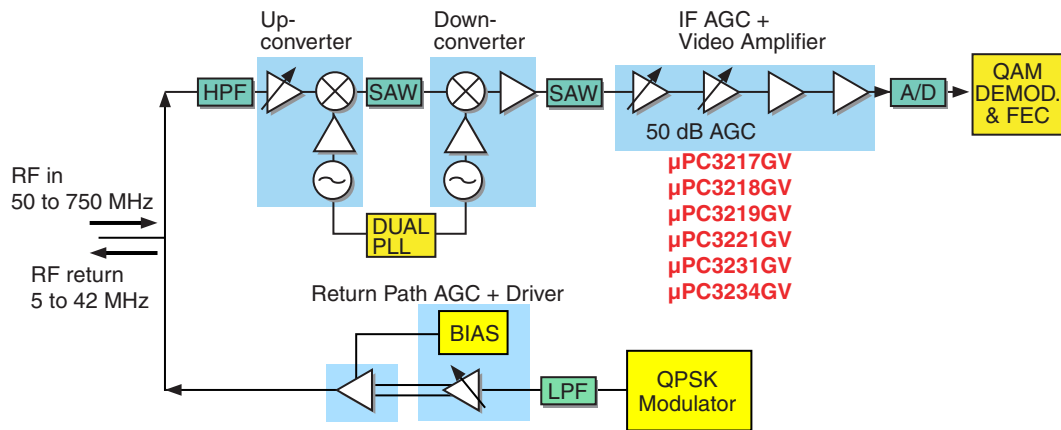

2-3. Others
GPS

RF Front-end Basics

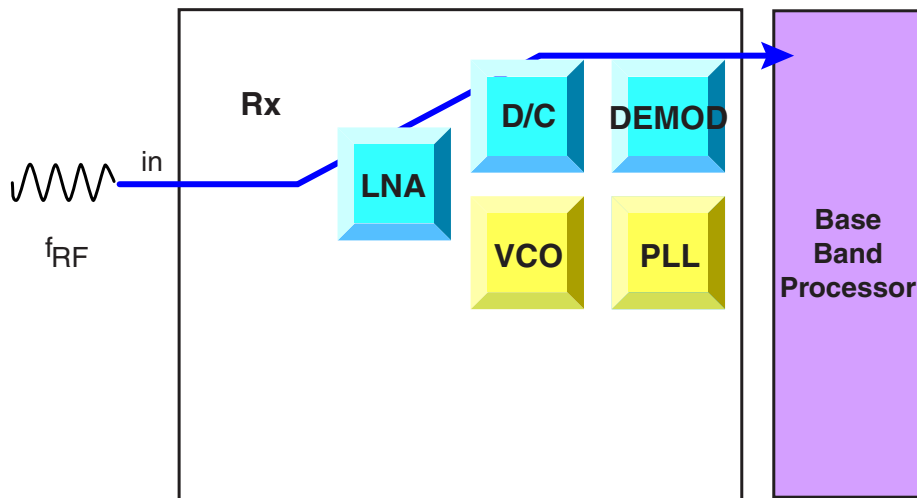

Recommended device list

Block	Function	Type Name	Feature
LNA	1st stage	NE3508M04 NE3509M04 NE3509M14	GaAs HJ-FET
		NESG3032M14 NESG3033M14	SiGe Tr.
		μ PC8230TU μ PC8231TK μ PC8232T5N μ PC8233TK μ PC8236T6N μ PC8240T6N	SiGe:C MMIC
	2nd stage or later	μ PC2749TB	Low Noise, Si MMIC
	Discrete Tr.	2SC5507(NE661M04) 2SC5508(NE662M04)	Si Bipolar Tr. ($f_T = 25$ GHz)
RF SINGLE CHIP	Pre-Amplifier + 1st Down-converter + 2nd Down-converter + OP Amplifier + PLL + Oscillator + Buffer	μ PB1007K	Low Current Consumption, Built-in Power Saving Function

Remark The devices listed in the above table are merely examples. The product recommendation may change depending on the requirements of each system's design.

System configuration example
GPS

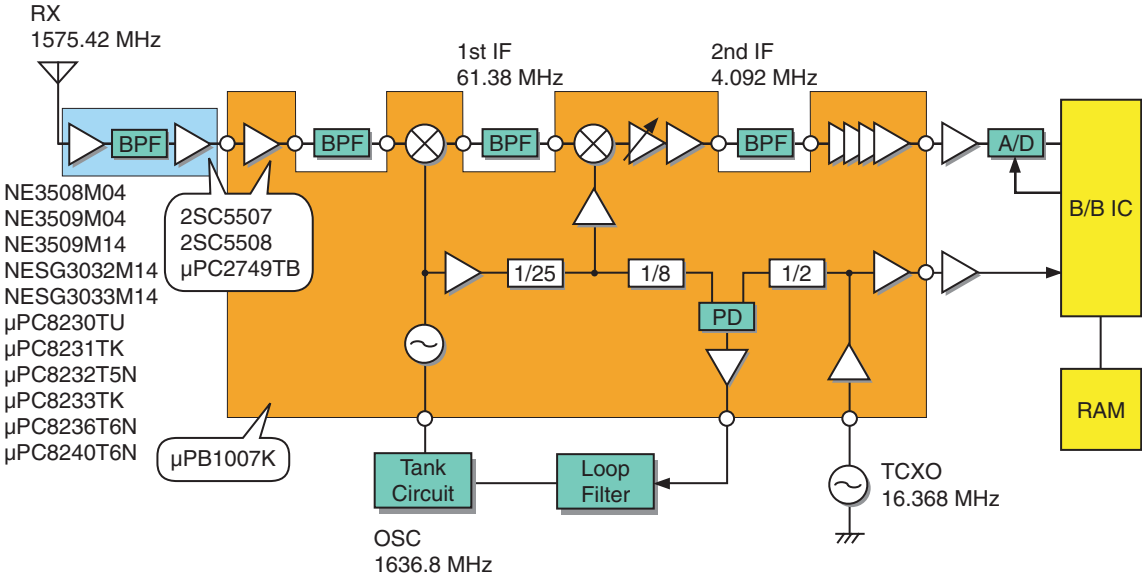

FRS (Family Radio Service) / GMRS (General Mobile Radio Service)

RF Front-end Basics

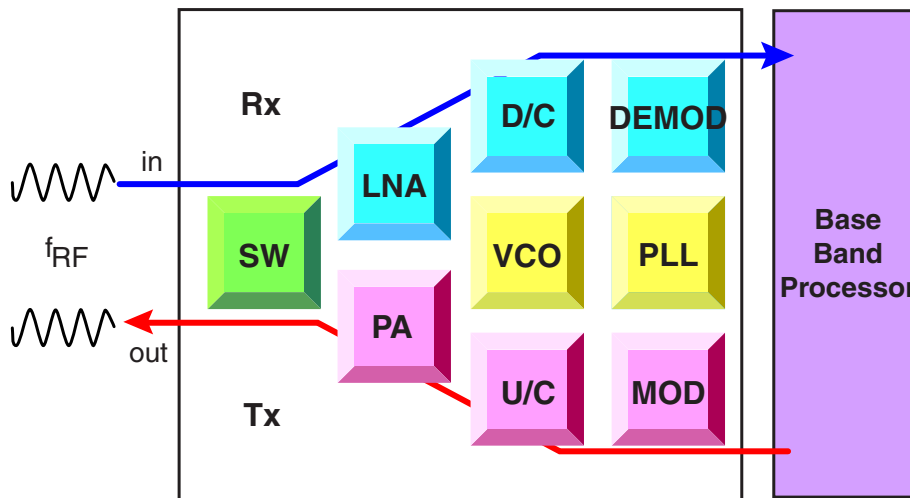

Recommended device list

Block	Function	Type Name	Feature	
LNA	Discrete Tr.	2SC4226(NE85630) 2SC5006(NE85619)	Low Noise, High Gain	
D/C	Discrete Tr.	2SC4226(NE85630) 2SC5006(NE85619)	Low Noise, High Gain	
DEMOM	-	-	-	
PLL	PLL	-	-	
VCO	Discrete Tr.	2SC4226(NE85630) 2SC5006(NE85619)	Low Current Consumption	
MOD	-	-	-	
U/C	-	-	-	
PA	Discrete Tr.	2SC4226(NE85630)	Driver Use Tr.	
		2SC5006(NE85619)		
		2SC5751(NE677M04)		
		2SC5753(NE678M04)		
		2SC5754(NE664M04)		Output: 100 mW class
		NESG250134		Output: 800 mW class
		NESG260234		Output: 1 W class
	NESG270034	Output: 2 W class		
Si LDMOS		NE5500179A, NE552R679A	Output: 500 mW class	
		NE5500234, NE5500479A NE5510279A, NE5511279A NE5520279A, NE5520379A NE5531079A	Output: 2 W class or higher	
SW	-	-	-	

Remark The devices listed in the above table are merely examples. The product recommendation may change depending on the requirements of each system's design.

System configuration example
460 MHz FRS

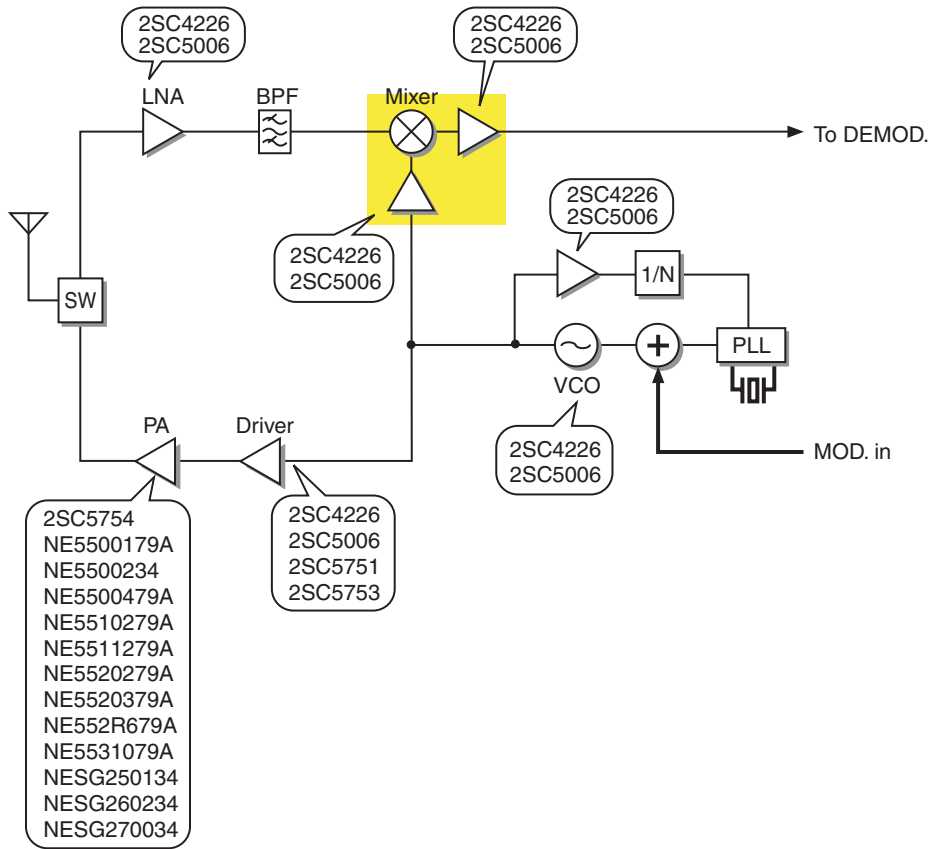

PA Selection Map

GMRS MURS	5 W (37 dBm)			NE5511279A NE5531079A
	3 W (34.8 dBm)	NE5520279A NE5520379A	NE5500234 NE5510279A NE5520379A	NE5500479A NESG270034
	2 W (33 dBm)			
FRS PMR	1 W (30 dBm)		NE5500179A NESG260234	
	0.5 W (27 dBm)	NE552R679A NESG250134		
LPD	0.1 W (20 dBm)	2SC5754		
		3 to 3.2 V	4.5 to 4.8 V	6 V

Bluetooth

RF Front-end Basics

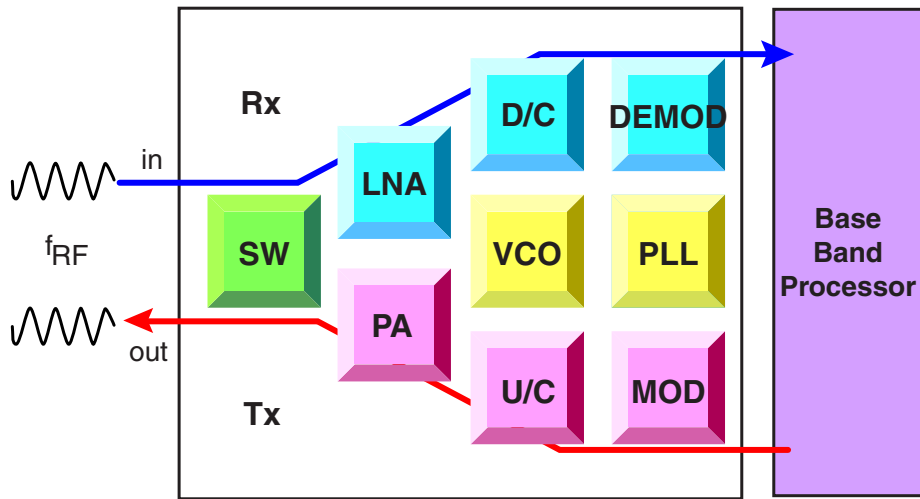

Recommended device list

Block	Function	Type Name	Feature
LNA	-	-	-
D/C	-	-	-
DEMOM	-	-	-
PLL	-	-	-
VCO	-	-	-
MOD	-	-	-
U/C	-	-	-
PA	-	μ PG2250T5N μ PG2251T6M μ PG2314T5N 2SC5754(NE664M04) NE552R479A	GaAs MMIC Si Tr. Si LDMOS FET
FEIC	PA + SW + Filter	μ PG2253T6S	GaAs MMIC
SW	SPDT SW	μ PG2214TB μ PG2214TK	GaAs SW IC, 6-pin Super Minimold GaAs SW IC, 6-pin Lead-less Minimold (1511)

Remark The devices listed in the above table are merely examples. The product recommendation may change depending on the requirements of each system's design.

System configuration example
Bluetooth

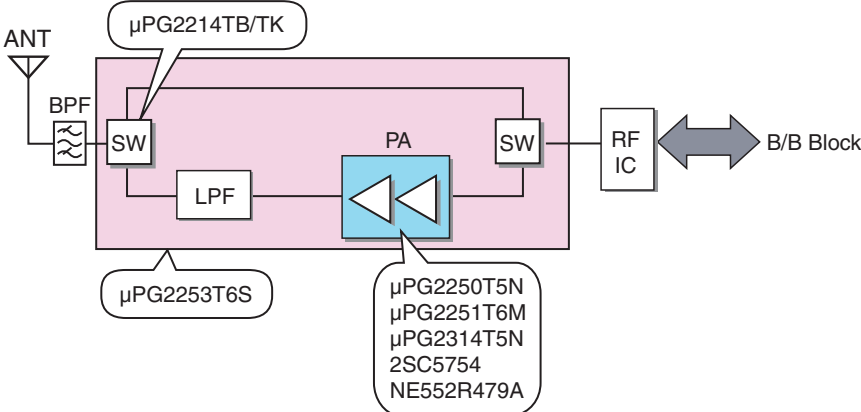

2.4 GHz Wireless LAN

RF Front-end Basics

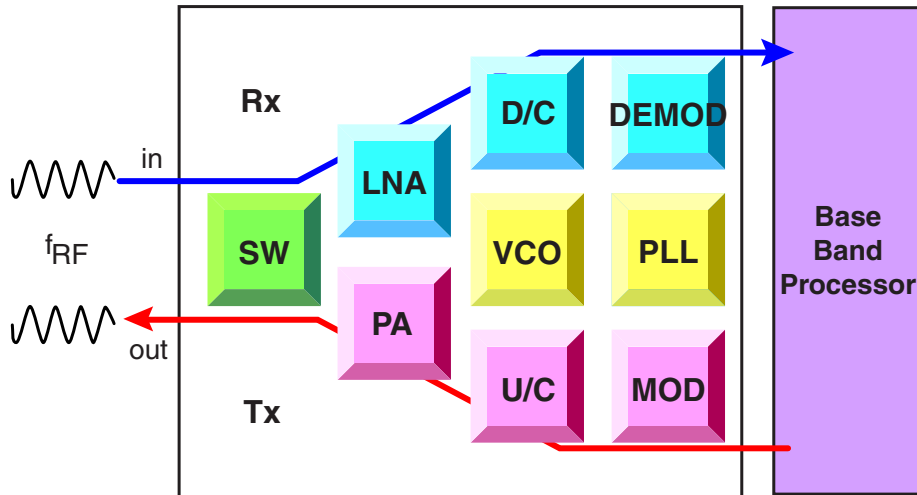

<R>

Recommended device list

Block	Function	Type Name	Feature
LNA	Discrete Tr.	2SC5508(NE662M04)	Si Bipolar Tr. ($f_T = 25$ GHz)
		2SC5509(NE663M04)	Si Bipolar Tr. ($f_T = 17$ GHz)
		NESG2021M05, NESG2031M05	SiGe HBT
D/C	Down-converter	-	-
DEMOD	-	-	-
PLL	PLL	-	-
VCO	Oscillator + Buffer	2SC5004(NE58219), 2SC5011(NE85618) 2SC5801(NE851M13)	-
	Buffer	2SC5015(NE68518), 2SC5185(NE68718) μ PC8178TB/TK, μ PC8179TB/TK	Low Current Consumption
MOD	I/Q Modulator	-	-
U/C	Up-converter	μ PC8172TB, μ PC8187TB	6-pin Super Minimold
PA	-	μ PG2318T5N	GaAs MMIC
		2SC5288(NE68939), 2SC5289(NE69039) 2SC5754(NE664M04) NESG2101M05	Medium Output Power Use Tr.
		NE552R479A	Medium Output Power (0.4 W) Si LDMOS FET
		-	-
SW	SPDT SW	μ PG2179TB	6-pin Super Minimold
		μ PG2030TK	6-pin Lead-less Minimold (1511)
		μ PG2406T6R	6-pin TSSON

Remark The devices listed in the above table are merely examples. The product recommendation may change depending on the requirements of each system's design.

System configuration example (IF Modulation System)

<R>

2.4 GHz Wireless LAN

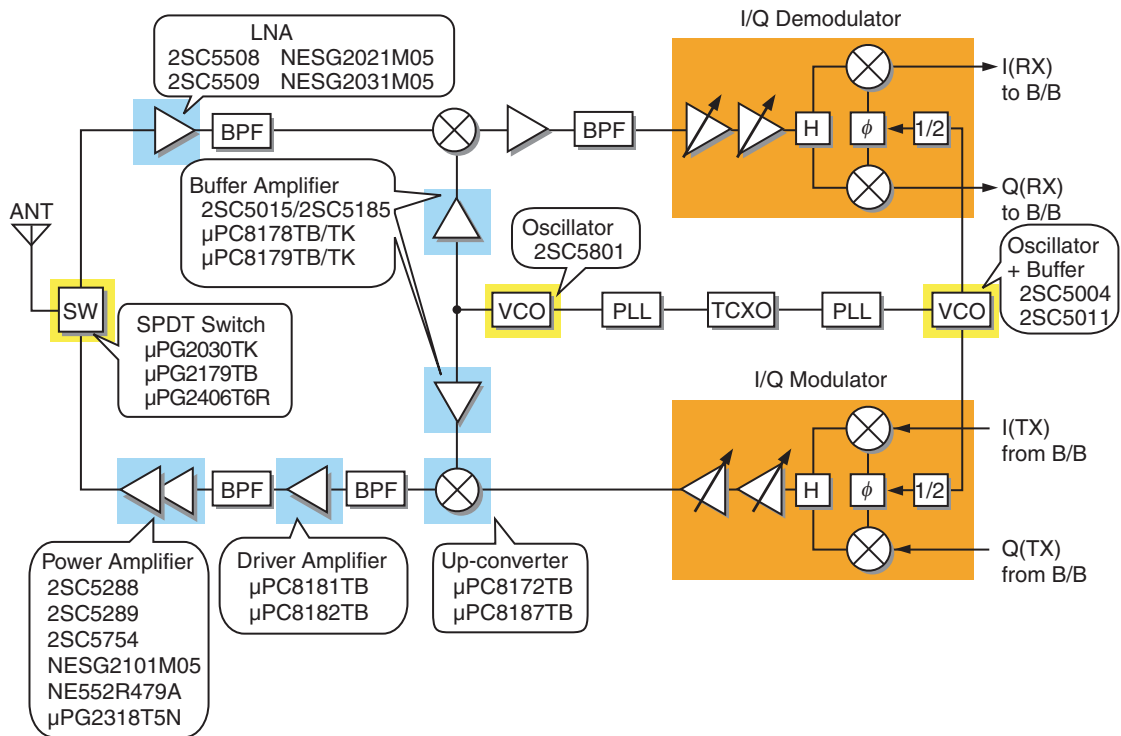

5 GHz Wireless LAN

RF Front-end Basics

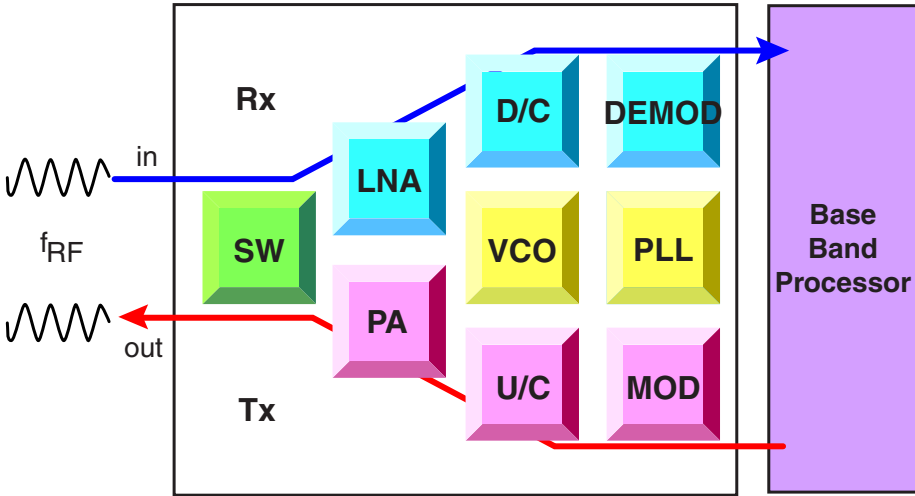

Recommended device list

Block	Function	Type Name	Feature
LNA	Discrete Tr.	NESG3031M05 NESG4030M14	SiGe HBT
PA	Discrete Tr.	NESG2101M05	SiGe HBT

Remark The devices listed in the above table are merely examples. The product recommendation may change depending on the requirements of each system's design.

System configuration example 1
5 GHz Wireless LAN

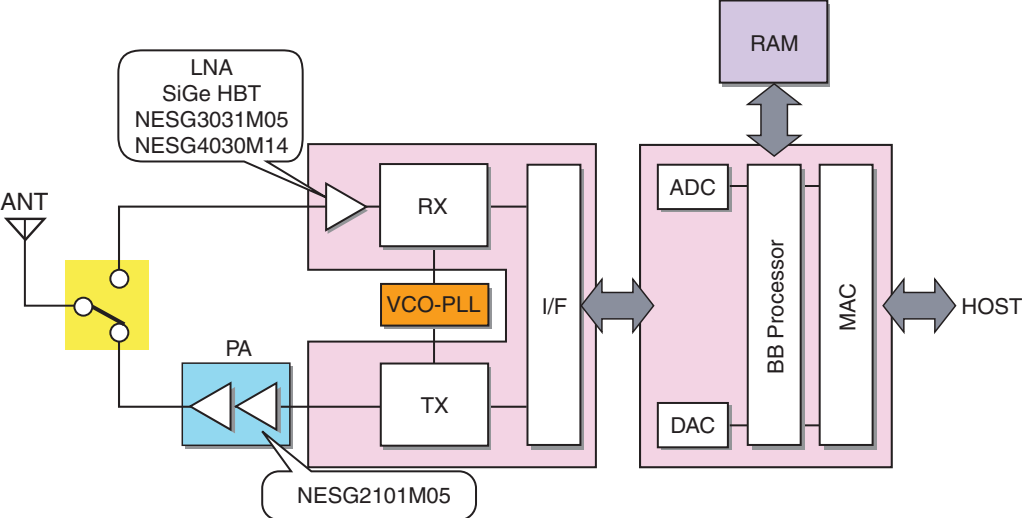

System configuration example 2
5 GHz Wireless LAN
(Antenna Diversity)

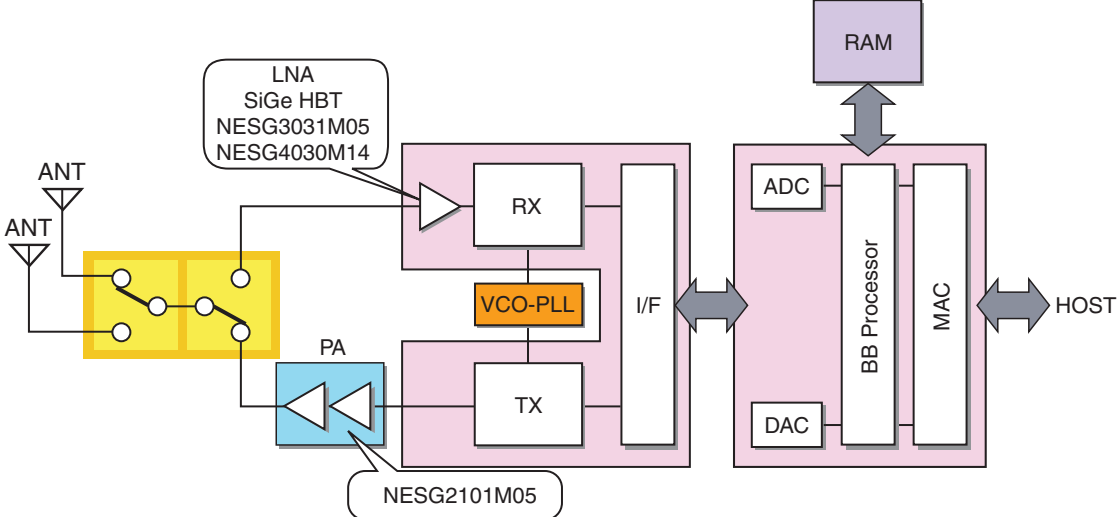

2.4 GHz & 5 GHz Dualband Wireless LAN

RF Front-end Basics

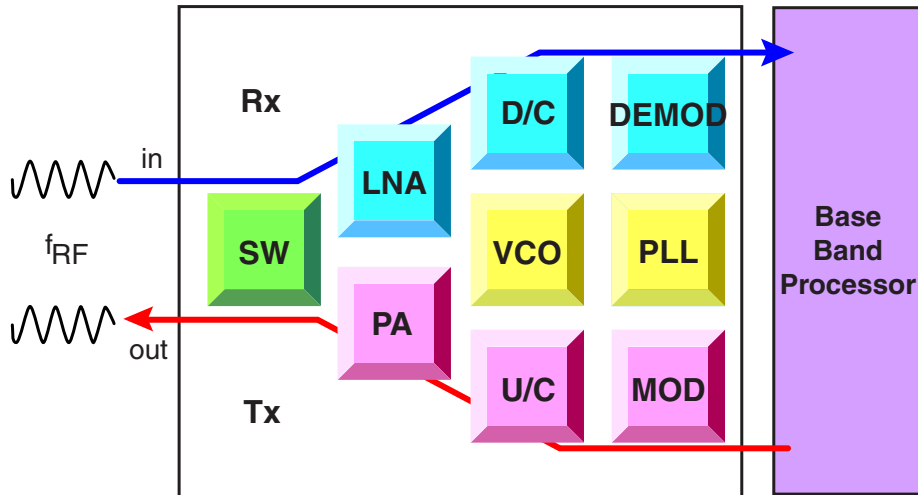

Recommended device list

Block	Function	Type Name	Feature
LNA	Discrete Tr.	NESG3031M05 NESG3031M14 NESG4030M14	SiGe HBT
SW	SPDT SW	μ PG2163T5N	GaAs SW IC, Low Insertion Loss, High Isolation, 6-pin TSON
		μ PG2185T6R	GaAs SW IC, 6-pin TSSON (1.0 × 1.0 × 0.37 mm, Small and Thin Package)
	DPDT SW	μ PG2162T5N	GaAs SW IC, High Isolation, 6-pin TSON
		μ PG2164T5N	GaAs SW IC, Low Insertion Loss, 6-pin TSON

Remark The devices listed in the above table are merely examples. The product recommendation may change depending on the requirements of each system's design.

N-CDMA, GSM Cellular Phone Base Station (900 MHz Band)

RF Front-end Basics

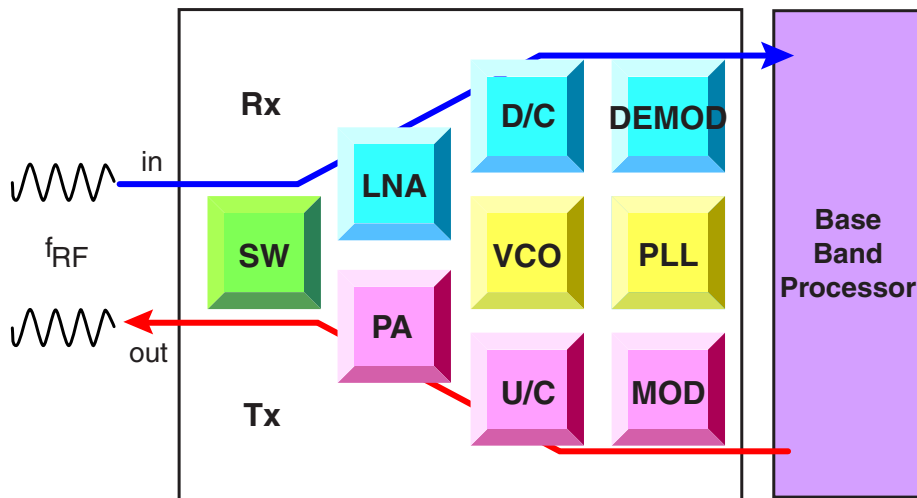

Recommended device list

Block	Function	Type Name	Feature
LNA	Discrete Tr.	2SC5508(NE662M04)	Si Bipolar Tr. ($f_T = 25$ GHz)
		NESG2031M05	SiGe HBT
		NESG2031M16	
PA	PA Driver	NE55410GR	2 W + 10 W Driver
	High Power LDMOS FET	NEM090303M-28	Single-end Type, Low Distortion, High Output Power
		NEM090603M-28	
		NEM090853P-28	
		NEM091203P-28	
	NEM091803S-28	Push-pull Type, Low Distortion, High Output Power	

Remark The devices listed in the above table are merely examples. The product recommendation may change depending on the requirements of each system's design.

W-CDMA Cellular Phone Base Station

RF Front-end Basics

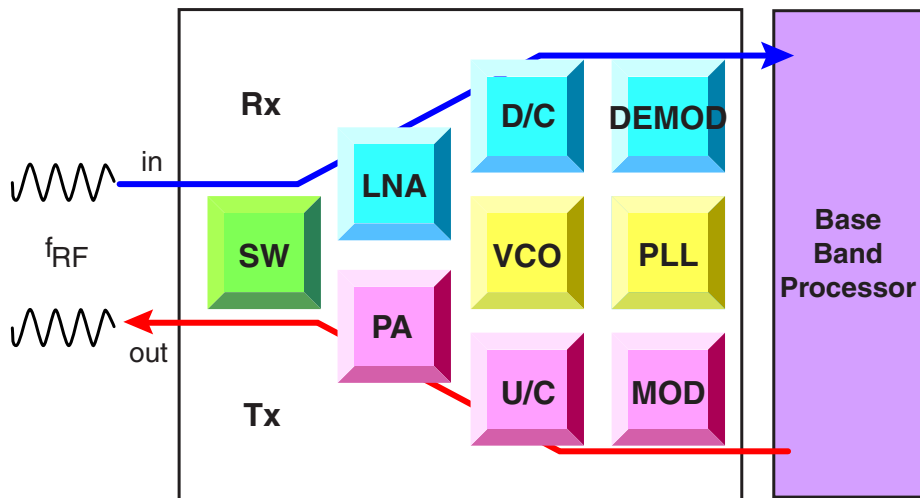

<R>

Recommended device list

Block	Function	Type Name	Feature
LNA	Discrete Tr.	2SC5508(NE662M04)	Si Bipolar Tr. ($f_T = 25$ GHz)
		NESG2031M05	SiGe HBT
		NESG2031M16	
PA	PA Driver	NE55410GR	2 W + 10 W Driver Si LDMOS FET

Remark The devices listed in the above table are merely examples. The product recommendation may change depending on the requirements of each system's design.

<R> **3. WEB SITE INFORMATION**

The RF and Microwave Devices homepage has many documents available for viewing or downloaded. Please see our web site. The our web site address is as follows;

RF and Microwave Devices

<http://www2.renesas.com/microwave/en/index.html>

The screenshot shows the Renesas website for RF and Microwave Devices. At the top, there is a navigation bar with links for 'About Renesas', 'Press Center', 'Events', 'Investor Relations', and 'Contact Us'. A 'Region' dropdown is set to 'Global', and language options for Japanese, Korean, Simplified Chinese, and Traditional Chinese are available. The Renesas logo is on the left, and a search bar is on the right. Below the navigation bar, a dark blue banner contains the text 'Products > Discrete >' and 'RF and Microwave Devices'. A 'Provide feedback' and 'Print this page' button is on the right. A red warning icon indicates that the page content corresponds to products formerly marketed by NEC Electronics. A sidebar on the left lists navigation options: 'Former NEC Electronics RF and Microwave Devices Home', 'Product Lineup', 'Application', 'Cross-reference', 'Documentation', 'Development Data Download', and 'Search within RF and Microwave Devices site'. A 'Opto/RF and Microwave Devices Mailing Service' button is also present. The main content area features a large blue banner with 'RF and Microwave Devices' and images of components. Below this are two columns: 'Product Lineup' with links for 'New Products', 'Product Lineup^{UP} IC / Discrete / MCM', and 'Cross-reference' (with a description of a cross-reference table); and 'Application' with links for 'System Introduction', 'Basic RF Blocks', and 'System Block Diagrams^{UP}' (with a description of selecting products for block diagrams). A 'Development Data Download' section includes 'Device Parameters^{UP}' (with a description of free-of-charge simulator libraries) and logos for Agilent Technologies, ANSOFT, and Microwave office. Other sections include 'CAD Data List', 'Evaluation Board Information^{UP}', 'Information' (with a link to a technical journal), and 'Site Updates' (with a link to documents added on April 14). At the bottom, there are links for 'Archive' and 'Back To Top'. The footer contains copyright information for 1995-2010 Renesas Electronics Corporation and links for 'World Renesas', 'Using Our Website', 'Privacy', 'RSS', and 'Sitemap'.

Revisions History

Rev.	Date	Description	
		Page	Summary
1.00	2010.4	Throughout	μPA86x Series -> μPA8xx Series
		pp.11-13, 32, 33	Deletion of μPG2158T5K
		pp. 20, 21, 24, 25	Deletion of μPC3218T5Y
		p.38	Deletion of NES1823M-45, NES1823M-180, NES1823M-240, NES1823S-45, NES1823S-90
		p.39	Modification of 3. WEB SITE INFORMATION

This document covers “Silicon Microwave Transistors”, “Silicon Microwave Monolithic ICs” and “Microwave GaAs Devices”.

Caution	GaAs Products	<p>This product uses gallium arsenide (GaAs). GaAs vapor and powder are hazardous to human health if inhaled or ingested, so please observe the following points.</p> <ul style="list-style-type: none">• Follow related laws and ordinances when disposing of the product. If there are no applicable laws and/or ordinances, dispose of the product as recommended below.<ol style="list-style-type: none">1. Commission a disposal company able to (with a license to) collect, transport and dispose of materials that contain arsenic and other such industrial waste materials.2. Exclude the product from general industrial waste and household garbage, and ensure that the product is controlled (as industrial waste subject to special control) up until final disposal.• Do not burn, destroy, cut, crush, or chemically dissolve the product.• Do not lick the product or in any way allow it to enter the mouth.
----------------	---------------	--

Bluetooth is a trademark owned by Bluetooth SIG, Inc., U.S.A.

Renesas Electronics Corporation

Notes:

1. All information included in this document is current as of the date this document is issued. Such information, however, is subject to change without any prior notice. Before purchasing or using any Renesas Electronics products listed herein, please confirm the latest product information with a Renesas Electronics sales office. Also, please pay regular and careful attention to additional and different information to be disclosed by Renesas Electronics such as that disclosed through our website.
 2. Renesas Electronics does not assume any liability for infringement of patents, copyrights, or other intellectual property rights of third parties by or arising from the use of Renesas Electronics products or technical information described in this document. No license, express, implied or otherwise, is granted hereby under any patents, copyrights or other intellectual property rights of Renesas Electronics or others.
 3. You should not alter, modify, copy, or otherwise misappropriate any Renesas Electronics product, whether in whole or in part.
 4. Descriptions of circuits, software and other related information in this document are provided only to illustrate the operation of semiconductor products and application examples. You are fully responsible for the incorporation of these circuits, software, and information in the design of your equipment. Renesas Electronics assumes no responsibility for any losses incurred by you or third parties arising from the use of these circuits, software, or information.
 5. When exporting the products or technology described in this document, you should comply with the applicable export control laws and regulations and follow the procedures required by such laws and regulations. You should not use Renesas Electronics products or the technology described in this document for any purpose relating to military applications or use by the military, including but not limited to the development of weapons of mass destruction. Renesas Electronics products and technology may not be used for or incorporated into any products or systems whose manufacture, use, or sale is prohibited under any applicable domestic or foreign laws or regulations.
 6. Renesas Electronics has used reasonable care in preparing the information included in this document, but Renesas Electronics does not warrant that such information is error free. Renesas Electronics assumes no liability whatsoever for any damages incurred by you resulting from errors in or omissions from the information included herein.
 7. Renesas Electronics products are classified according to the following three quality grades: "Standard", "High Quality", and "Specific". The recommended applications for each Renesas Electronics product depends on the product's quality grade, as indicated below. You must check the quality grade of each Renesas Electronics product before using it in a particular application. You may not use any Renesas Electronics product for any application categorized as "Specific" without the prior written consent of Renesas Electronics. Further, you may not use any Renesas Electronics product for any application for which it is not intended without the prior written consent of Renesas Electronics. Renesas Electronics shall not be in any way liable for any damages or losses incurred by you or third parties arising from the use of any Renesas Electronics product for an application categorized as "Specific" or for which the product is not intended where you have failed to obtain the prior written consent of Renesas Electronics. The quality grade of each Renesas Electronics product is "Standard" unless otherwise expressly specified in a Renesas Electronics data sheets or data books, etc.
"Standard": Computers; office equipment; communications equipment; test and measurement equipment; audio and visual equipment; home electronic appliances; machine tools; personal electronic equipment; and industrial robots.
"High Quality": Transportation equipment (automobiles, trains, ships, etc.); traffic control systems; anti-disaster systems; anti-crime systems; safety equipment; and medical equipment not specifically designed for life support.
"Specific": Aircraft; aerospace equipment; submersible repeaters; nuclear reactor control systems; medical equipment or systems for life support (e.g. artificial life support devices or systems), surgical implantations, or healthcare intervention (e.g. excision, etc.), and any other applications or purposes that pose a direct threat to human life.
 8. You should use the Renesas Electronics products described in this document within the range specified by Renesas Electronics, especially with respect to the maximum rating, operating supply voltage range, movement power voltage range, heat radiation characteristics, installation and other product characteristics. Renesas Electronics shall have no liability for malfunctions or damages arising out of the use of Renesas Electronics products beyond such specified ranges.
 9. Although Renesas Electronics endeavors to improve the quality and reliability of its products, semiconductor products have specific characteristics such as the occurrence of failure at a certain rate and malfunctions under certain use conditions. Further, Renesas Electronics products are not subject to radiation resistance design. Please be sure to implement safety measures to guard them against the possibility of physical injury, and injury or damage caused by fire in the event of the failure of a Renesas Electronics product, such as safety design for hardware and software including but not limited to redundancy, fire control and malfunction prevention, appropriate treatment for aging degradation or any other appropriate measures. Because the evaluation of microcomputer software alone is very difficult, please evaluate the safety of the final products or system manufactured by you.
 10. Please contact a Renesas Electronics sales office for details as to environmental matters such as the environmental compatibility of each Renesas Electronics product. Please use Renesas Electronics products in compliance with all applicable laws and regulations that regulate the inclusion or use of controlled substances, including without limitation, the EU RoHS Directive. Renesas Electronics assumes no liability for damages or losses occurring as a result of your noncompliance with applicable laws and regulations.
 11. This document may not be reproduced or duplicated, in any form, in whole or in part, without prior written consent of Renesas Electronics.
 12. Please contact a Renesas Electronics sales office if you have any questions regarding the information contained in this document or Renesas Electronics products, or if you have any other inquiries.
- (Note 1) "Renesas Electronics" as used in this document means Renesas Electronics Corporation and also includes its majority-owned subsidiaries.
(Note 2) "Renesas Electronics product(s)" means any product developed or manufactured by or for Renesas Electronics.



SALES OFFICES

<http://www.renesas.com>

Refer to "<http://www.renesas.com/>" for the latest and detailed information.

Renesas Electronics America Inc.

2880 Scott Boulevard Santa Clara, CA 95050-2554, U.S.A.
Tel: +1-408-588-6000, Fax: +1-408-588-6130

Renesas Electronics Canada Limited

1101 Nicholson Road, Newmarket, Ontario L3Y 9C3, Canada
Tel: +1-905-898-5441, Fax: +1-905-898-3220

Renesas Electronics Europe Limited

Dukes Meadow, Millboard Road, Bourne End, Buckinghamshire, SL8 5FH, U.K
Tel: +44-1628-585-100, Fax: +44-1628-585-900

Renesas Electronics Europe GmbH

Arcadiastrasse 10, 40472 Düsseldorf, Germany
Tel: +49-211-65030, Fax: +49-211-6503-1327

Renesas Electronics (China) Co., Ltd.

7th Floor, Quantum Plaza, No.27 ZhiChunLu Haidian District, Beijing 100083, P.R.China
Tel: +86-10-8235-1155, Fax: +86-10-8235-7679

Renesas Electronics (Shanghai) Co., Ltd.

Unit 204, 205, AZIA Center, No.1233 Lujiazui Ring Rd., Pudong District, Shanghai 200120, China
Tel: +86-21-5877-1818, Fax: +86-21-6887-7858 / -7898

Renesas Electronics Hong Kong Limited

Unit 1601-1613, 16/F., Tower 2, Grand Century Place, 193 Prince Edward Road West, Mongkok, Kowloon, Hong Kong
Tel: +852-2886-9318, Fax: +852 2886-9022/9044

Renesas Electronics Taiwan Co., Ltd.

7F, No. 363 Fu Shing North Road Taipei, Taiwan
Tel: +886-2-8175-9600, Fax: +886 2-8175-9670

Renesas Electronics Singapore Pte. Ltd.

1 harbourFront Avenue, #06-10, Keppel Bay Tower, Singapore 098632
Tel: +65-6213-0200, Fax: +65-6278-8001

Renesas Electronics Malaysia Sdn.Bhd.

Unit 906, Block B, Menara Amcorp, Amcorp Trade Centre, No. 18, Jln Persiaran Barat, 46050 Petaling Jaya, Selangor Darul Ehsan, Malaysia
Tel: +60-3-7955-9390, Fax: +60-3-7955-9510

Renesas Electronics Korea Co., Ltd.

11F., Samik Lavied' or Bldg., 720-2 Yeoksam-Dong, Kangnam-Ku, Seoul 135-080, Korea
Tel: +82-2-558-3737, Fax: +82-2-558-5141