

DATA SHEET

NE570/571/SA571 Comparator

Product specification

1990 Jun 7

IC17 Data Handbook

Comparator

NE570/571/SA571

DESCRIPTION

The NE570/571 is a versatile low cost dual gain control circuit in which either channel may be used as a dynamic range compressor or expander. Each channel has a full-wave rectifier to detect the average value of the signal, a linearized temperature-compensated variable gain cell, and an operational amplifier.

The NE570/571 is well suited for use in cellular radio and radio communications systems, modems, telephone, and satellite broadcast/receive audio systems.

FEATURES

- Complete compressor and expander in one IC chip
- Temperature compensated
- Greater than 110dB dynamic range
- Operates down to 6VDC
- System levels adjustable with external components
- Distortion may be trimmed out
- Dynamic noise reduction systems
- Voltage-controlled amplifier

APPLICATIONS

- Cellular radio

PIN CONFIGURATION

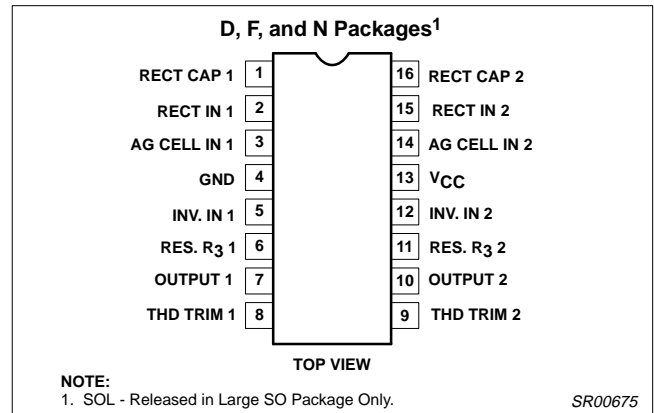

Figure 1. Pin Configuration

- Telephone trunk compandor—570
- Telephone subscriber compandor—571
- High level limiter
- Low level expander—noise gate
- Dynamic filters
- CD Player

ORDERING INFORMATION

DESCRIPTION	TEMPERATURE RANGE	ORDER CODE	DWG #
16-Pin Plastic Small Outline Large (SOL)	0 to +70°C	NE570D	SOT162-1
16-Pin Ceramic Dual In-Line Package (Cerdip)	0 to +70°C	NE570F	0582B
16-Pin Plastic Dual In-Line Package (DIP)	0 to +70°C	NE570N	SOT28-4
16-Pin Plastic Small Outline Large (SOL)	0 to +70°C	NE571D	SOT162-1
16-Pin Ceramic Dual In-Line Package (Cerdip)	0 to +70°C	NE571F	0582B
16-Pin Plastic Dual In-Line Package (DIP)	0 to +70°C	NE571N	SOT28-4
16-Pin Plastic Small Outline Large (SOL)	-40 to +85°C	SA571D	SOT162-1
16-Pin Ceramic Dual In-Line Package (Cerdip)	-40 to +85°C	SA571F	0582B
16-Pin Plastic Dual In-Line Package (DIP)	-40 to +85°C	SA571N	SOT28-4

BLOCK DIAGRAM

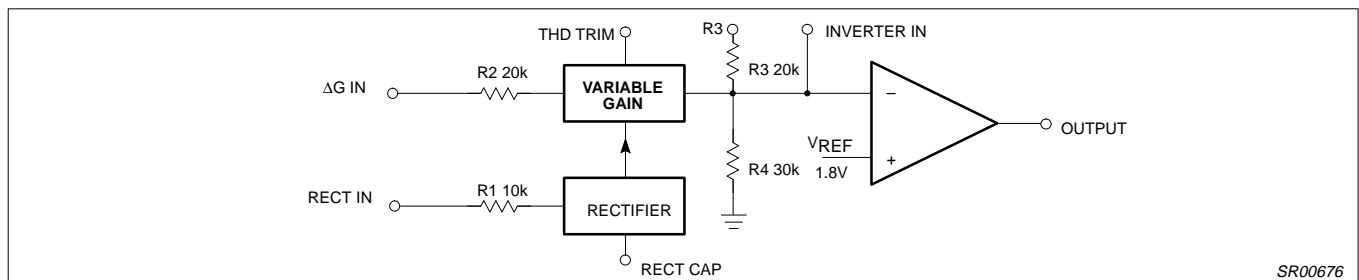

Figure 2. Block Diagram

Comparator

NE570/571/SA571

ABSOLUTE MAXIMUM RATINGS

SYMBOL	PARAMETER	RATING	UNITS
V_{CC}	Maximum operating voltage 570 571	24 18	VDC
T_A	Operating ambient temperature range NE SA	0 to 70 -40 to +85	°C
P_D	Power dissipation	400	mW

AC ELECTRICAL CHARACTERISTICS

$V_{CC} = +6V$, $T_A = 25^\circ C$; unless otherwise stated.

SYMBOL	PARAMETER	TEST CONDITIONS	LIMITS			LIMITS			UNITS
			NE570			NE/SA571 ⁵			
			MIN	TYP	MAX	MIN	TYP	MAX	
V_{CC}	Supply voltage		6		24	6		18	V
I_{CC}	Supply current	No signal		3.2	4.8		3.2	4.8	mA
I_{OUT}	Output current capability		±20			±20			mA
SR	Output slew rate			±5			±5		V/μs
	Gain cell distortion ²	Untrimmed Trimmed		0.3 0.05	1.0		0.5 0.1	2.0	%
	Resistor tolerance			±5	±15		±5	±15	%
	Internal reference voltage		1.7	1.8	1.9	1.65	1.8	1.95	V
	Output DC shift ³	Untrimmed		±20	±100		±30	±150	mV
	Expander output noise	No signal, 15Hz-20kHz ¹		20	45		20	60	μV
	Unity gain level ⁶	1kHz	-1	0	+1	-1.5	0	+1.5	dBm
	Gain change ^{2, 4}			±0.1	±0.2		±0.1		dB
	Reference drift ⁴			±5	±10		+2, -25	+20, -50	mV
	Resistor drift ⁴			+1, -0			+8, -0		%
	Tracking error (measured relative to value at unity gain) equals $[V_O - V_O(\text{unity gain})]$ dB - V_2 dBm	Rectifier input, $V_2 = +6\text{dBm}$, $V_1 = 0\text{dB}$ $V_2 = -30\text{dBm}$, $V_1 = 0\text{dB}$		+0.2 +0.2	-0.5, +1		+0.2 +0.2	-1, +1.5	dB
	Channel separation			60			60		dB

NOTES:

- Input to V_1 and V_2 grounded.
- Measured at 0dBm, 1kHz.
- Expander AC input change from no signal to 0dBm.
- Relative to value at $T_A = 25^\circ C$.
- Electrical characteristics for the SA571 only are specified over -40 to +85°C temperature range.
- 0dBm = 775mV_{RMS}.

Comparator

NE570/571/SA571

CIRCUIT DESCRIPTION

The NE570/571 comparator building blocks, as shown in the block diagram, are a full-wave rectifier, a variable gain cell, an operational amplifier and a bias system. The arrangement of these blocks in the IC result in a circuit which can perform well with few external components, yet can be adapted to many diverse applications.

The full-wave rectifier rectifies the input current which flows from the rectifier input, to an internal summing node which is biased at V_{REF} . The rectified current is averaged on an external filter capacitor tied to the C_{RECT} terminal, and the average value of the input current controls the gain of the variable gain cell. The gain will thus be proportional to the average value of the input signal for capacitively-coupled voltage inputs as shown in the following equation. Note that for capacitively-coupled inputs there is no offset voltage capable of producing a gain error. The only error will come from the bias current of the rectifier (supplied internally) which is less than $0.1\mu A$.

$$G \propto \frac{|V_{IN} - V_{REF}|_{avg}}{R_1}$$

or

$$G \propto \frac{|V_{IN}|_{avg}}{R_1}$$

The speed with which gain changes to follow changes in input signal levels is determined by the rectifier filter capacitor. A small capacitor will yield rapid response but will not fully filter low frequency signals. Any ripple on the gain control signal will modulate the signal passing through the variable gain cell. In an expander or compressor application, this would lead to third harmonic distortion, so there is a trade-off to be made between fast attack and decay times and distortion. For step changes in amplitude, the change in gain with time is shown by this equation.

$$G(t) = (G_{initial} - G_{final})e^{-t/\tau} + G_{final}; \tau = 10k \times C_{RECT}$$

The variable gain cell is a current-in, current-out device with the ratio I_{OUT}/I_{IN} controlled by the rectifier. I_{IN} is the current which flows from the ΔG input to an internal summing node biased at V_{REF} . The following equation applies for capacitively-coupled inputs. The output current, I_{OUT} , is fed to the summing node of the op amp.

$$I_{IN} = \frac{V_{IN} - V_{REF}}{R_2} = \frac{V_{IN}}{R_2}$$

A compensation scheme built into the ΔG cell compensates for temperature and cancels out odd harmonic distortion. The only distortion which remains is even harmonics, and they exist only because of internal offset voltages. The THD trim terminal provides a means for nulling the internal offsets for low distortion operation.

The operational amplifier (which is internally compensated) has the non-inverting input tied to V_{REF} and the inverting input connected to the ΔG cell output as well as brought out externally. A resistor, R_3 , is brought out from the summing node and allows compressor or expander gain to be determined only by internal components.

The output stage is capable of $\pm 20mA$ output current. This allows a $+13dBm$ ($3.5V_{RMS}$) output into a 300Ω load which, with a series resistor and proper transformer, can result in $+13dBm$ with a 600Ω output impedance.

A bandgap reference provides the reference voltage for all summing nodes, a regulated supply voltage for the rectifier and ΔG cell, and a

bias current for the ΔG cell. The low tempo of this type of reference provides very stable biasing over a wide temperature range.

The typical performance characteristics illustration shows the basic input-output transfer curve for basic compressor or expander circuits.

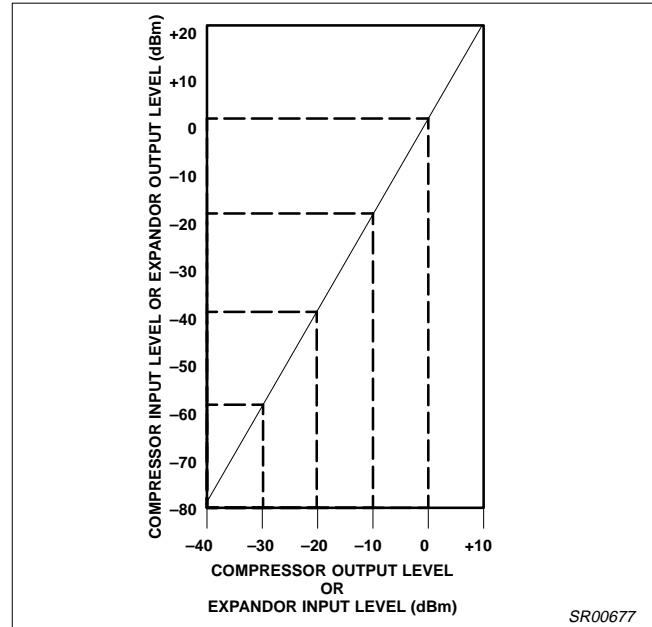

Figure 3. Basic Input-Output Transfer Curve

TYPICAL TEST CIRCUIT

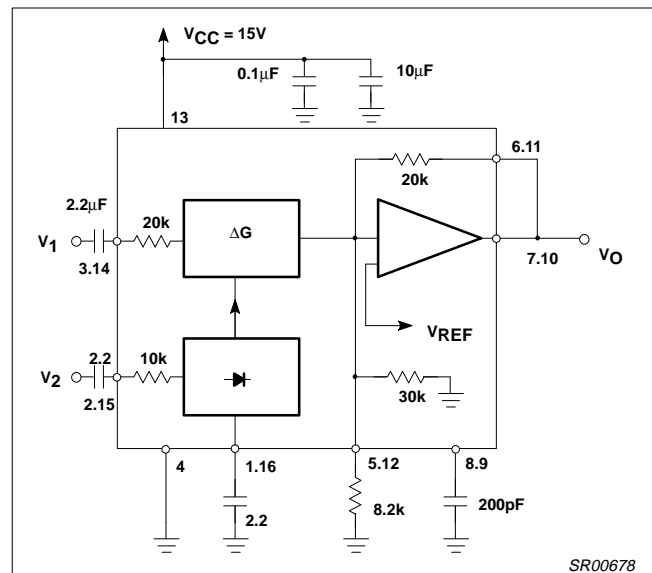

Figure 4. Typical Test Circuit

INTRODUCTION

Much interest has been expressed in high performance electronic gain control circuits. For non-critical applications, an integrated circuit operational transconductance amplifier can be used, but when high-performance is required, one has to resort to complex discrete circuitry with many expensive, well-matched components.

Comparator

NE570/571/SA571

This paper describes an inexpensive integrated circuit, the NE570 Compressor, which offers a pair of high performance gain control circuits featuring low distortion (<0.1%), high signal-to-noise ratio (90dB), and wide dynamic range (110dB).

CIRCUIT BACKGROUND

The NE570 Compressor was originally designed to satisfy the requirements of the telephone system. When several telephone channels are multiplexed onto a common line, the resulting signal-to-noise ratio is poor and companding is used to allow a wider dynamic range to be passed through the channel. Figure 5 graphically shows what a compandor can do for the signal-to-noise ratio of a restricted dynamic range channel. The input level range of +20 to -80dB is shown undergoing a 2-to-1 compression where a 2dB input level change is compressed into a 1dB output level change by the compressor. The original 100dB of dynamic range is thus compressed to a 50dB range for transmission through a restricted dynamic range channel. A complementary expansion on the receiving end restores the original signal levels and reduces the channel noise by as much as 45dB.

The significant circuits in a compressor or expander are the rectifier and the gain control element. The phone system requires a simple full-wave averaging rectifier with good accuracy, since the rectifier accuracy determines the (input) output level tracking accuracy. The gain cell determines the distortion and noise characteristics, and the phone system specifications here are very loose. These specs could have been met with a simple operational transconductance multiplier, or OTA, but the gain of an OTA is proportional to temperature and this is very undesirable. Therefore, a linearized transconductance multiplier was designed which is insensitive to temperature and offers low noise and low distortion performance. These features make the circuit useful in audio and data systems as well as in telecommunications systems.

BASIC CIRCUIT HOOK-UP AND OPERATION

Figure 6 shows the block diagram of one half of the chip, (there are two identical channels on the IC). The full-wave averaging rectifier provides a gain control current, I_G, for the variable gain (ΔG) cell. The output of the ΔG cell is a current which is fed to the summing node of the operational amplifier. Resistors are provided to establish circuit gain and set the output DC bias.

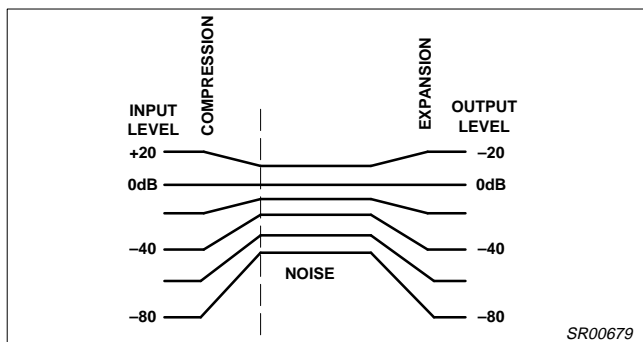

Figure 5. Restricted Dynamic Range Channel

The circuit is intended for use in single power supply systems, so the internal summing nodes must be biased at some voltage above ground. An internal band gap voltage reference provides a very stable, low noise 1.8V reference denoted V_{REF}. The non-inverting input of the op amp is tied to V_{REF} and the summing nodes of the

rectifier and ΔG cell (located at the right of R₁ and R₂) have the same potential. The THD trim pin is also at the V_{REF} potential.

Figure 7 shows how the circuit is hooked up to realize an expander. The input signal, V_{IN}, is applied to the inputs of both the rectifier and the ΔG cell. When the input signal drops by 6dB, the gain control current will drop by a factor of 2, and so the gain will drop 6dB. The output level at V_{OUT} will thus drop 12dB, giving us the desired 2-to-1 expansion.

Figure 8 shows the hook-up for a compressor. This is essentially an expander placed in the feedback loop of the op amp. The ΔG cell is setup to provide AC feedback only, so a separate DC feedback loop is provided by the two R_{DC} and C_{DC}. The values of R_{DC} will determine the DC bias at the output of the op amp. The output will bias to:

$$V_{OUT\ DC} = 1 + \frac{R_{DC1} + R_{DC2}}{R_4}$$

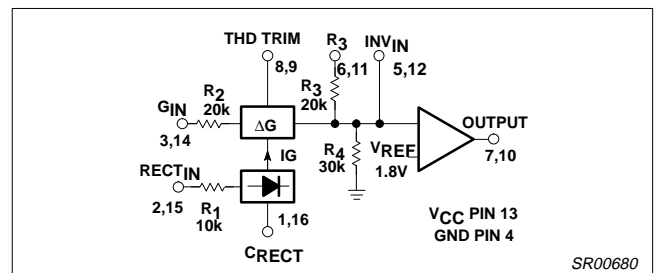

Figure 6. Chip Block Diagram (1 of 2 Channels)

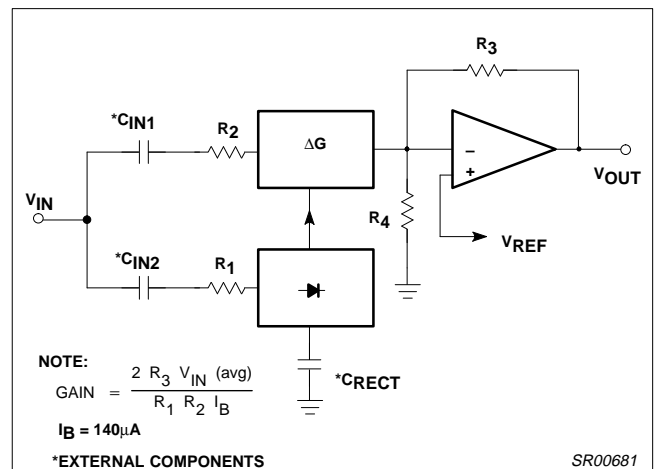

Figure 7. Basic Expander

$$V_{REF} = \left(1 + \frac{R_{DCTOT}}{30k} \right) 1.8V$$

The output of the expander will bias up to:

$$V_{OUT\ DC} = 1 + \frac{R_3}{R_4} V_{REF}$$

$$V_{REF} = \left(1 + \frac{20k}{30k} \right) 1.8V = 3.0V$$

The output will bias to 3.0V when the internal resistors are used. External resistors may be placed in series with R₃, (which will affect the gain), or in parallel with R₄ to raise the DC bias to any desired value.

Comparator

NE570/571/SA571

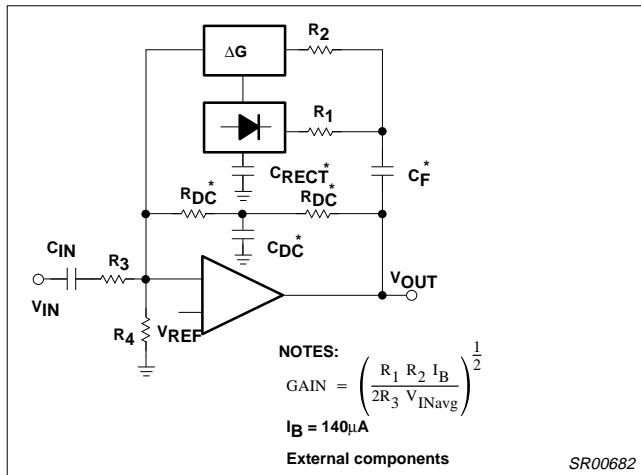

Figure 8. Basic Compressor

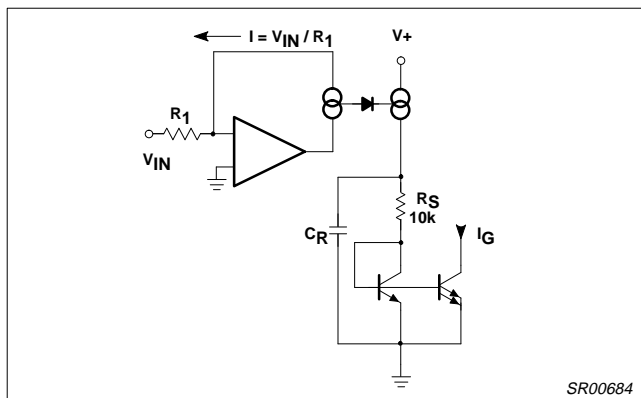

Figure 9. Rectifier Concept

CIRCUIT DETAILS—RECTIFIER

Figure 9 shows the concept behind the full-wave averaging rectifier. The input current to the summing node of the op amp, V_{IN}/R_1 , is supplied by the output of the op amp. If we can mirror the op amp output current into a unipolar current, we will have an ideal rectifier. The output current is averaged by R_5 , C_R , which set the averaging time constant, and then mirrored with a gain of 2 to become I_G , the gain control current.

Figure 10 shows the rectifier circuit in more detail. The op amp is a one-stage op amp, biased so that only one output device is on at a time. The non-inverting input, (the base of Q_1), which is shown grounded, is actually tied to the internal 1.8V V_{REF} . The inverting input is tied to the op amp output, (the emitters of Q_5 and Q_6), and the input summing resistor R_1 . The single diode between the bases of Q_5 and Q_6 assures that only one device is on at a time. To detect the output current of the op amp, we simply use the collector currents of the output devices Q_5 and Q_6 . Q_6 will conduct when the input swings positive and Q_5 conducts when the input swings negative. The collector currents will be in error by the a of Q_5 or Q_6 on negative or positive signal swings, respectively. ICs such as this

have typical NPN β s of 200 and PNP β s of 40. The a 's of 0.995 and 0.975 will produce errors of 0.5% on negative swings and 2.5% on positive swings. The 1.5% average of these errors yields a mere 0.13dB gain error.

At very low input signal levels the bias current of Q_2 , (typically 50nA), will become significant as it must be supplied by Q_5 . Another low level error can be caused by DC coupling into the rectifier. If an offset voltage exists between the V_{IN} input pin and the base of Q_2 , an error current of V_{OS}/R_1 will be generated. A mere 1mV of offset will cause an input current of 100nA which will produce twice the error of the input bias current. For highest accuracy, the rectifier should be coupled into capacitively. At high input levels the β of the PNP Q_6 will begin to suffer, and there will be an increasing error until the circuit saturates. Saturation can be avoided by limiting the current into the rectifier input to 250µA. If necessary, an external resistor may be placed in series with R_1 to limit the current to this value. Figure 11 shows the rectifier accuracy vs input level at a frequency of 1kHz.

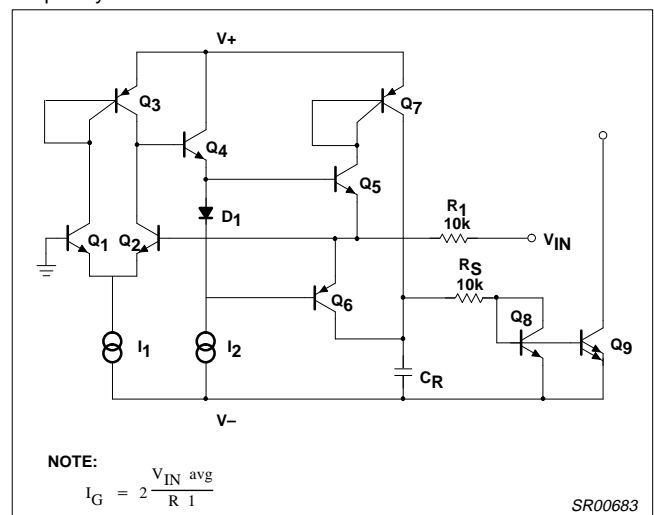

Figure 10. Simplified Rectifier Schematic

At very high frequencies, the response of the rectifier will fall off. The roll-off will be more pronounced at lower input levels due to the increasing amount of gain required to switch between Q_5 or Q_6 conducting. The rectifier frequency response for input levels of 0dBm, -20dBm, and -40dBm is shown in Figure 12. The response at all three levels is flat to well above the audio range.

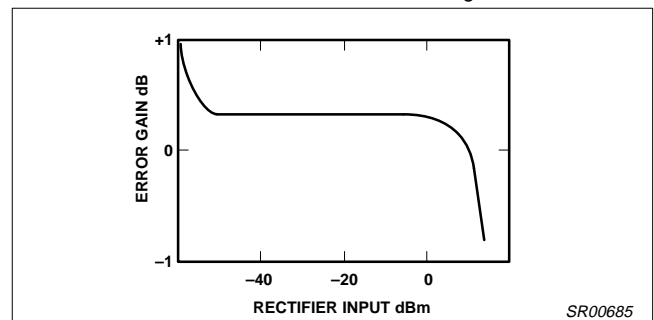

Figure 11. Rectifier Accuracy

Comparator

NE570/571/SA571

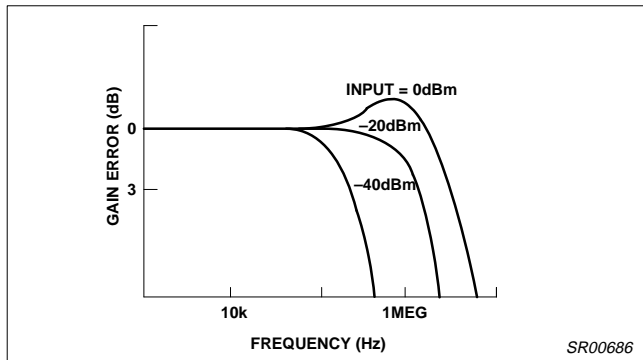

Figure 12. Rectifier Frequency Response vs Input Level

VARIABLE GAIN CELL

Figure 13 is a diagram of the variable gain cell. This is a linearized two-quadrant transconductance multiplier. Q₁, Q₂ and the op amp provide a predistorted drive signal for the gain control pair, Q₃ and Q₄. The gain is controlled by I_G and a current mirror provides the output current.

The op amp maintains the base and collector of Q₁ at ground potential (V_{REF}) by controlling the base of Q₂. The input current I_{IN} (=V_{IN}/R₂) is thus forced to flow through Q₁ along with the current I₁, so I_{C1}=I₁+I_{IN}. Since I₂ has been set at twice the value of I₁, the current through Q₂ is:

$$I_2 \cdot (I_1 + I_{IN}) = I_1 \cdot I_{IN} = I_{C2}$$

The op amp has thus forced a linear current swing between Q₁ and Q₂ by providing the proper drive to the base of Q₂. This drive signal will be linear for small signals, but very non-linear for large signals, since it is compensating for the non-linearity of the differential pair, Q₁ and Q₂, under large signal conditions.

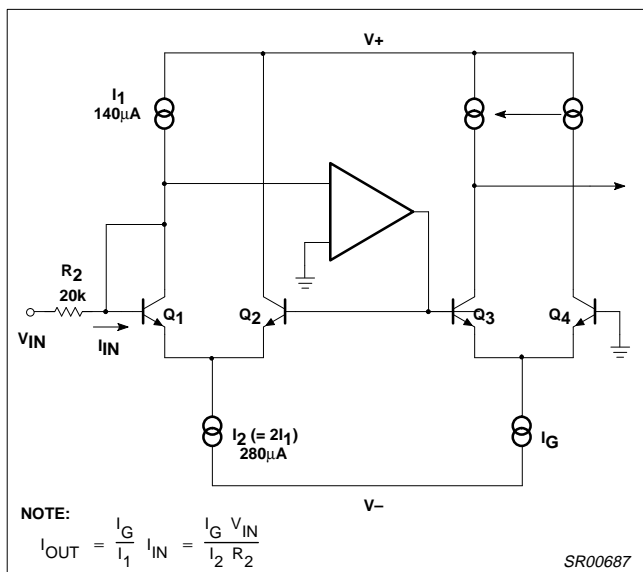

Figure 13. Simplified ΔG Cell Schematic

The key to the circuit is that this same predistorted drive signal is applied to the gain control pair, Q₃ and Q₄. When two differential pairs have the same signal applied, their collector current ratios will be identical regardless of the magnitude of the currents. This gives us:

$$\frac{I_{C1}}{I_{C2}} = \frac{I_{C4}}{I_{C3}} = \frac{I_1 + I_{IN}}{I_1 - I_{IN}}$$

plus the relationships I_G=I_{C3}+I_{C4} and I_{OUT}=I_{C4}-I_{C3} will yield the multiplier transfer function,

$$I_{OUT} = \frac{I_G}{I_1} I_{IN} = \frac{V_{IN} I_G}{R_2 I_1}$$

This equation is linear and temperature-insensitive, but it assumes ideal transistors.

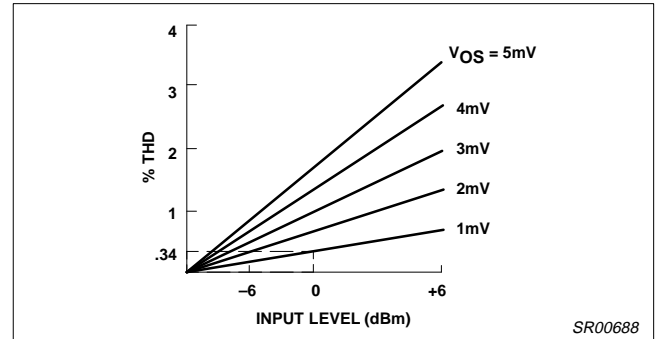

Figure 14. ΔG Cell Distortion vs Offset Voltage

If the transistors are not perfectly matched, a parabolic, non-linearity is generated, which results in second harmonic distortion. Figure 14 gives an indication of the magnitude of the distortion caused by a given input level and offset voltage. The distortion is linearly proportional to the magnitude of the offset and the input level. Saturation of the gain cell occurs at a +8dBm level. At a nominal operating level of 0dBm, a 1mV offset will yield 0.34% of second harmonic distortion. Most circuits are somewhat better than this, which means our overall offsets are typically about mV. The distortion is not affected by the magnitude of the gain control current, and it does not increase as the gain is changed. This second harmonic distortion could be eliminated by making perfect transistors, but since that would be difficult, we have had to resort to other methods. A trim pin has been provided to allow trimming of the internal offsets to zero, which effectively eliminated

second harmonic distortion. Figure 15 shows the simple trim network required.

Figure 16 shows the noise performance of the ΔG cell. The maximum output level before clipping occurs in the gain cell is plotted along with the output noise in a 20kHz bandwidth. Note that the noise drops as the gain is reduced for the first 20dB of gain reduction. At high gains, the signal to noise ratio is 90dB, and the total dynamic range from maximum signal to minimum noise is 110dB.

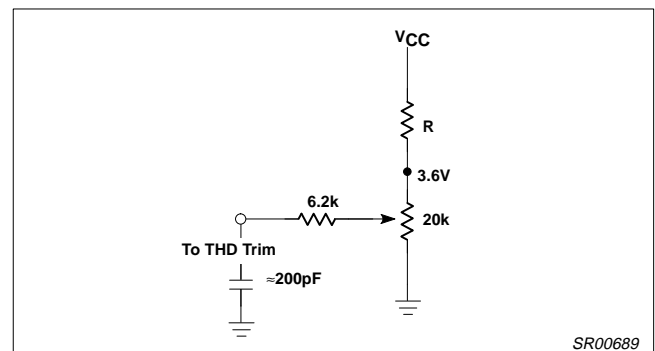

Figure 15. THD Trim Network

Comparator

NE570/571/SA571

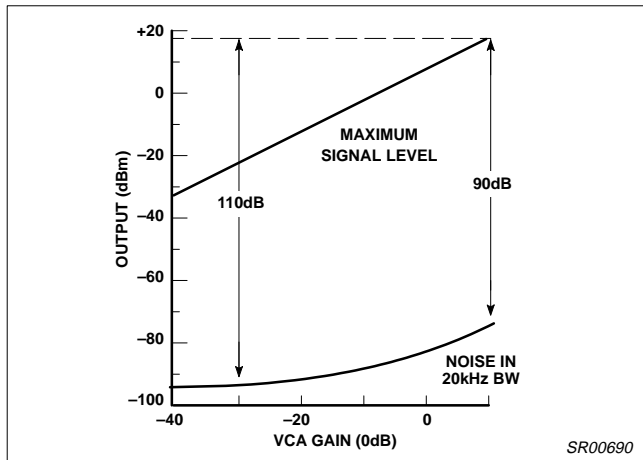

Figure 16. Dynamic Range of NE570

Control signal feedthrough is generated in the gain cell by imperfect device matching and mismatches in the current sources, I_1 and I_2 . When no input signal is present, changing I_G will cause a small output signal. The distortion trim is effective in nulling out any control signal feedthrough, but in general, the null for minimum feedthrough will be different than the null in distortion. The control signal feedthrough can be trimmed independently of distortion by tying a current source to the ΔG input pin. This effectively trims I_1 . Figure 17 shows such a trim network.

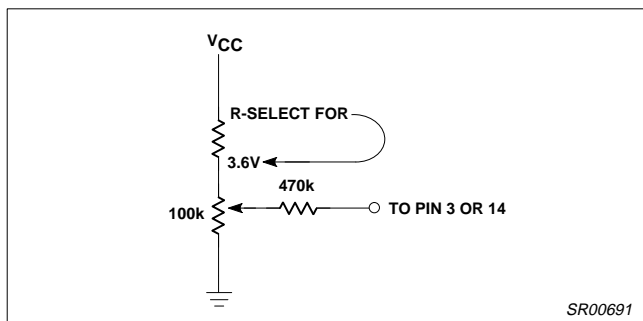

Figure 17. Control Signal Feedthrough

OPERATIONAL AMPLIFIER

The main op amp shown in the chip block diagram is equivalent to a 741 with a 1MHz bandwidth. Figure 18 shows the basic circuit. Split collectors are used in the input pair to reduce g_M , so that a small compensation capacitor of just 10pF may be used. The output stage, although capable of output currents in excess of 20mA, is biased for a low quiescent current to conserve power. When driving heavy loads, this leads to a small amount of crossover distortion.

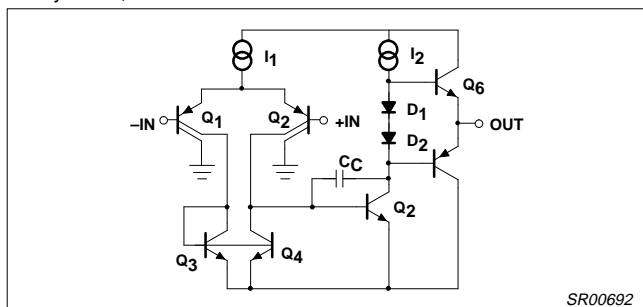

Figure 18. Operational Amplifier

RESISTORS

Inspection of the gain equations in Figures 7 and 8 will show that the basic compressor and expander circuit gains may be set entirely by resistor ratios and the internal voltage reference. Thus, any form of resistors that match well would suffice for these simple hook-ups, and absolute accuracy and temperature coefficient would be of no importance. However, as one starts to modify the gain equation with external resistors, the internal resistor accuracy and tempco become very significant. Figure 19 shows the effects of temperature on the diffused resistors which are normally used in integrated circuits, and the ion-implanted resistors which are used in this circuit. Over the critical 0°C to +70°C temperature range, there is a 10-to-1 improvement in drift from a 5% change for the diffused resistors, to a 0.5% change for the implemented resistors. The implanted resistors have another advantage in that they can be made the size of the diffused resistors due to the higher resistivity. This saves a significant amount of chip area.

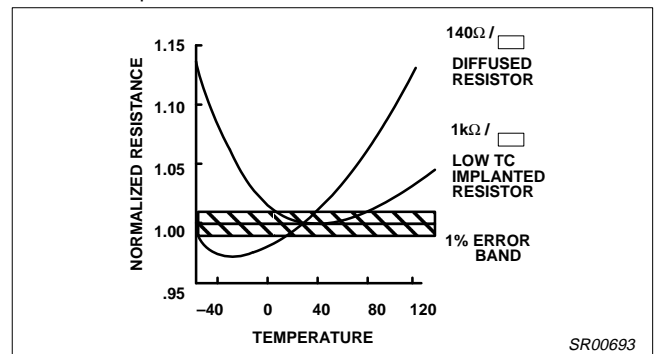

Figure 19. Resistance vs Temperature

Compandor

NE570/571/SA571

SO16: plastic small outline package; 16 leads; body width 7.5 mm

SOT162-1

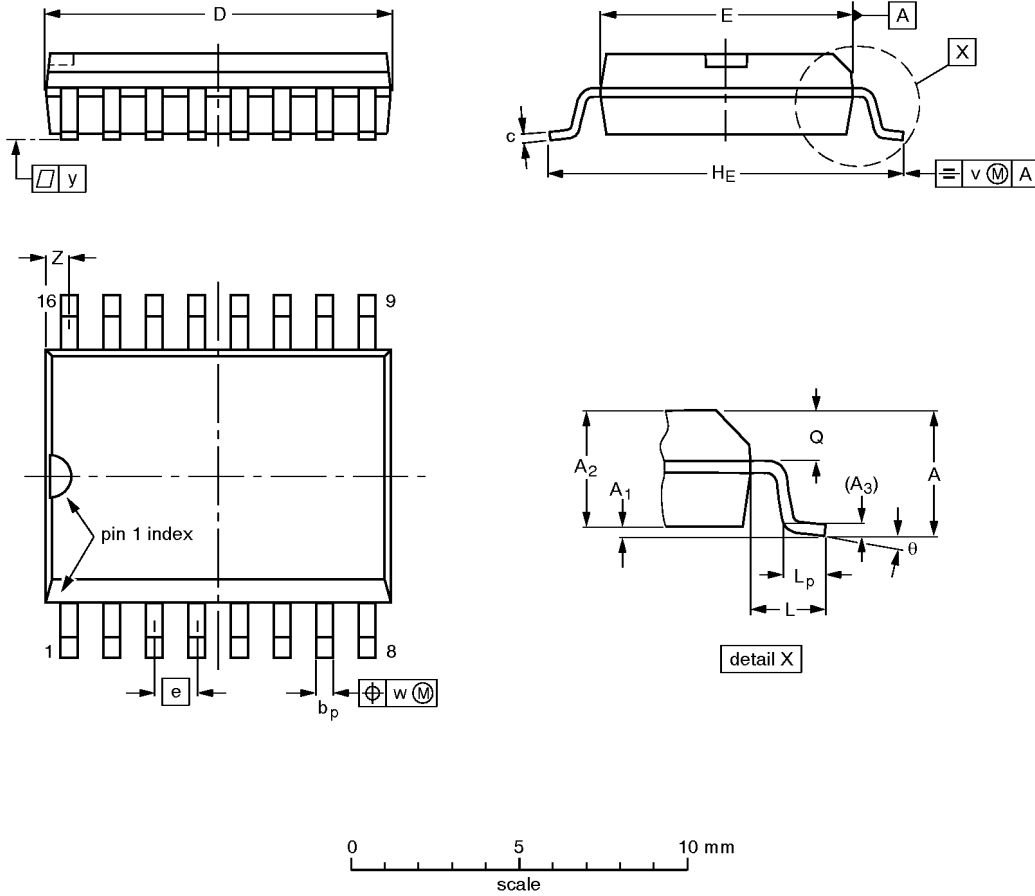

DIMENSIONS (inch dimensions are derived from the original mm dimensions)

UNIT	A max.	A ₁	A ₂	A ₃	b _p	c	D ⁽¹⁾	E ⁽¹⁾	e	H _E	L	L _p	Q	v	w	y	Z ⁽¹⁾	θ
mm	2.65	0.30 0.10	2.45 2.25	0.25	0.49 0.36	0.32 0.23	10.5 10.1	7.6 7.4	1.27	10.65 10.00	1.4	1.1 0.4	1.1 1.0	0.25	0.25	0.1	0.9 0.4	8° 0°
inches	0.10	0.012 0.004	0.096 0.089	0.01	0.019 0.014	0.013 0.009	0.41 0.40	0.30 0.29	0.050	0.42 0.39	0.055	0.043 0.016	0.043 0.039	0.01	0.01	0.004	0.035 0.016	

Note

1. Plastic or metal protrusions of 0.15 mm maximum per side are not included.

OUTLINE VERSION	REFERENCES				EUROPEAN PROJECTION	ISSUE DATE
	IEC	JEDEC	EIAJ			
SOT162-1	075E03	MS-013AA				-92-11-17 95-01-24

Compandor

NE570/571/SA571

DIP16: plastic dual in-line package; 16 leads (300 mil)

SOT38-4

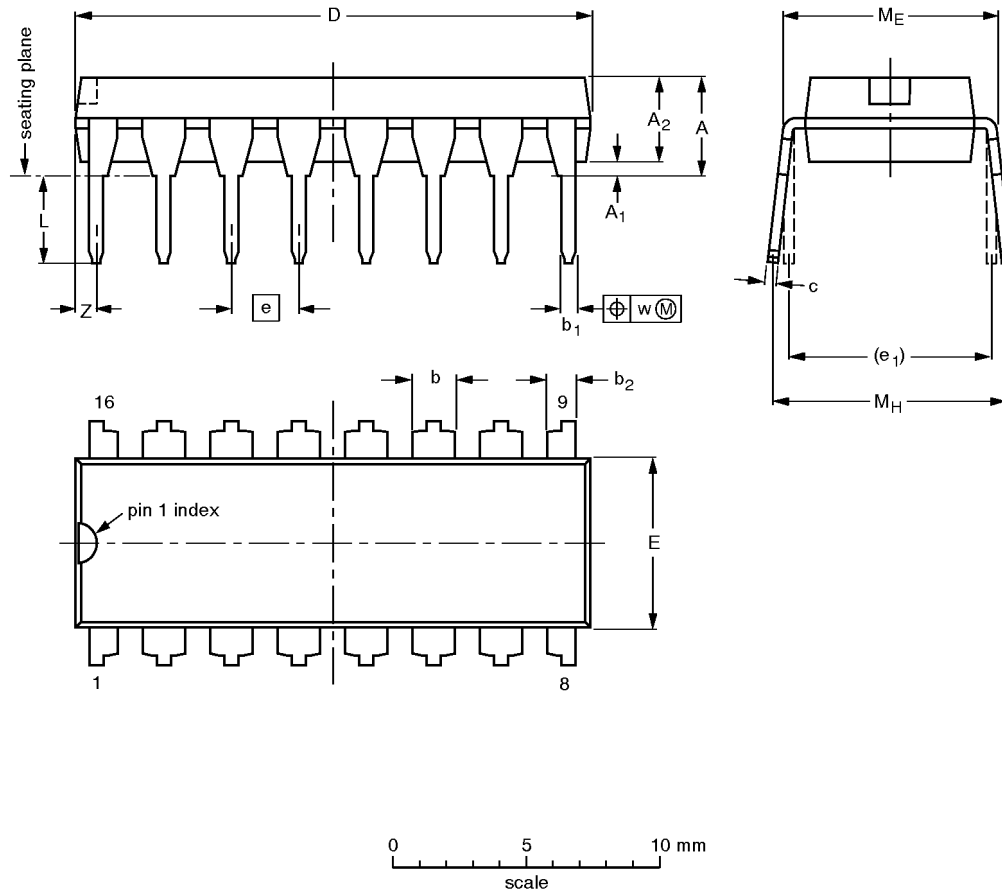

DIMENSIONS (inch dimensions are derived from the original mm dimensions)

UNIT	A max.	A ₁ min.	A ₂ max.	b	b ₁	b ₂	c	D ⁽¹⁾	E ⁽¹⁾	e	e ₁	L	M _E	M _H	w	Z ⁽¹⁾ max.
mm	4.2	0.51	3.2	1.73 1.30	0.53 0.38	1.25 0.85	0.36 0.23	19.50 18.55	6.48 6.20	2.54	7.62	3.60 3.05	8.25 7.80	10.0 8.3	0.254	0.76
inches	0.17	0.020	0.13	0.068 0.051	0.021 0.015	0.049 0.033	0.014 0.009	0.77 0.73	0.26 0.24	0.10	0.30	0.14 0.12	0.32 0.31	0.39 0.33	0.01	0.030

Note

1. Plastic or metal protrusions of 0.25 mm maximum per side are not included.

OUTLINE VERSION	REFERENCES				EUROPEAN PROJECTION	ISSUE DATE
	IEC	JEDEC	EIAJ			
SOT38-4						92-11-17 95-01-14

Comparator

NE570/571/SA571

0582B 16-PIN (300 mils wide) CERAMIC DUAL IN-LINE (F) PACKAGE

NOTES:

1. Controlling dimension: Inches. Millimeters are shown in parentheses.
2. Dimension and tolerancing per ANSI Y14. 5M-1982.
3. "T", "D", and "E" are reference datums on the body and include allowance for glass overrun and meniscus on the seal line, and lid to base mismatch.
4. These dimensions measured with the leads constrained to be perpendicular to plane T.
5. Pin numbers start with Pin #1 and continue counterclockwise to Pin #16 when viewed from the top.

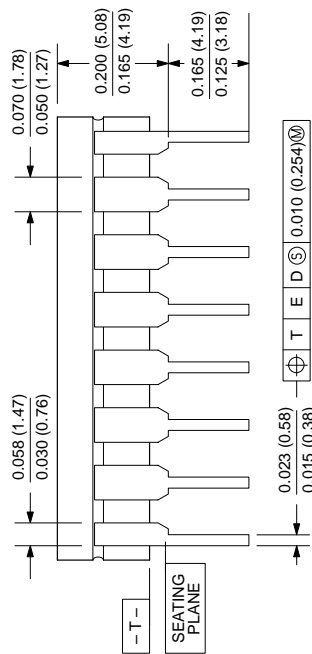
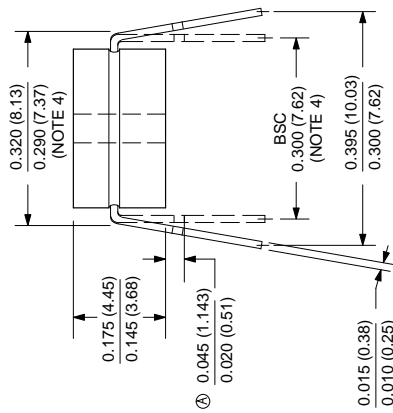
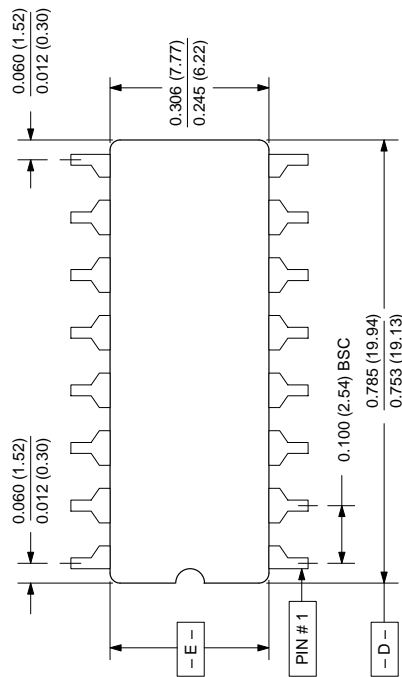

Comparator

NE570/571/SA571

DEFINITIONS

Data Sheet Identification	Product Status	Definition
<i>Objective Specification</i>	Formative or in Design	This data sheet contains the design target or goal specifications for product development. Specifications may change in any manner without notice.
<i>Preliminary Specification</i>	Preproduction Product	This data sheet contains preliminary data, and supplementary data will be published at a later date. Philips Semiconductors reserves the right to make changes at any time without notice in order to improve design and supply the best possible product.
<i>Product Specification</i>	Full Production	This data sheet contains Final Specifications. Philips Semiconductors reserves the right to make changes at any time without notice, in order to improve design and supply the best possible product.

Philips Semiconductors and Philips Electronics North America Corporation reserve the right to make changes, without notice, in the products, including circuits, standard cells, and/or software, described or contained herein in order to improve design and/or performance. Philips Semiconductors assumes no responsibility or liability for the use of any of these products, conveys no license or title under any patent, copyright, or mask work right to these products, and makes no representations or warranties that these products are free from patent, copyright, or mask work right infringement, unless otherwise specified. Applications that are described herein for any of these products are for illustrative purposes only. Philips Semiconductors makes no representation or warranty that such applications will be suitable for the specified use without further testing or modification.

LIFE SUPPORT APPLICATIONS

Philips Semiconductors and Philips Electronics North America Corporation Products are not designed for use in life support appliances, devices, or systems where malfunction of a Philips Semiconductors and Philips Electronics North America Corporation Product can reasonably be expected to result in a personal injury. Philips Semiconductors and Philips Electronics North America Corporation customers using or selling Philips Semiconductors and Philips Electronics North America Corporation Products for use in such applications do so at their own risk and agree to fully indemnify Philips Semiconductors and Philips Electronics North America Corporation for any damages resulting from such improper use or sale.

Philips Semiconductors
811 East Arques Avenue
P.O. Box 3409
Sunnyvale, California 94088-3409
Telephone 800-234-7381

Philips Semiconductors and Philips Electronics North America Corporation register eligible circuits under the Semiconductor Chip Protection Act.
 © Copyright Philips Electronics North America Corporation 1996
 All rights reserved. Printed in U.S.A.

print code

Document order number:

Let's make things better.