



# Cino XS grande PRO Cino XS grande PRO VHO

type: compact



**cafe**

espresso



INSTALLATION AND MAINTENANCE MANUAL  
Translation of the original instructions

MAN2100160 rel. 01 dated 30.01.2014

**preliminary  
safety  
information**

before using the machine, carefully read this information that helps you behave properly and guarantee a safe use; the following pages use the symbols listed here below, whose meaning is of attention:



**GENERAL;**

if the text is highlight by this symbol, it is recommended to pay special attention to the performance of the procedures described; if not carefully performed on safe conditions, they can be source of general danger;



**HIGH VOLTAGE;**

if not properly performed, the actions marked by this symbol may expose to accidental contacts with electric voltage;



**DANGEROUS TEMPERATURE;**

if not properly performed, the actions marked by this symbol may expose to accidental contacts with high-temperature parts;



**MOVING MEMBERS;**

if not properly carried out, the actions marked by this symbol may expose to accidental contacts with moving members;

the same symbols are placed inside the vending machine to indicate the parts on which to act with the utmost caution;



**SERVICE KEY IN USE;**

the symbol recommends the utmost attention during the actions described; the use of the service key intended to activate all machine functions when the door is open is only reserved to the technical operators who know the operation of the vending machine, who are aware of potential risks and who make sure they are operating on totally safe conditions;

the use of the service key shall be strictly limited to the time necessary to perform the actions requiring the use thereof; users shall be informed of the prohibition on using and approaching the vending machine;



**WEIGHT:**

the symbol reminds the user to consider the machine weight carefully for handling and placing it definitively.



**WATER SUPPLY;**

it marks the parts duly requiring caution in case of leakage, if connected with the hydraulic network;



**SUPPORT SURFACE;**

it reminds the user to install the machine on a support surface, the max. inclination of which is 2°;

**safety rules for using the vending machine**

- \*\*\* pay special attention to the chapters and notes high lit by the symbols of alert; strictly observe the rules concerning, in particular, the operators' and users' safety;
- \*\*\* the vending machine may be used by children who are at least 8 years old and by people having reduced physical, sensory or mental capacities or not having all necessary experience and knowledge, provided that they are under supervision or after they have received all necessary instructions for using the machine on safe conditions and for understanding the dangers related thereto; children must be supervised and prevented from playing with the vending machine;  
cleaning and servicing shall not be carried out by children;
- \*\*\* if you should find out a water leak or the presence of smoke, immediately detach the vending machine from the electric and hydraulic network, never try to restore its operation and apply to skilled technicians;
- \*\*\* the machine shall be installed according to national rules; pay special attention to the rules about the machines directly connected with the hydraulic network;
- \*\*\* room (during storage and operation):  
temperature: 5 °C ÷ 35 °C  
relative humidity: max 80 %
- \*\*\* the inclination of the vending machine support surface shall not exceed 2°;
- \*\*\* if the hydraulic connection tube is not supplied with the machine or in case of replacement, the connection must be carried out only with:
  - new tube;
  - of type-approved material for food use;
  - compliant with "IEC 61770 Electric appliances connected to the water mains";
  - it can support the working pressure;
- \*\*\* the user is not allowed to access the maintaining and servicing area that shall be properly signalled;
- \*\*\* never remove protections, never override safety devices and never modify the machine or its components;
- \*\*\* tools necessary to act with this vending machine:
  - a pair of scissors for electricians, a Phillips PH2 cross screwdriver for 4/6 mm self-threading screws, a set of wrenches up to 13 mm, a set of Allen wrenches from 2 to 8 mm;
  - it may be of use to procure some expendables, such as disposable paper, single-use gloves, clean cloths, cups and a bucket for the collection of waste water;
- \*\*\* never wash the machine by using water jets;
- \*\*\* for cleaning at regular intervals refer to chapter 12;

Cino XS grande PRO and PRO VHO by **rheavendors group** 



the symbol means that it is forbidden to dispose of the equipment as urban waste and compulsory to provide for separate collection in order to prevent any potential effect on the environment and human health; strictly follow the provisions of the European Parliament's 2002/96/EC Directive;



**residual risks**



a residual risk is understood as a potential danger that can not be eliminated and it persists despite all precautions in use since it is related to the intrinsic features of the product and it also includes non-identifiable risks;

the actions and behaviours listed here below are intended to reduce residual risks and you shall always adopt them when interacting with the machine;



wear clothes that can properly avoid any accident (never wear rings, chains, clothes with laces or excessively long sleeves, ...);



carefully evaluate the treatment of residues from installation (wood, plastics, ...) and utilisation (product powder, bags, ...);



never repair or carry out any technical action if you have not been properly trained;



signal that a technical action is in progress on the machine (barriers against approach, signs, ...), carry it out quickly without leaving the station;



install the machine in a sheltered, illuminated, ventilated and noiseless environment; keep it clean and never place tools or any other object on it; never install it outdoors or, anyway, never expose it to atmospheric agents;



make sure it can be neither reached by water sprays or vapours nor hit by objects that might damage it;



carefully consider the machine weight and stability during the installation and in the final working position;



supply the machine within voltage, temperature, pressure and hydraulic limits, ... as it is detailed on the following pages and provide for an effective earthing;



even if detached from supply, the machine may contain hot pressurised water at a high temperature;



never detach hydraulic and electric supplies when they are active;

# Cino XS grande PRO and PRO VHO by rheavendors group

this manual is intended to describe the **Cino XS grande** vending machine in its two versions **PRO** and **PRO VHO**; by using the same basic components, the two machines differ from each other in components and in the features specified later on; the descriptions supplied by this document are shared by all two versions, if not otherwise specified by the text or by the icons typical of every single model.



**Cino XS grande PRO**



**Cino XS grande PRO VHO**

cover upper rail	yes	no
visible coffee beans canister	no	yes
coffee beans canister sensor	no	yes
pressurized boiler	400 cc; 1.500 W;	800 cc; 2.000 W;
static relay	no	yes

01	30.01.2014	supplement EN60335 5th edition and declaration of conformity;	A4
00	05.11.2013	First issue;	
rel.	date	description	
this document is made available electronically on site <a href="http://www.rheavendors.com">www.rheavendors.com</a>			

**general guarantee conditions**

these conditions regulate Rheavendors Industries S.p.A.'s obligations with reference to guarantee and repair; any other term or condition, either verbal or written, is not applicable, including those in the purchaser's purchase orders, if not explicitly accepted and signed by Rheavendors Industries S.p.A.; if the guarantee terms here below should be held not to be valid and/or lawful in the Country where the product is sold, they will not be effective whereas all the other clauses will remain valid and applicable;

- 1st the mechanical and electronic components of the machine are guaranteed for twelve months, starting from the sales date certified by the fiscal receipt;
- 2nd the guarantee shall be understood as the free replacement or repair of any part of the machine that – at the manufacturer's unquestionable discretion – should prove to be originally defective due to manufacturing defects; the cost of sending the manufacturer machines, defective pieces and spare parts will be totally charged to the user's account; the manufacturer reserves the right to use new or reconditioned components for repair; if replaced, original components will be guaranteed for 12 months; the parts replaced under guarantee will become the property of Rheavendors Services S.p.A. (request for "Form PO 19.01/2b" Materials under guarantee – Authorisation to return);
- 3rd in case of irreparable failure or if a failure of the same origin is repeated, the manufacturer may – at its unquestionable discretion – replace the machine with another one, the model of which is either the same or an equivalent one; the guarantee of the new machine will be extended up to the original term of guarantee of the replaced machine;
- 4th all the parts that should prove to be defective due to negligence or carelessness (non-observance of the instructions for the operation of the machine), incorrect installation or maintenance by unauthorised personnel, transport damage or any circumstance – anyway – not due to the manufacturing defects of the machine are not covered by guarantee; the installation and connection with supply plants as well as the maintenance operations mentioned by the installation manual are also excluded from any performance under guarantee; the guarantee will not cover payment systems either; whether installed on the machine or supplied as an accessory, they are subject to their manufacturer's guarantee whereas Rheavendors Industries S.p.A. will just act as a broker; all changes made to the machine and not agreed with the manufacturer in writing will involve the immediate termination of the guarantee period and anyway fall under the Customer's total responsibility;
- 5th the guarantee is excluded in all cases of improper use of the machine;
- 6th Rheavendors Industries S.p.A. will disclaim all responsibility for any damage that may be directly or indirectly caused to people, animals or things as a result of:  
improper use of the vending machine; incorrect installation;  
improper energy or water supply; serious maintenance deficiency;  
actions or changes not explicitly authorised; use of non original spare parts;
- in case of failure, Rheavendors Industries S.p.A. is obliged neither to compensate any economic damage due a forced stop of the machine nor to extend the guarantee period;
- 7th if the machine should be transferred to a centre designated by the manufacturer for overhaul or repair, the relative transportation risks and costs will be charged to the user's account; the freight charges of machines, defective pieces and spare parts are always understood as charged to the user's account;

**declaration of conformity**

Rheavendors Industries S.p.A. declares that this drink vending machine has been designed and manufactured in compliance with the following directives and safety standards:

**Directives:**

2004/108/EC; 2006/42/EC; 97/23/EC; 2011/65/EC (RoHS); 2002/96/EC (RAEE);

**Regulations:**

1907/2006/EC (REACH); 1935/2004/EC;

**Standards:**

**SAFETY:**

EN 60335-1: 2012  
EN 60335-2-75: 2004 + A1: 2005 + A11: 2006 + A2: 2008 + A12: 2010;

**EMC:**

EN 55014-1: 2006 + A1: 2009 + A2:2011;  
EN 55014-2: 1997 + A1: 2001 + A2: 2008;  
EN 61000-3-2: 2006 + A1: 2009 + A2: 2009;  
EN 61000-3-3: 2008;

**EMF:**

EN 62233: 2008;

manufacturer

Rhea Vendors Group S.p.A.  
Via Valleggio, 2/bis – 22100 Como – (CO) - Italia

factory of the machine

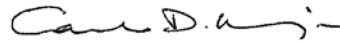

Rheavendors Industries S.p.A.  
Via Garavaglia, 58 - 21042 Caronno Pertusella – (VA) – Italy

The Legal Representative



(C. D. Majer )

**marking**

conformity	quality
	

**ISO 9001 certification**





table of contents

01.	legend	page 10
02.	introduction	page 10
03.	technical data	page 11
04.	configurations	page 13
05.	presentation	page 15
06.	preliminary actions	page 23
07.	connections	page 24
08.	installation and first power on	page 25
09.	programming	page 28
10.	parameters	page 41
11.	solution of problems	page 44
12.	maintenance	page 47
13.	how to do to...	page 51
14.	hydraulic diagram	page 54

in the listed chapters, the manual describes a

**Cino XS grande PRO and PRO VHO**

vending machine in its hardware and software components for a complete and fully-aware use of all machine functions; due to the large variety of available options and the constant technical update of our vending machines, some special device or function might be indicated and described not in the manner you expect; in this case, do not hesitate to contact us;

telephone: 0039 02 966 551  
fax: 0039 02 96 55 086  
e mail: [rheavendors@rheavendors.com](mailto:rheavendors@rheavendors.com)



**ATTENTION:** this label applied next to the serial number label inside the vending machine points out that the instructions supplied by this manual must be carefully read before the installation and operation of the vending machine;









please, print this manual only if necessary; environmental protection is our common interest;

## 01. legend

some general instructions that may be of use for reference to this manual;

### 01.01. abbreviations and pictograms

- E = dispensing cycle of drinks based on instant products and coffee beans;
- R = machines with external water supply;
-  = mixer for mixing the instant product with water;
- VSF = worm screw pitch in the product canister;
-  = product shaker of instant canisters;
-  = espresso coffee brewer
-  = hot water dispenser
-  = maximum operating pressure of the boiler;
-  = water supply pressure range of the vending machine;

## 02. introduction

### 02.01. copyright information

© Rheavendors Industries S.p.A.; all rights reserved;  
 this document contains some confidential information of Rheavendors Industries S.p.A.'s exclusive property; the content of this document can be neither disclosed in favour of third parties, nor copied or reproduced in any form whatsoever, either fully or partially, without Rheavendors Industries S.p.A.'s prior authorisation in writing; the utilisation, reproduction or disclosure of the technical information in this document can be protected by Rheavendors Industries S.p.A. according to the Law;

this manual is intended for the owner of the vending machine; it is an integral part of the machine and it shall be kept with it;

the information supplied by this manual are intended to achieve the best performances of the vending machine within the scope of application established by the Manufacturer; Rheavendors Industries S.p.A. reserves the right to improve future production without serving any prior notice and without assuming any obligation to update the products on the market; the manufacturer will disclaim all responsibility for any inaccuracy due to misprints;

### 02.02. contacts

**Rheavendors Services S.p.A.** is at disposal for any kind of support and information on this vending machine;

telephone: + 39 02 966 551  
 fax: +39 02 96 55 086  
 e mail: rheavendors@rheavendors.com

for any reference about our partners all over the world please visit site : [www.rheavendors.com](http://www.rheavendors.com)

### 02.03. serial number labels

to be able to identify the vending machine rapidly and univocally as well as to get the best support, please specify the data of the serial number label;

**rheavendors group**   
 made by: Rheavendors Industries S.p.A.  
 via Caravaggio 58 Caronno Varesino - 21018 - ITALIA  
 type: COMPACT Made in Italy  
**CINO XS GRANDE PRO** Class I  
**E 4 R VHO** 1,0MPa  
 230V 50/60Hz 2100W 1,0,1,0,8MPa  
   
 D00000X000000-s/n 2014 00 00000

code : D12345A67890  
 s/n: 1234 56 7890 (example)

silvery serial number labels are applied inside and outside the case of the machine;



## 03. technical data

### 03.01. dimensions

PRO	height (including upper rail of 28 mm):	618 mm
VHO	height (including visible coffee beans canister of 80 mm):	670 mm
	width:	420 mm
	depth:	563 mm
	depth with open door:	880 mm

### 03.02. mass

PRO	33 kg
VHO	34 kg



**values and indications for standard machine  
anyway refer to serial number label data**

### 03.03. supply

water	- connection by means of a solenoid valve with 3/8" gas male face; - supply by a submersible pump:	from 0.1 MPa to 0.8 MPa 24 V dc, 1.2 A max.;
energy	- 230 V, 50 Hz; single-phase and ground; - cable of the following type: H05VV-F 3G 1 mm <sup>2</sup> 300/500 V	PRO: 1,600 W; VHO: 2,100 W

### 03.04. sound pressure

A-weighted sound pressure level; less than 70 dB(A)

### 03.05. keyboard

ten selection buttons;

### 03.06. display

multicolor; work area 66.5 mm x 33.2 mm; resolution 64 x 128 pixel;

### 03.07. dispensing cpt.

open; folding cup support: (useful height 85 mm); maximum 150 mm

### 03.08. drip tray

drip tray beneath the cup surface: capacity 750 ml

### 03.09. dispenser

a fixed dispensing place;

### 03.10. safety

water	overflow sensor and pressure relief valve; water inlet solenoid valve with anti-flood sensor;	
energy	a main switch, a door switch; two 6.3x32 mm fuses;	230 V ac; 12 A delayed
heat	manually resettable sensors;	127 °C
software	time limits for water dispensing cycles;	

### 03.11. grinder motor

230 V dc; 150 W

### 03.12. grinders

conical: 400 r.p.m.

### 03.13. espresso brewer

variable-volume brewing chamber;  
motor: Ø 45 mm; 8 ÷ 15 gr.  
24 V dc; 30 W

### 03.14. air break

air break with overflow and level switch;

### 03.15. pump

vibration; 230 V ac

### 03.16. product motors

max. four, according to the machine configuration; 95 r.p.m. 24 V dc

### 03.17. mixing bowls

max. two, according to the machine configuration;

### 03.18. mixer motors

max. two, according to the machine configuration; 15,000 r.p.m. 24 V dc

### 03.19. product sensor

only in VHO machines, one; installed to control the coffee beans canister content; capacitive; plastic canister;

### 03.20. boiler

pressure boiler;	PRO	0.4 litres, 1,500 W
	VHO	0.8 litres, 2,000 W
		maximum 1,0 MPa

## 03.21. product canisters

max. four instant , according to the machine configuration; single (55 mm) or double (110 mm) width; dispensing worm screws 9 mm or 18 mm in pitch; with mixer gear and stirrer, if arranged by the configuration and with standard or shorter product slide outlet (see 05.22.);

- instant canister capacity:

width 55 mm capacity 1.7 litres	
coffee	0.33 kg
milk	0.38 kg
chocolate	0.94 kg
tea	0.98 kg
sugar	1.20 kg

width 110 mm capacity 3.5 litres	
milk	0.80 kg
chocolate	2.20 kg

- coffee beans canister (or hopper) capacity:

PRO: 1.0 kg  
VHO: 2.0 kg

## 03.22. relay

solid state relay to supply the pressure boiler heating element;

VHO

## 03.23. miscellaneous

machine parameters programmable by means of a flash key or selection keyboard; NRI G13 or similar payment system compartment; protocols: serial, parallel, executive, MDB; data collection by means of a flash key (see 09.06.);

## 03.24. notes

the water and energy supply tolerance limits that can ensure a good and proper operation of the **Cino XS grande PRO and PRO VHO** machine are:

water:

- total hardness:
- recommended conductivity:

from 10 °f to 25 °f (\*)  
400 µS @ 20 °C

(\*) if harder, please use anti-limestone filters;

energy:

- nominal voltage:

+10 % /- 15 %

room (during storage and operation):

- temperature:
- relative humidity:

5 °C ÷ 35 °C  
max 80 %

electric consumption:

- power (vending phase):

PRO da 13 Wh a 380 Wh  
VHO da 44 Wh a 396 Wh

the complete data according to the EVA-EMP Energy Measurement Protocol, are made available upon request (see 02.02.);



**the power supply cable supplied with the vending machine shall not be altered under any circumstance; in case of loss or damage replace it by using an original component only;**

make sure that the electric installation can deliver the power suitable for the machine (see 03.03.);

a good ground connection is not only a legal obligation for the protection of users and operators, but it can also provide for correct power supply;

**04. configurations**

04.01.

Cino XS grande PRO and PRO VHO configurations are numerous; they are coded by means of some categories exemplified here below in the abbreviation of the machine:

a. product canisters

number of instant products and coffee beans:

Cino XS grande PRO E/4;

b. water supply

external, by means of the inlet solenoid valve:

Cino XS grande PRO E/4 R

c. numbering

product canisters, mixing bowls and mixers are numbered in progression, from the left to the right, as it is shown later on; this numbering is used in the chapter on how to programme (see 09.) drinks;

04.02. examples of configurations

V.M. Cino XS grande PRO E/4 R

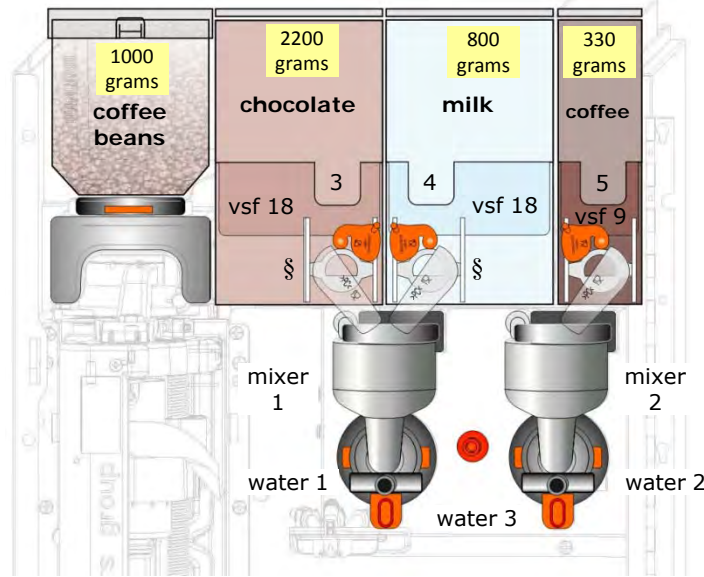

keyboard selections

1. espresso
2. black coffee
3. white coffee
4. cappuccino
5. latte macchiato
6. moccaccino
7. chocolate
8. choko-milk
9. instant coffee
10. hot water

V.M. Cino XS grande PRO E/5 R

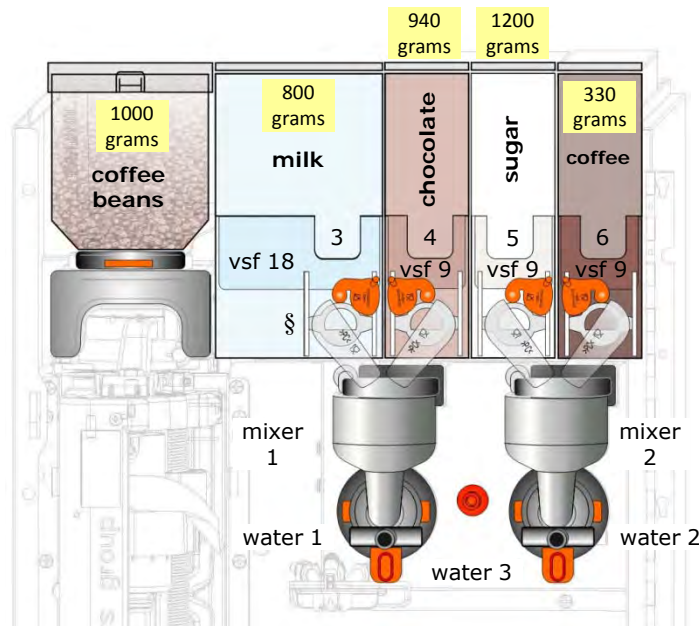

keyboard selections

1. preselection sugar
2. espresso
3. espresso with milk
4. long
5. capp-ciocc
6. cappuccino
7. white coffee
8. latte macchiato
9. moccaccino
10. chocolate

V.M. Cino XS grande PRO VHO E/4 R

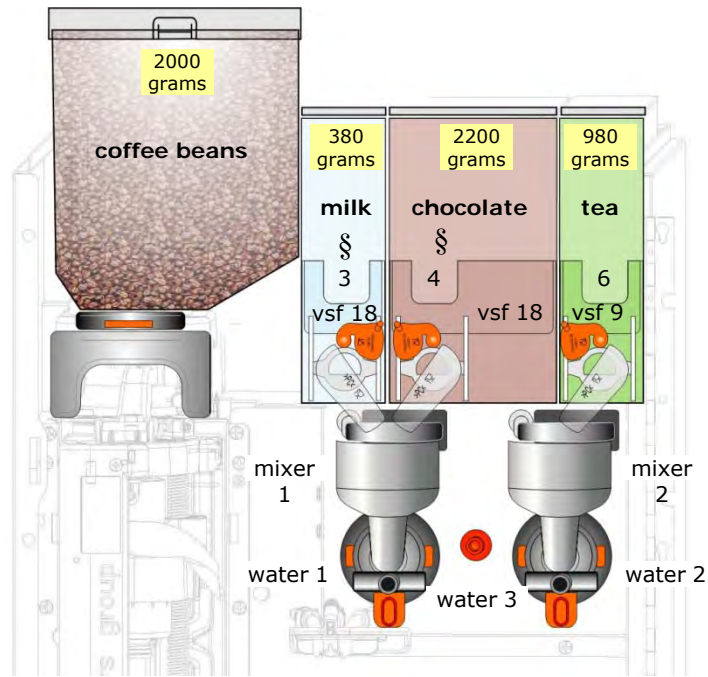

keyboard selections

1. espresso short
2. espresso
3. espresso long
4. latte macchiato
5. americano
6. cappuccino
7. moccacino
8. choko-milk
9. tea
10. hot water

V.M. Cino XS grande PRO VHO E/3 R

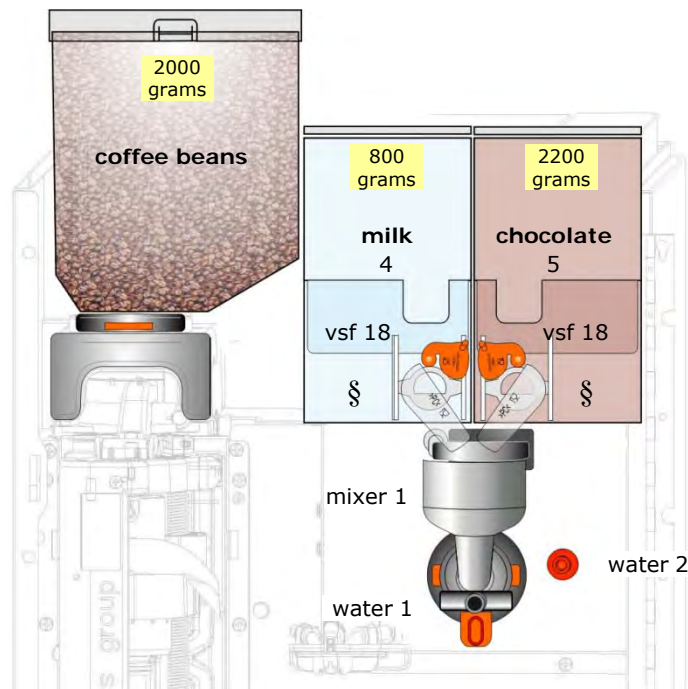

keyboard selections

1. espresso short
2. espresso
3. espresso long
4. latte macchiato
5. americano
6. cappuccino
7. moccacino
8. Choko-milk
9. milk
10. hot water

the configurations above are just some of possible **Cino XS grande PRO and PRO VHO** configurations, considering the vending machine releases and programmability; the principles of operation and information are anyway universal and applicable to all machines of the **Cino XS grande PRO and PRO VHO** range;

04.03. accessories

to complete and supplement the vending machines of the **Cino XS grande PRO and PRO VHO** range, Rheavendors Industries S.p.A. has got a series of accessories manufactured for these machines, such as cabinets, autonomous water supply kits, payment systems, external drawer to collect the exhaust grounded coffee connection with machines intended to dispense cold drinks, ... ;

Rheavendors Services S.p.A. is at disposal for any kind of support and information on special configurations (see 02.02.);

05.  
presentation

**CINO XS GRANDE PRO**

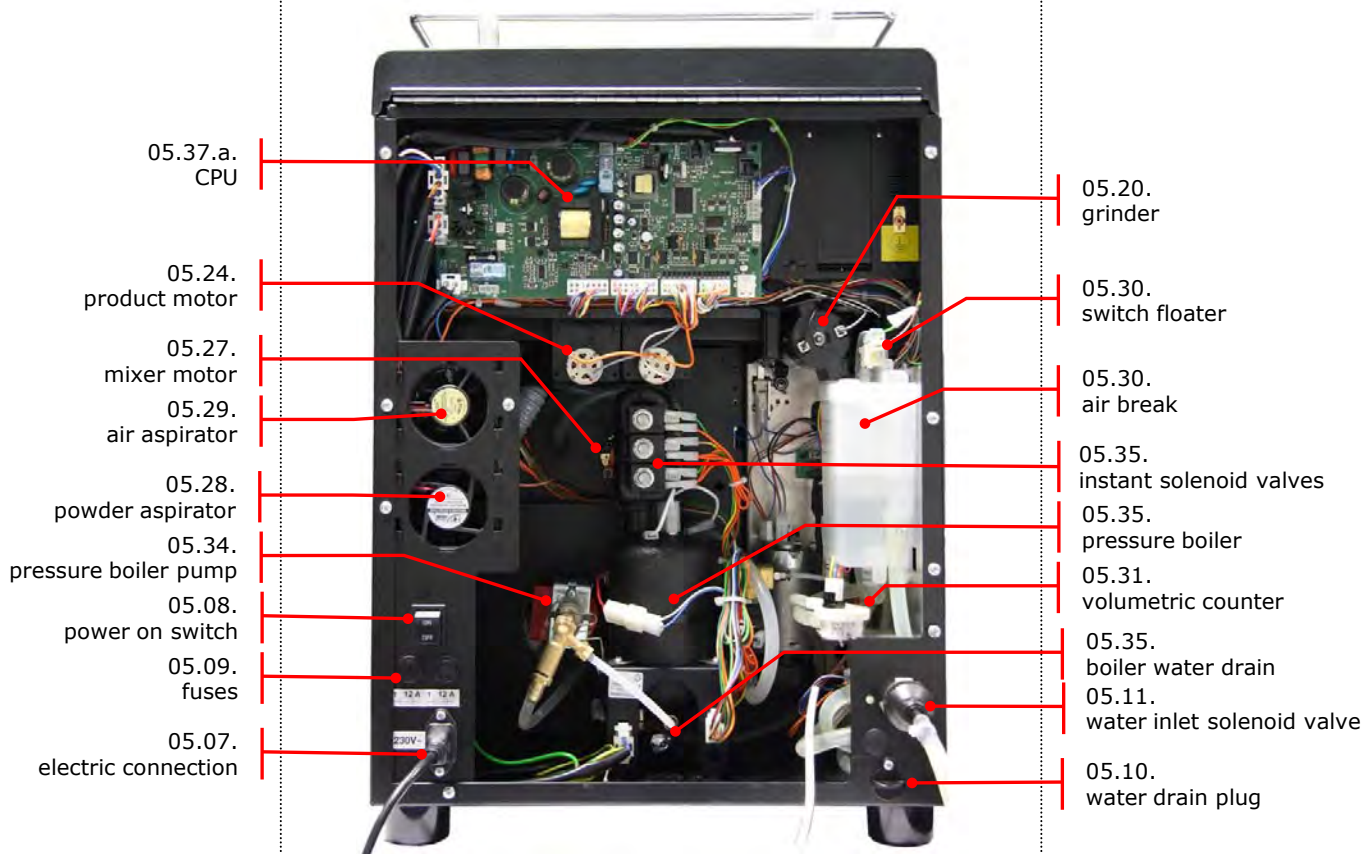

**CINO XS GRANDE PRO VHO**

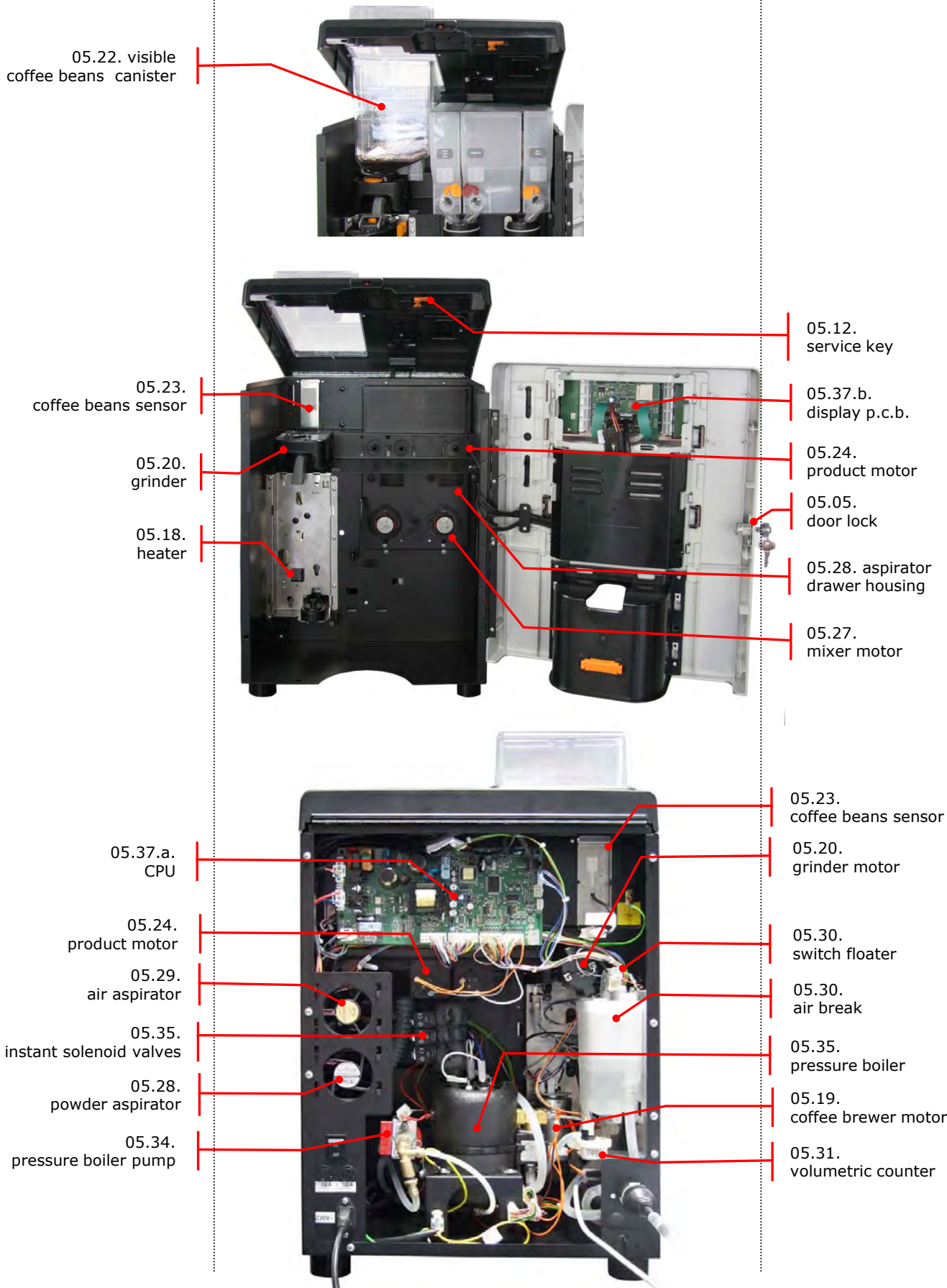



# Cino XS grande PRO and PRO VHO by rheavendors group

05.01. general information

the Rhea Cino XS grande PRO and PRO VHO vending machine is a machine explicitly designed for being easily used by all users since no specific competence is required in preparing drinks;

the function consists in dispensing drinks by mixing food products and water at a proper temperature; the correct operation of the vending machine occurs in closed rooms in normal environmental conditions and at a room temperature between 5 °C and 35°C, the relative humidity below 80%;



**use only specific ingredients for vending machines;**

dispense by briefly pressing a key of the selection keyboard (see 05.02.); make sure that the cup has been properly positioned at the dispensing station, if necessary by using the flap support for caps (see 03.07.);

05.02. selection keyboard

after having closed the door, press the buttons to dispense; the button will turn on during the dispensing cycle; keys will assume various functions in the programming mode (see 09.) and enable the user to modify the machine parameters; keys are numbered progressively from the top: 1, 2, ... and from the left;

05.03. display

the display messages inform users and operators about the operation state of the vending machine;

05.04. dispenser

the Cino XS grande PRO and PRO VHO vending machine has got a fixed drink dispenser on the cup support surface;

05.05. door lock

the door is closed by means of a lock; the key is mapped and numbered for identification;

05.06. drip tray

it collects possible residual drops from the dispenser and, if necessary, the waste water in excess from three-way valve; it is slided at the bottom of the machine case, in the front, and it is composed by a covering drawer and a grilled cover that can be washed by running water; an electric contact is intended to control the filling level (see 11. and 13.03.);



05.07. electric connection

a three-terminal socket is arranged at the back of the case for the connection of the mains cable;

05.08. power on switch

to power on and off the machine;

05.09. fuses

installed on the mains power supply (see 03.10.); fuses must be necessarily replaced by specialised technical personnel only;

05.10. water drain plug

from where to let the silicone tube from the air break come out for emptying;

05.11. water inlet solenoid valve

the water inlet solenoid valve has got an anti-flood safety device intended to stop the water inlet in case of failures; to its electrical pins can be connected in parallel an any submersible pump (see 03.03.);



05.12. door switch

to power off the machine when the door is open;



**attention**  
some parts remain anyway network-connected  
act extremely carefully;

use the service key to supply the vending machine if it is necessary to activate the machine when the door is open; the key is housed in the cover;



# Cino XS grande PRO and PRO VHO by rheavendors group

- 05.13. internal button (PROG)      the button giving access to the machine programming mode is arranged on the orange protection carter inside the door (PROG);
- 05.14. flash key housing      programming flash keys are arranged in the carter inside the door (see 09.06.);
- 05.15. label pockets      product labels are arranged inside the door panel, beneath the orange carter; insert the labels into the pockets by observing the machine configuration (see 13.02.);
- 05.16. coffee brewer      after receiving the coffee dose from the grinder and compressing it, percolation occurs in the coffee brewer with the water from the pump; the used dose is conveyed towards the slide and the drawer at the bottom of the machine; the structure of the brewer is kept at the correct temperature by a hot air heating system programmable via software (see 09.01.e.);
- 05.17. brewer presence switch      the coffee brewer presence is controlled by a micro-switch that can inhibit the selections including coffee beans, if it is not present;
- 05.18. coffee brewer heater      a safety cover is intended not only to protect the operator against moving parts, but also to keep the coffee brewer at the correct temperature through an air heater preserving the drink quality even after a long vending machine pause;
- 05.19. coffee brewer motor      the variable coffee brewer motor is intended to regulate the chamber closing and compressing phases in order to compress ground coffee for its percolation; its action is controlled by an encoder that informs the CPU on the brewer position;
- 05.20. grinder      it grinds the coffee beans in the canister to pour it in the coffee brewer chamber; the grinding degree can be manually adjusted by means of the wheel you can access after removing the coffee canister whereas the ground quantity is determined by a software parameter (see 09.01.a "grinder time") that establishes the grinder work time;
- 05.21. grounds container      it collects over sixty ground doses after having used them in the coffee brewer; a software option (see 09.01.o.) will show a warning message as soon as the tray is full;
- 05.22. product canisters      instant product canisters dispense their content in the underlying mixing bowls; an internal worm screw driven by the product motor will push the instant product to the product slide; they can be equipped with a wheel and a product shaker for constant dispensing; the outlet, the dimension of which can be either standard or smaller, has got a closing baffle; the coffee beans canister (hopper) has got a closing orange blade that is to be inserted before lifting the canister; canisters are closed by a cover to protect products;
- 05.23. product sensor coffee beans      only in VHO, a product sensor intended to check the quantity of coffee beans in the canister is arranged behind the coffee beans canister; if the product is lacking, it signals it through the vending machine display;
- 05.24. product motors      they are intended to rotate the worm screws inside instant product canisters to pour the product quantity necessary for selection in the mixing bowls;

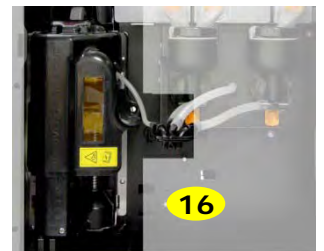
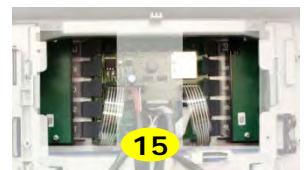

05.25. mixing bowls  
 the mixing bowls of the mixers will accommodate the instant products you have poured to mix them with water; the fan of mixer motors will act at the bottom and the drink outflow to the dispenser occurs by means of a silicone tube; mixing bowls and outlet tubes can be washed with lukewarm running water;



05.26. nozzle support  
 a fixed support on the cup station is intended to accommodate the three dispensers coming from the mixing trays of mixers and the direct hot water;



05.27. mixer motor  
 the motors of mixers help you mix instant products with water by means of the rotation of the fan mounted on their axis; the rotation speed can be adjusted (see 09.01.a.) to the features of the various products;



05.28. powder aspirator  
 an aspirator will eject suspended product residuals from the vending machine; the aspirator is connected with a drawer beneath product slides to intercept the residual impalpable powder coming from selections; the action time of the aspirator is programmable by means of a software parameter (see 09.01.f.); aspirated air is ejected through the slots of the rear panel;

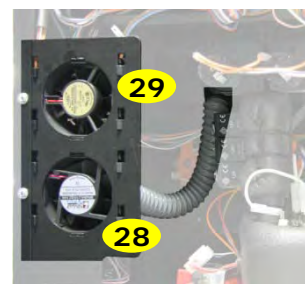

05.29. air aspirator  
 to aspirate the air from the internal environment of the machine to avoid any condensate;

05.30. air break  
 it accumulates water for sending to the pressure boiler; the level is controlled by a float and – if above the established level – it will flow back to the inlet solenoid valve safety device, thus preventing the inlet of new water;



05.31. volumetric counter  
 it supplies the CPU the water quantity running through the coffee brewer to establish its volume; the water quantity of instant selections is established by the time set in the "water N" parameter only (see 09.01.a.);

- 05.32. door lighting
- the door panel is lit up by two led modules mounted inside ("a");
  - the side panels are lit up by two led modules mounted inside ("b");
  - the cup station and the logo are lit up by a module mounted inside ("c");
  - the product labels and selection keys are lit up by two modules ("d") mounted at the back of the door;

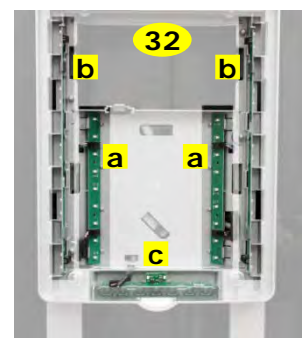

05.33. coin box  
 in some versions, the components intended to support the payment system (not supplied) are arranged inside the door; the coin box is complete with a lock and the flat cable of the payment system is inserted into a 10 pin J4 connector of the display board;



# Cino XS grande PRO and PRO VHO by rheavendors group

05.34. pressure boiler pump



a vibration pump with by pass, directs the water to the solenoid valves and the three ways for the espresso circuit;;

**attention**

these components may be very hot even if the machine is off;

05.35. pressure boiler

pressure boiler complete with a temperature probe and protection clicscons; the drain tap may be used to empty the hydraulic circuit (vedi 09.01.f.);

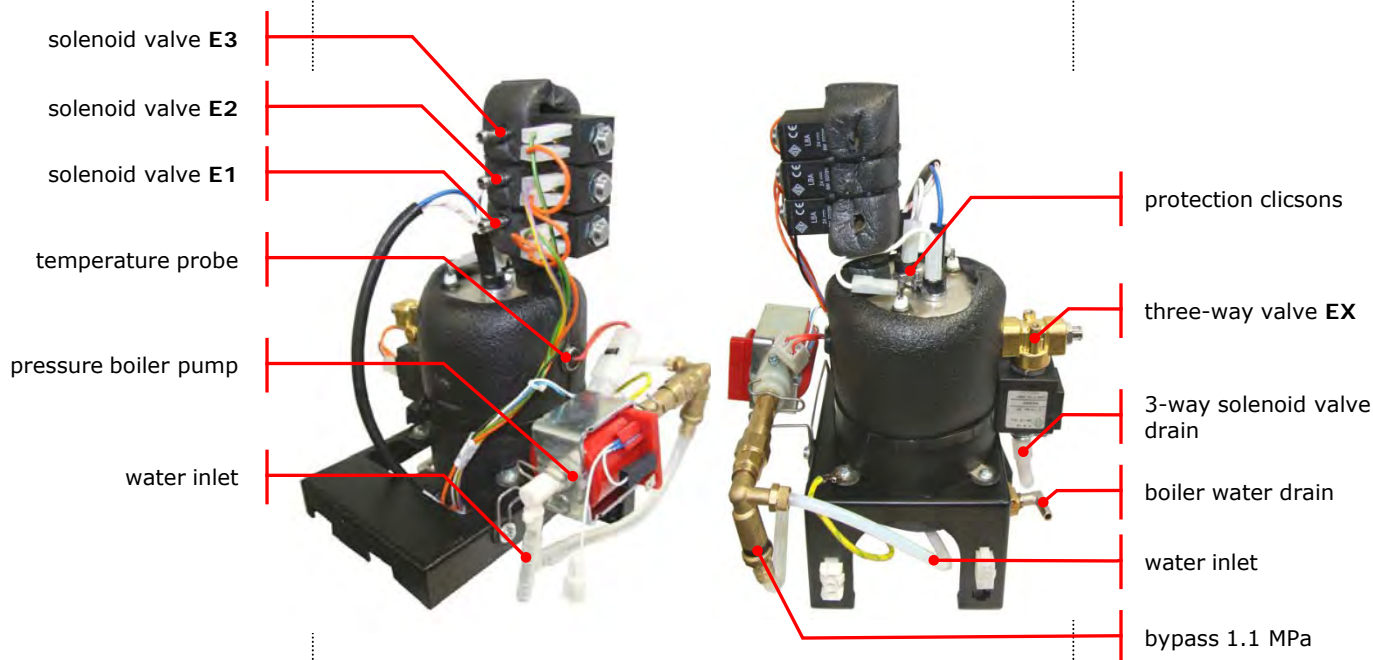

solenoid valve	name sw	outlet
E1	water 1	mixing bowl 1
E2	water 2	mixing bowl 2
E3	water 3	hot water 3
EX	coffee water	coffee brewer

the water quantity of instant selections is established by the time set in the "water N" parameter (see 09.01.a.);

05.36. static relay

only in "WHO" machines, the solid state relay arranged inside the vending machine behind the supply block can directly supply the pressure boiler heating element so as not to overload the power supply board;



# Cino XS grande PRO and PRO VHO by rheavendors group

## 05.37. electronics

### 05.37.a. CPU

- DL5 - pressured boiler heating element led
- pressured boiler heating element
- IN 230 V ac
- DL4 - led pump
- grinder motor 2A fuse
- grinder motor connector
- DL1 - led 24 V dc

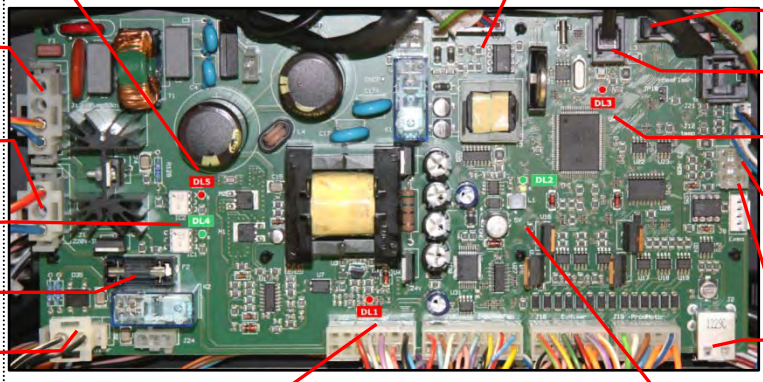

- temperature probe connector
- display board connector
- RFID connector
- DL3 - led 5 V CPU
- MDB payment system connector
- executive payment system connector
- USB port
- DL2 - led 5 V dc

the CPU board is intended to govern the machine operation. It is the place of location of machine programs and it is secured to the frame by means of four board supports; the phone cable is intended to connect the box for the flash key (see 05.14. and 05.37.c.) whereas the display cable will transmit the signal exchange with the keyboard and the display arranged in the door (see 05.02. and 05.03.); the temperature probe cable is separated from the machine wiring to avoid hampering the removal of the probe; the boiler led will turn on whenever you activate the boiler heating element;

the five leds display the machine state;

name	color	description
DL1	red	+ 24 V universal
DL2	green	+ 5 V power supply
DL3	red	+ 5 V microprocessor
DL4	green	espresso pump
DL5	red	pressured boiler heating element

### 05.37.b. display p.c.b.

the display board secured inside the door will accommodate the signals of the selection keyboard and display the messages; a flat cable will connect it with the CPU; the internal programming button is installed on the printed circuit of this board;



- labels lighting
- to the keyboard
- to the CPU
- door lighting

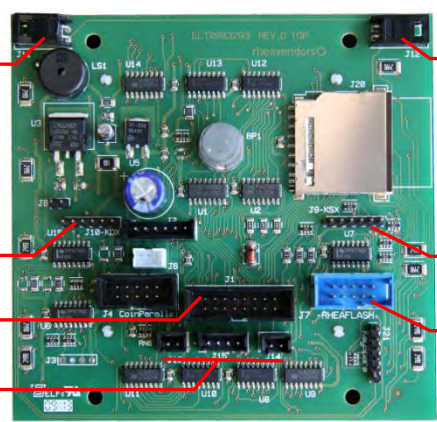

- labels lighting
- to the keyboard
- to the flash board

### 05.37.c. flash board

arranged inside the door, beneath the orange carter (see 05.14.), it enables the user to insert the flash key to programme the machine (see 09.06.);

05.38. software

the software installed in in **Cino XS grande PRO and PRO VHO** can be subdivided into two different chapters called:

- master:  
it is the software determining the machine cycles, the links between the functions, the order of execution of operations; this software can not be modified by the operator, but it can be replaced in the CPU by means of a flash key written at works or by means of rheAction (see 09.06. and 05.39.);
- configuration:  
it is the software determining the times and the succession of dispensing drinks, the payment system protocol, the display modes, ...; variables may be modified by the operator either manually aboard the machine or by means of rheAction (see 09.06. and 05.39.) to adapt the machine behaviour to the final users' needs (product quantities and mixtures, warning messages ...) (see 09.);

if it is necessary to update one of the software programmes above on the machine, the flash key may be of great use; the key can contain either software or both of them and provide for a rapid and safe transfer;

please note that the flash key used for these software handlings must have been previously initialised (with rheAction for example);

in general, the transfer procedure is:

- power off the machine;
- insert the flash key or into the connector of the board in question (see 05.14. and 05.37.);
- power on the machine by means of the service key (see 05.12.);
- wait for the message on the machine display;
- answer the messages on the display;
- power off the machine and remove the flash key;

please note: if the flash key should contain a master software, the transfer will certainly occur from the key to the machine, whereas it will be necessary to follow the steps described by 09.06 in case of a configuration software;



05.39. rheAction

a system called rheAction is intended to complete and supplement the programming executable in the machine; it is composed by a software and hardware, installable in a pc, capable of storing, modifying and writing the configuration data of Rhea machines; Rheavendors Services S.p.A. is at disposal for any kind of support and information on the rheAction system (see 02.02.);

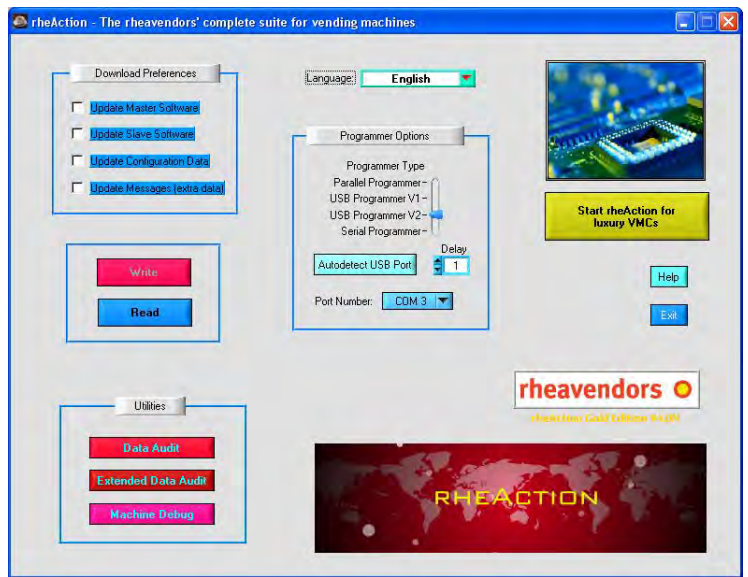

## 06. preliminary actions

### 06.01. handling



the vending machine may be transported, handled and positioned by skilled and trained personnel only; while handling, never overturn the machine; observe the orientation arrows on the package;

#### **attention**

handle the machine carefully to prevent the authorised personnel from being injured; considering the weight and overall dimensions of the vending machine, it is recommended to use a truck at low speed;



### 06.02. unpacking

- approach the packed vending machine to its work position;
- cut the two plastic belts;
- lift the external package;
- remove the drip tray;
- extract the protection bag up;
- lift the vending machine and arrange it on the work surface;

#### **attention**

the materials composing the package shall never be left within the reach of people from outside, in particular of children, because they represent a potential source of danger; only specialised companies may be charged to provide for the disposal of package components;



### 06.03. positioning

the vending machine shall be arranged for work in a sheltered room by using a support suitable for the weight of the machine (see 03.02.); its distance from the walls shall provide for good air circulation and easy access;

any inclination of the surface shall not exceed 2°;

it is recommended to arrange an easily cleanable impermeable protection beneath the vending machine to collect any accidental product fall;



### 06.04. preparation

when the machine is in its final working position:

- cut the clamp securing the door key to the liquid recovery tray gridded cover;
- insert it into the lock (see 05.05.), rotate it and open the door;
- remove the envelope of documents and labels;
- take the power supply cable and the water union; the water union can be used for water connection with the network;
- screw the four feet to the lower case corners by adjusting them for proper inclination;
- lift the machine cover and remove the guards intended to fasten product containers for transport;
- insert the labels by observing the order of selections determined by the machine configuration (see 04.02.);

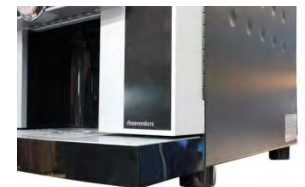

**07.**  
**connections**

07.01. water

make sure that the water used to supply the vending machine has all proper features for human consumption;

make sure that there is no sign of impurity and check the degree of hardness; if necessary, contact an analysis lab;

if necessary, use a softening filter and replace the cartridge at regular intervals, in observance of the manufacturer's instructions, to preserve the machine components;

make sure that the network pressure is the one preset for the machine (see 03.03.); use a pump or a reducer in case of non-compliance; it is recommended to install a tap to detach the machine from the network; connection shall occur by means of:

- new tube;
- of type-approved material for food use;
- compliant with "IEC 61770 Electric appliances connected to the water mains";
- it can support the working pressure;

if the tube is not supplied with the machine or in case of replacement use tubes featured as above only;

for the drinkability features of "waters intended for human consumption" refer to the following Internet address:

[http://eur-lex.europa.eu/  
directive 98/83/EC of 03/11/1998](http://eur-lex.europa.eu/directive_98/83/EC_of_03/11/1998)

07.02. energy

observe the rules on connections with the electric network, in particular on grounding; connect the machine permanently without using any reduction, adaptor, multiple socket or extension; use the network connection cable supplied with the vending machine only; it is recommended to install a switch detaching the machine from the network;

it is recommended to install a differential current device operating below 30 mA, detaching the machine from the mains and promptly tripping in case of improper electric input in order to considerably reduce the risks arising out of any short-circuit;

**attention**

check the power plant capacity to supply the power required by the machine (see 03.03) and the observance of the rules in force; strictly refer to the data of the serial number label (see 02.03.)

insert the cable into the connection socket (see 05.07.); then, connect the plug with the socket and supply the vending machine;

for a correct and safe configuration of the electric power supply installation refer to the following Internet address, if necessary:

[http://eur-lex.europa.eu/  
directive 2006/95/EC of 12/12/2006](http://eur-lex.europa.eu/directive_2006/95/EC_of_12/12/2006)





**08. installation and first power on**

08.01. introduction

after having unpacked the vending machine, arranged it firmly in the work place and connected hydraulically and electrically, carry out some actions to operate it;

**wash hands thoroughly with water and soap before handling the machine and the products; only use potable water to clean the components;**



no coffee beans

08.02. activity



open the door, lift the cover, power on the main switch of the machine (see 05.08.);

pour a small quantity of coffee beans into the coffee hopper to avoid displaying the no coffee message; remember to open the hopper orange blade;

**attention**

arrange a cup beneath the nozzles, insert and rotate the service key into the door switch (see 05.12.);



**attention**

the vending machine is supplied and running to all effects; the mobile parts of the coffee brewer will be handled; act extremely carefully;

at the end of assembly and final testing, the water used for testing is discharged from the machine; at the first power-on at the station, all circuits must be filled in before any other action; for this reason, the machine will automatically load water;

the vending machine executes a diagnostic cycle for loading and heating waters; the warning messages for the progress of these phases appear on the display;

make sure that the machine is hydraulically supplied and that the drip tray is inserted; while following the display messages, press "4" to carry out the first installation;

the display shows:

wait for water to come out of the product nozzles for some seconds; the flow will automatically stop after dispensing all necessary water and the display will show:

the pressure boiler water starts heating to achieve the temperature setpoint (see 09.01.e.);

at the end of this phase, ca. 3 minutes later, the display will show the standby messages:

INSTALLATION

Water OK ?  
10= START

driptray  
inside? 10= START

first install.  
starts automat.

switching on.....  
please wait

refilling water  
wait

end installation  
autom. reset

wait  
temperature

Cino XS  
ESPRESSO

place your  
cup

## 08.03. washing



transportation, storage and installation conditions can not provide for immediate utilisation of the vending machine and it is recommended to perform a complete wash cycle before using the vending machine;

press the programming button (see 05.13.);  
the display shows alternatively the messages:

### attention

the vending machine is supplied and running to all effects; the mobile parts of the coffee brewer will be handled; act extremely carefully;

arrange a cup beneath the nozzles; the machine will dispense a pre-fixed water quantity for each wash cycle;

press "4" to enable the wash cycle of the water circuit (boiler, tubes, mixing bowls, ...);

follow the display instructions that require the operator to must be sure that the drip tray is empty and the machine is hydraulically connected;

the display shows:

key "1=pb" will dispense water through the coffee brewer; selections "2=mx1", "3=mx2" will do it in the two mixing bowls for instant products; key "4=water" in the hot water outlet hole to the cup; key "8=pb A." will carry out the sanitary wash cycle for the brewer and then the wash cycles for the mixing bowls and the direct water circuit; (see 09.04.);

repeat the operation for some times to rinse the whole water circuit of the machine; during the wash cycles, the display will show the circuit that is being washed;

a special wash cycle is intended to sanitise the coffee brewer by using specific cleaning products in tabs; press key "8=pb A.", the display shows:

after having positioned the cup beneath the dispensing nozzles, put a tab in the coffee brewer chamber; press "10", follow the display instruction and wait for the wash cycle to automatically come to an end;

### attention

ca. 100 cc. water will be dispensed for each one of the six wash cycles;

at the end of the sanitary wash cycle of the coffee brewer, the machine will also wash the mixing bowls and the direct water circuits; for this reason, make sure that at least a couple of cups can be placed beneath the product nozzles;

power off the vending machine by means of the service key; arrange it in its support (see 05.12.); power off the main switch at the back of the machine (see 05.08.);

1= PROGRAMMING  
3= TEST VEND

2= DATA 4= CLEAN  
5= MAINTENANCE

Water OK ?  
10= START

driptray  
inside? 10= START

CLEANING  
butt.: 1=pb 2=mx1  
3=mx2 4=water  
8=pb A.

Cleaning  
Brewer

or

Cleaning  
mixer "N"

or

Cleaning  
water

CLEANING  
butt.: 1=pb 2=mx1  
3=mx2 4=water  
8=pb A.

put pastille and  
push P10=START

Soaking  
4:30min 1:15min

cleaning brewer  
6 mal 1/6

08.04.

prepare a chlorine-based anti-bacterial sanitising solution by observing the instructions supplied with the product; remove and immerse the following into the solution: the product canisters you have disassembled, the trays of mixers, their fans and the silicone tubes intended to dispense products; the time necessary to sanitise is specified by the anti-bacterial product package; at the end, remove all the parts you have sanitised from the solution, dry them carefully by using clean cloths and reassemble them into the machine; rotate the baffles of the product slides of instant canisters to close them and load the canisters with reference to the machine configuration (see 04.) and to the canister labels; fill in the coffee hopper with coffee beans; close the canisters and the coffee hopper with their upper covers; rotate the baffles of the product slides (see 05.22.) to open them and pull the orange blade intended to close the coffee hopper; (see also 12.);

to clean and treat food products properly, refer to the content of the following Internet address:

[http://eur-lex.europa.eu/  
regulation 2004/852/EC of 29/04/2004](http://eur-lex.europa.eu/regulation/2004/852/EC_of_29/04/2004)

lower down the cover and close the door by means of the lock key (see 05.05.) and place it in a safe place;

08.05

power on the machine by means of the main switch; the display will show in sequence following messages:

till the water temperature of the pressure boiler is suitable for the value set in the memory (by default);

at the end of this phase intended to heat water in the pressure boiler, the vending machine is ready to dispense on a free basis and the display will alternatively show some stand-by messages:

Cino XS  
ESPRESSO

switching on...  
please wait

wait  
temperature

Cino XS  
ESPRESSO

place your  
cup

**09. programming**



the vending machine is programmed by means of parameters considered standard for the specific configuration required; values forming the composition of recipes – written in the board memories – enable the user to dispense drinks without requiring the installer to set up special programmes; to modify these parameters to adapt the drinks you have produced, refer to the following; at the end of the chapter (see 09.07.), a summary table may help the user trace back all the programming items; to access the programming mode, open the front door of the machine and use the service key in the safety switch;

**attention**

the vending machine is supplied and running to all effects in this mode of operation; act extremely carefully;

access the programming mode

press the "PROG" key (see 05.13.); the display shows alternatively the messages:

1 = PROGRAMMING  
3 = TEST VEND

- "1" to access the programming mode of machine variables;
- "2" to display the drink quantities you have dispensed;
- "3" to dispense on a free basis;
- "4" to dispense water to wash the water circuits;
- "5" to schedule maintenance operations;

2 = DATA 4 = CLEAN  
5 = MAINTENANCE

quit the programming mode

after having programmed, press "1" and then the key "PROG" to go back to the usual operation of the vending machine and to store all changes you have made; the display will show:

END PROGRAMMING  
wait .....

09.01. "prog"

press the key "PROG", press "1"; the buttons of the selection keyboard will assume the following functions:

1 = PROG.

Key 1	to scroll the items forward
Key 6	to scroll the items backward

Key 2	to scroll the variables of items forward
Key 3	to scroll the variables of items backward

Key 4	to increase the value of the variable on the screen
Key 5	to decrease the value of the variable on the screen

the items are (scroll by means of key "1"):

- 09.01.a. key 1 contains the variable composing selection 1;
- ... ..
- key 10 contains the variables composing selection 10;
- 09.01.b. prices to establish the prices of every single dispensing cycle;
- 09.01.c. happy price to establish the prices of every single dispensing cycle produced in special time bands;
- 09.01.d. coins to determine the values of coins;
- 09.01.e. temperatures to set up the boiler water temperatures;
- 09.01.f. miscellaneous to programme different options;
- 09.01.g. diagnostics to display some machine parameters;
- 09.01.h. sales audit to display the quantity of dispensing cycles you have performed

PROGRAMMING  
BUTTON N

PROGRAMMING  
PRICES

PROGRAMMING  
HAPPY PRICE

PROGRAMMING  
COINS

PROGRAMMING  
TEMPERATURE













PROGRAMMING  
MISCELLANEOUS















DIAGNOSTICS

SALES AUDIT

09.01.i. MDB	it contains the programming of the MDB protocol parameters;	PROGRAMMING MDB
09.01.l. clock	to set up the machine clock;	PROGRAMMING CLOCK
09.01.m. out of service	to record any failure that may have occurred;	REGISTRATION OUT OF SERVICE
09.01.n. product qty	to check and enable product dispensing cycles;	PROGRAMMING PRODUCT QTY
09.01.o. maintenance	it contains the maintenance control parameters of the machine;	PROGRAMMING MAINTENANCE
09.01.p. RFID CARD	to determine the RFID card parameters;	PROGRAMMING RFID CARD
09.01.q. tuning motors	to regulate the time of product motors and the grinder motor;	TUNING MOTORS
09.01.r. calibration product flux	programming of the product quantities delivered per unit of time;	CALIBRATION PRODUCT FLUX
09.01.s. product audit flux	products delivery data;	PRODUCT AUDIT FLUX
09.01.t. id. machine	it contains the machine identification parameters;	PROGRAMMING ID MACHINE
09.01.u. variflex brewer	coffee brewer programming;	PROGRAMMING VARIFLEX BREWER
09.01.a. button from 1 to 10	<p>press key "2" when the display shows "key n" to scroll the variables composing the function of that key (by pressing keys "4" and "5");</p> <ul style="list-style-type: none"> <li>- if you press "2" when "FUNCTIONING", the key will perform the function you have programmed (dispensing cycle of a drink); see paragraph "functioning";</li> <li>- if you press "2" when "INHIBITED", the key will be inhibited and it will perform no function;</li> <li>- if you press "2" when "PRESELECTION", the key you have pressed before the real selection will fulfil the function of the items listed in the "preselection" paragraph (scroll by pressing key "4" and "5");</li> </ul>	<p>FUNCTIONING</p> <p>INHIBITED</p> <p>PRESELECTION</p>
"functioning"	<p>use key "2" to scroll the following items:</p> <p>choose the "extended" option to display all variables and the "reduced" option to display only the parameters, the values of which are other than zero (use keys "4" and "5" to change the option);</p> <p>espresso coffee is the first product you can programme for each selection key; there are two variables:</p> <ul style="list-style-type: none"> <li>- the water quantity in the cup; change it by means of "4" and "5"; if the variable is zero, no espresso will be dispensed (drink composed by instant products only);</li> <li>- coffee will be dispensed before (value 1) or after (value 0) instant products;</li> <li>- to allow the adjustment of the internal coffee group pressure increasing the height of the chamber (from 0 to 10 mm);</li> </ul> <p>press "2" to display:</p> <p>press keys "4" and "5" to change the rotation time of the N product motor, thus changing the product quantity you have dispensed; if time is zero, no product N will be dispensed; you can carry out a "time test" on the set-point; (see 13.17.);</p>	<p>programming: TOTAL</p> <p>programming: PARTIAL</p> <p>COFFEE WATER EXP. 0= inhib. cc: 00</p> <p>coffee sequence 1=coffee before N</p> <p>Brewer pressure 0=max 10=min. 00</p> <p>PRODUCT N 0= inhib. 0.0</p>

	if the time you have programmed is other than zero, the N product motor will be activated at the expiry of the delay time you have programmed; the delay time is increased or decreased by pressing keys "4" and "5";	start delay PRODUCT N 0.0
	the rotation time of the product motor can be briefly interrupted one or two times during the dispensing cycle (0 = no break); (see also 13.16.);	breaks number 0-1-2 00
	parameter used to adjust the amount of grounded coffee will be dispensed and filled into the coffee brewer;	coffee time grinder 0.0
	if you enable this option after having compressed the ground dose, the pump will deliver a small water quantity to make it wet, stop and restart the usual dispensing cycle; the stop time can be here programmed from 01 to 15;	T. AFTER PREINF. 0=NO SEC.:00
	to determine the solenoid valve opening time and then the water quantity it will deliver; you can carry out a "time test" on the set-point; (see 13.17.);	WATER N time 0= inhib. 0.0
	water will be dispensed in the mixing bowls at the expiry of the delay time you have programmed;	start delay WATER N 0.0
	the rotation time of the mixer fan can be changed by pressing keys "4" and "5"; if time is equal to zero, the mixer will not rotate; you can carry out a "time test" on the set-point; (see 13.17.);	MIXER N 0= inhib. 0.0
	if the rotation time is other than zero, the mixer fan will be rotated at the expiry of this delay time;	start delay MIXER N 0.0
	the mixer rotation speed can be regulated between low, medium, high by pressing keys "4" and "5";	MIXER speed N medium
LM dispensing	to establish the delay between the second milk and the espresso coffee dispensing cycle in the "Latte macchiato" selection;	Latte-Macchiato start brewer 0.0
LM dispensing	to establish the milk quantity of the second dispensing cycle;	PRODUCT LM 0= inhib. 0.0
LM dispensing	to determine the delay of the second milk dispensing cycle;	start delay PRODUCT LM 0.0
LM dispensing	to determine the breaks of the second milk dispensing cycle;	breaks number 0-1-2 00
LM dispensing	to establish the water quantity of the second milk dispensing cycle;	WATER LM time 0= inhib. 0.0
LM dispensing	to determine the water quantity delay of the second milk dispensing cycle;	delay water LM 0= inhib. 0.0
LM dispensing	to establish the mixer rotation time of the second milk dispensing cycle;	MIXER LM 0= disab. 0.0
LM dispensing	if other than zero, the mixer power on will be delayed by the time you have set up;	start delay MIXER LM 0.0
LM dispensing	to determine mixer rotation speed of the second milk dispensing cycle;	MIXER LM speed medium
LM dispensing	to specify the product canister to be used for the milk dispensing cycle;	PRODUCT MILK LM n: N
LM dispensing	to establish the water to be used for the second milk dispensing cycle;	LM Milk water Number= 0

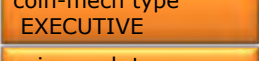
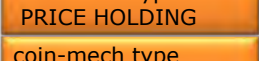
	<p>to repeat the selection by N times automatically and produce drinks of remarkable volume (jug);</p>	
	<p>press "4" and "5" to choose the drink name to display during the dispensing cycle; options are listed here below:</p> <ul style="list-style-type: none"> <li>- "standard", the display will show "drink N under preparation";</li> <li>- "list of names" of drinks made available in the machine memory; the display will show "drink name under preparation";</li> <li>- "custom": the display will show the user's customised names; it is necessary to create a configuration file with rheAction (see 05.39.) and load it on the machine by means of a flash key see 09.06.);</li> </ul>	
<p>"pre-selection"</p>	<p>several pre-selection messages are made available according to the various machine releases; they are supplied here below:</p>	
<p>"decaffeinated/barley":</p>	<p>espresso coffee can be replaced with instant coffee (or barley) by means of pre-selection; variables are listed here below:</p> <ul style="list-style-type: none"> <li>- message appearing on the display during the dispensing cycle;</li> <li>- decaffeinated product canister (keys "4" and "5");</li> <li>- mixing bowl and mixing water (keys "4" and "5");</li> <li>- price change with respect to the standard espresso drink; (see *);</li> <li>- keys for which preselection has effect (scroll by means of key "2" and select enable or disable by means of key "4" and "5"); this instruction is repeated in any preselection to enable the effect in the key or not (*);</li> </ul>	    
<p>"extra milk"</p>	<ul style="list-style-type: none"> <li>- to choose the milk canister;</li> <li>- to determine by how many seconds to change the rotation time of the product motor you have set up in the configuration; to enable see (*);</li> </ul>	 
<p>"espresso"</p>	<ul style="list-style-type: none"> <li>- to decrease the NN water percentage to the water you have set up in the espresso selections; to enable see (*);</li> </ul>	
<p>"no sugar"</p>	<ul style="list-style-type: none"> <li>- to choose the sugar canister; to enable see (*);</li> </ul>	
<p>"extra sugar"</p>	<ul style="list-style-type: none"> <li>- to choose the sugar canister;</li> <li>- to determine by how many seconds to change the rotation time of the product motor you have set up in the configuration; to enable see (*);</li> </ul>	
<p>"sugar"</p>	<ul style="list-style-type: none"> <li>- to choose the sugar canister; to enable see (*);</li> </ul>	

09.01.b. prices	press key "2" to display: each selection can be assigned a sales price; use "4" and "5" to change the amount and "2" to scroll the price lines;	
09.01.c. happy price	press key "2" to display: every single selection may be assigned a sales price that will be valid only in well-defined time ranges (see 09.01.l. "clock"); use "4" and "5" to change the amount and "2" to scroll the price lines;	
09.01.d. coins	assign each channel its value for the parallel payment system; press "2" to scroll the coins from A to J and use "4" and "5" to change its value;	
09.01.e. temperature	press key "2" to display:  use keys "4" and "5" to change the pressure boiler temperature;  to establish how many minutes after the latest espresso to activate the following parameter;  to establish the power on time of the pressure boiler heating element to increase the water temperature;  to determine the temperature at which to heat the coffee brewer during operation;  (see also 10.03.);	   
09.01.f. miscellaneous	the "miscellaneous" item includes some options (press keys "4" and "5" to modify the values of these options):  - machine code A and B: you can number the machine to distinguish it from others similar (data collection);  - message number: press keys "4" and "5" to choose the messages to display on the screen when the machine is in standby mode;  - coin mechanism programming options: press keys "4" and "5" to display the options of communication with the payment system; choose among:  - parallel single vend  - parallel multiple vend  - executive  - executive price holding  - MDB	        



- fan time: to determine for how many minutes after the latest dispensing cycle the powder suction fan will remain active;
- beep time: beep time active at the end of each machine function;
- number of decimals: to determine how many decimals are considered in the comparison between the selection price and the credit you have inserted;
- language: to display the messages in one of the three languages made available;
- display colour; to select the display aspect you wish;
- first installation: used to make sure that the water circuit will be filled in at the next power on; if the value is zero, the machine will perform the cycle just as for 08.02 at the next power on;
- as first step of the deinstallation cycle, choose the machine type: "0" for PRO machines (400 cc pressure boiler); "1" for PRO VHO machines (800 cc pressure boiler);
- deinstallation: to empty water circuits automatically:
  - detach the water supply and press "10";
  - following the display's messages, verify that the drip tray and the grounds container are empty an press key "10";
  - insert an extension into the pressure boiler drain tube, remove the plug of the discharge air break tube, put it close to a bucket and press "10";
  - only in PRO machines, open the pressure boiler drain tap and press "10" ;
- the display shows:
  - only in PRO machines, close the pressure boiler tap, when the display shows:
  - remove the tube and reinsert the plug of the air break;

at the end of the uninstal cycle, the boiler water temperatures will be set to zero and the machine will be set to "FIRST INSTALLATION=0";

- to enable the summer time function (from the last Sunday in March to last Sunday in October, the set time is automatically increased by one);
- if enabled, press key "PROG" to reset the water filter decouner;
- only in VHO, it enables the product sensor in the coffee beans canister;

09.01.g. diagnostics

press key "2" to access diagnostics and to enable the machine to display (keys "4" and "5") the standby message and the boiler water temperature, alternatively;

press "2" once again to display the voltage value intended to supply devices at 24 V dc;

fan time min.	NN
Beep time	0.0
decimal number	N
language :	english
display color	00
first installat. 0=first	N
Boiler cc 0=400 1=800	N
Deinstallation 10=START	
driptray empty?	10=START
remove coffee grounds	10=START
connect boiler tube	10 = >
open boiler tap	P10= START
deinstallation in progress..	
END Close boiler tap	
summer time	1=yes 0
activ. H2o filter Reset	0=no 0
ENABLE COFFEE SENSOR	1
ENABLE DISPLAY TEMPERA.	1=YES N
VOLTAGE volt	00.0

# Cino XS grande PRO and PRO VHO by rheavendors group

09.01.h. sales audit

this menu is intended to gather the quantities of the selections made by the machine: names are assigned according to the EVA-DTS standard:

- VA 102  
quantity of total vends (parameter not resettable);
- VA 104  
quantity of the vends made after the reset;
- VA 101  
total amount of receipts (parameter not resettable);
- VA 103  
total amount of receipts after the reset;
- VA 202  
quantity of total tests (parameter not resettable);
- VA 204  
quantity of tests after the reset;
- VA 302  
quantity of free vends (parameter not resettable);
- VA 304  
quantity of free vends after the reset;
- CA 201  
total amount sold by cash (parameter not resettable);
- CA 203  
total amount sold by cash after the reset;
- CA 202  
total amount of the selections sold by cash;
- CA 204  
quantity of the selections sold by cash after the reset;
- CA 305  
total amount of cash receipts;
- CA 301  
partial amount of cash receipts;
- DA 401  
total amount loaded on RFID cards;
- DA 402  
total amount loaded on RFID cards after the reset;
- DA 201  
total amount sold by means of a RFID card;
- DA 203  
total amount sold by means of a RFID card after the reset;
- DA 202  
quantity of selections sold by means of a RFID card;
- DA 204  
quantity of selections sold by means of a RFID card after the reset;
- LA 1\*1  
selections sold at a standard price;
- LA 1\*2  
selections sold at a happy price;
- PA 403  
free selections;

TOTAL SELECTIONS	NN
PART. SELECTIONS	NN
TOTAL MONEY	0.00
PARTIAL MONEY	0.00
TOTAL TESTS	00
PARTIAL TESTS	00
TOTAL FREE	00
PARTIAL FREE	00
TOTAL CASH	CASH 0.00
PARTIAL CASH	CASH 0.00
N. TOT. SEL. CASH	00
N. PAR. SEL. CASH	00
TOTAL CASH-BOX	0.00
PARTIAL CASH-BOX	0.00
total loaded on card	0.00
part loaded on card	0.00
total unloaded card	0.00
part unloaded card	0.00
TOTAL SEL. CARD	00
PARTIAL SEL. CARD	00
TOTAL SEL. N	00
TOTAL SEL. N HAPPY	00
TOTAL SEL. N FREE	00

# Cino XS grande PRO and PRO VHO by rheavendors group

09.01.i. MDB press "2" to display the variables necessary for the MDB protocol; since **Cino XS grande PRO and PRO VHO** is unable to accommodate changegiver payment systems, some of these variables will be of no significance, even if made available; press keys "4" and "5" to scroll the values;

- tube dispensing: to empty coins tubes;
- changegiver enable: to enable the coins change of the changegiver
- maximum credit: to establish the maximum acceptable credit amount;
- maximum change: to determine the maximum change amount;
- single/multiple vend: to keep the residual credit amount after a dispensing cycle or not;
- token value: to quantify the value of the token;
- coins change N: to establish the coins to be used for the change when the machine is able to give it; from A to P;
- coins no change N: to establish the coins not to be accepted when the machine is unable to give the change; from A to P;
- set "0" to enable the changegiver; "1" to enable the changegiver only if the change made available is enough or if there is the RFID card; "2" to enable the changegiver only if there is the RFID card;
- tube value: to specify the value in the ensemble of coins tubes;

Ejection tubes  
button: 4-5-7-8-9-10

escrow enable  
0=enab. 1=dis. N

credit max  
0.00

rest max  
0.00

Sell type  
0=sing. 1=mult. N

Token value  
0.00

coin rest a N  
0=acc. 1=disab. 0

coin no rest a N  
0=acc. 1=disab. 0

Bill validator  
enab.= 0,1,2 = 0

MDB tubes value  
0.00

09.01.l. clock this chapter is intended to determine:

- current time;
- current day;
- current month;
- current year;
- day of the week;

HOUR:  
00:00

DAY:  
00

MONTH:  
00

YEAR:  
00

day of week:  
(ex.) Tuesday

use the three pairs of parameters (Start FN and End FN) to establish three time bands during which the machine will apply "happy prices" (see 09.01.c.);

START FN:  
00:00

END FN:  
00:00

for each day of the week you can establish a time band during which the machine will accept no selection and reduce the water temperature of the pressure boiler;

SWITCHING ON:  
xxxxx 00:00

SWITCHING OFF  
xxxxx 00:00

to count the energy consumption of the machine;

Kilowatt hours:  
0.0

the machine will perform a wash cycle at the time you have specified provided that it has performed at least five dispensing cycles after the last cycle;

CLEANING:  
00:00

# Cino XS grande PRO and PRO VHO by rheavendors group

09.01.m. out of service to display the recording of the twenty errors last occurred in the machine; press key "2" to scroll the records and key "4" to reset the recording (see 11.);

n. N off NN  
hh:mm dd-mm-yyyy

09.01.n. product qty each product motor can be assigned a time credit in seconds that will be decreased at each dispensing cycle of that product; after having used up the credit, the machine will answer <<selection not available>> whenever a request is made for that product; this control is disabled at the beginning and the machine has got no constraint; to programme the credit time of a product motor, set the variable by pressing key "4" and "5";

product qty N  
[ 0.0] 170.0

after having reached the time quantity you wish, press key "PROG"; the value will be copied between parentheses on the left of the display;  
programmable products from 1 to 6;  
quit the programming mode as usual;

product qty N  
[170.0] 170.0

please note that the first warning threshold can be programmed; if exceeded, the display will show an alarm message without interfering with the operation of the machine;

prod. N warning  
threshold: 17.0

after having used up the time credit, the operator may decide whether to inhibit or not the dispensing cycle of the selections, including that product;

enable stop prod. N  
1=stop 0

an operator, which can not access the programming mode because, for example, does not know the password, once the containers loaded with the appropriate products may can set all the values products decounters at their original values; to do this, he has only to keep pressed button "PROG" for about 10-15 seconds until the display shows:

SET PRODUCT  
=====OK=====

09.01.o. maintenance in this ensemble of parameters, key "2", you can set up some counters to trigger an alarm after a programmable number of events (press "4" and "5" to set up and PROG to store):

- dispensing cycles before having to replace the cartridge of the external filter, if any; as soon as 500 dispensing cycles are left, the display will show "change water filter" and as soon as the decounter has reached 0, it will display "out of service water filter", thus inhibiting the operation of the machine;

water filter cnt  
[ 00] 00

- espresso dispensing cycles before having to service the coffee brewer; as soon as 5 dispensing cycles are left, the display will show "make brewer cleaning" and as soon as the decounter has reached 0, it will display "out of service cleaning brewer", thus inhibiting the operation of the machine;

dec. cof. brewer  
[ 00] 00

- espresso dispensing cycles before having to empty the grounds container ; as soon as the decounter has reached 5, it will display the message "remove coffee grounds" until the decounter has reached 0, thus inhibiting the operation of the machine and the display will show "out of service coffee grounds";

dec. cof. grounds  
[ 00] 00

09.01.p. rfid card

- the maximum credit you can load from the RFID card;
- 0 for each coin (from A to J) that can be accepted when the RFID card is available;
- 0 for each coin (from A to J) that can be accepted when the RFID card is not available;

max credit card  
0.00

coin A N  
with card 0=acc.

coin A N  
no card 0=acc.

09.01.q. tuning motors with respect to the setup in 09.01.a:

- the rotation time of every single product motor can be changed (key "4" and "5") by +/- 30%; the change concerns all the activations of the product motors for all selections;
- the time required to activate the grinder motor can be calibrated by +/- 30%, according to the values set up for each selection; once fixed, even this increase or decrease is constant for each activation;

tuning motor N  
+00 %

tuning grinder N  
+00 %

09.01.r. calibration product flux

this procedure will convert the programming of the doses of grounded coffee expressing in grams rather than, as usual, in seconds of activation of the grinder motor;

to perform this procedure, you must have the following:

a container (cup) to collect the doses of ground coffee;  
a balance with 50 grams scale (d = 0.01 gram);

before starting the calibration procedure, it is necessary to weigh the container (cup) that will collect the grounded coffee;

the calibration

press key "2" to enter, the display shows:

press PROG;

remove the variable coffee brewer (see 13.07.);

put in place the coffee grounded conveyor and properly place the cup to collect the dose;

press PROG; the machine performs two grinding cycles;

the grounded obtained must weigh 20 grams; if this is true, press the key "1"; if not, set the amount weighed by pressing the keys "4" and "5" to change the digits on the display in the lower right corner; at the end, press the key "1" (remember to subtract the weight of the empty cup);

the display shows:

reinstall the coffee group and all the others components (coffee conveyor, carter, drip tray, ...) and press PROG;

the machine will store the data entered; wait for the end of this automatic cycle, which also includes a switch off/switch on cycle without manual intervention;

at the end of this procedure, the display will show the usual stand-by messages:

after that, in each recipe that includes the coffee beans, the dose will now be expressed in grams of grounded coffee and the machine will compensate the variations of dose while maintaining constant the quantity; the natural wear of the blades which over time tends to decrease the amount of coffee poured into the group, will be well automatically compensated without any outside intervention;

CALIBRAT. BREWER  
SEL >PROG< 0.0

REMOVE BREWER  
AND PRESS >PROG<

readed grams 4=+  
5=- 1=ok: 20

REINSTALL BREWER  
AND PRESS >PROG<

Cino XS  
ESPRESSO

place your  
cup

for every soluble canister can be set the delivered grams' quantity by second (key "4" and "5");

09.01.s. product audit flux display the partial and the total quantity of delivered product; the partial audit can be erased by pressing the key "4" for some seconds;

09.01.t. machine id. identification codes for data acquisition in EVA DTS:

- machine number;
- location number;
- machine configuration;
- address for the connection with the DDCMP protocol;
- 0 for the audit via telemetry; 1 to enable the IRDA acquisition; 2 to disable the acquisition;

09.01.u. variflex to set the diameter of the coffee brewer installed in the machine;

it decides whether to keep the percolation chamber of the coffee brewer inserted in the upper piston or not in the standby phase (close);

to enable the grinder calibration time;

09.02. "data" choose the option "data" to enable the display to show the data of the dispensing cycles you have performed in succession, just as in 09.01.h.;

09.03. "test vend" to dispense selections on a free basis; the selections made in this mode are counted separately (see 09.01.h.);

09.04. "clean" choose this option and press "1=pb", "2=mx1", "3=mx2" , "4=water" or "8=pb A." to enable the vending machine to dispense a pre-fixed water quantity to wash the corresponding circuit (see 08.03.);

09.05. "maintenance" to carry out the same functions as those described by point 09.01.o.;

09.06. data support the values of the variables composing the machine programming (configuration) can be transferred to an external support, i.e. the flash key; to transfer the machine parameters to the key:

- power off the machine;
- open the door;
- insert the flash key into the orange carter slot (see 05.14. and 05.37.c);
- power on the machine with the service key (see 05.12.);
- the display shows:
- press "2";
- and wait for the display to show:
- power off the machine and remove the flash key;

now, the flash key contains all the parameters typical of the machine from which they have been fetched. If you wish to programme another vending machine with these data, the previous procedure can be repeated by pressing key "1" instead of "2": the information will be transferred from the flash key to the vending machine; both procedures will not alter the data contained in the supports from which they have been fetched;



calibr. motor N  
gr/sec

product N used  
Parz. g. 00

product N used  
Tot. g. 00

code ID 101  
00

code ID 104  
00

code ID 106  
00

address VIDTS  
00

Data Audit 0=TLMS  
1=IRDA 2=off 00

BREWER DIAMETER  
0=36 1=45 00

POSIT. STAND BY  
0=close 1=open 00

Autom. Adjustment  
f. Tuning 1=yes 0

TEST VEND

CLEANING  
butt: 1=pb 2=mx1  
3=mx2 4=water  
8=pb A.



1 from key to VMC  
2 from VMC to key

END PROGRAMMING  
wait .....

09.07. programming diagram

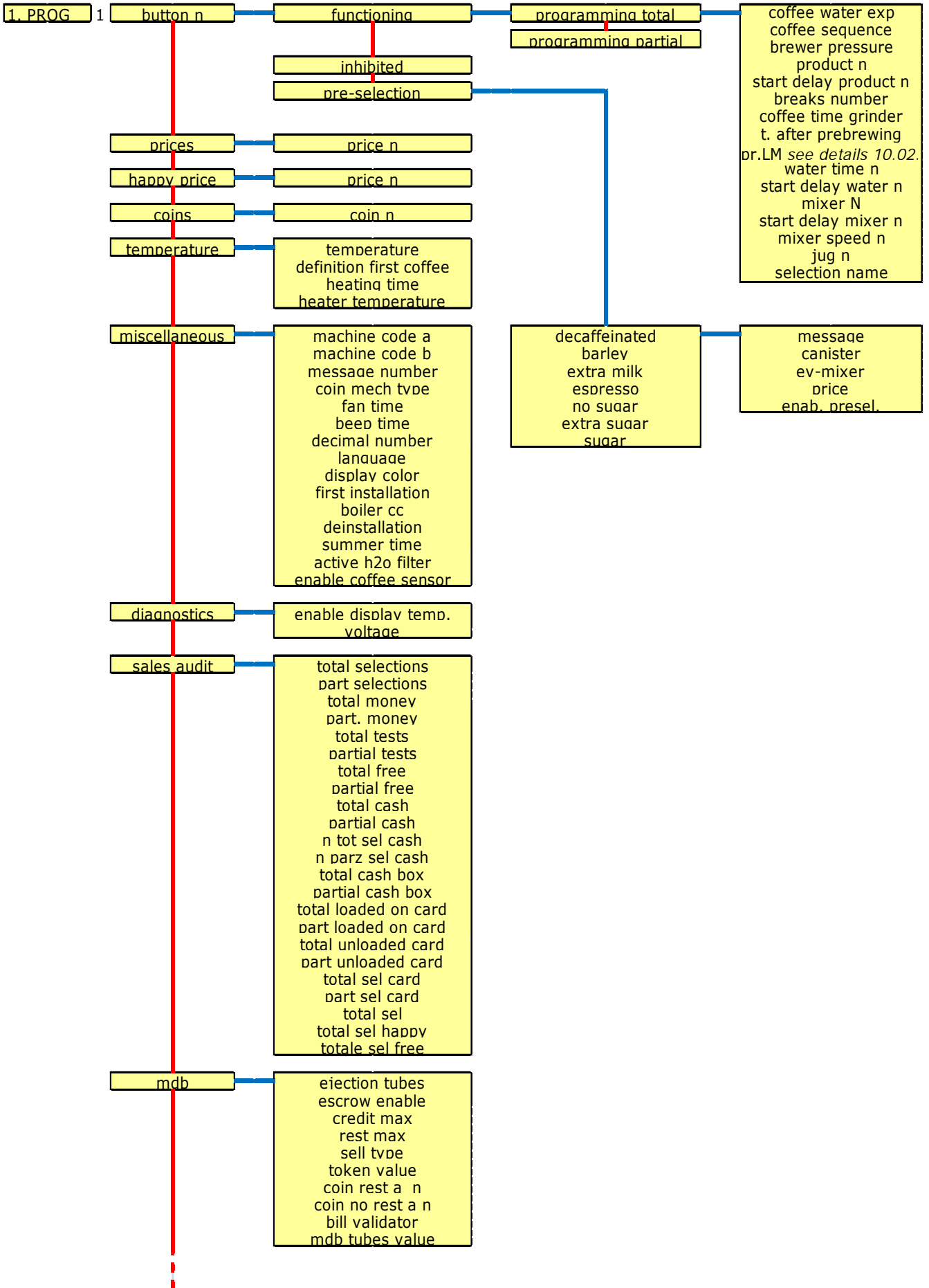

09.07. programming diagram

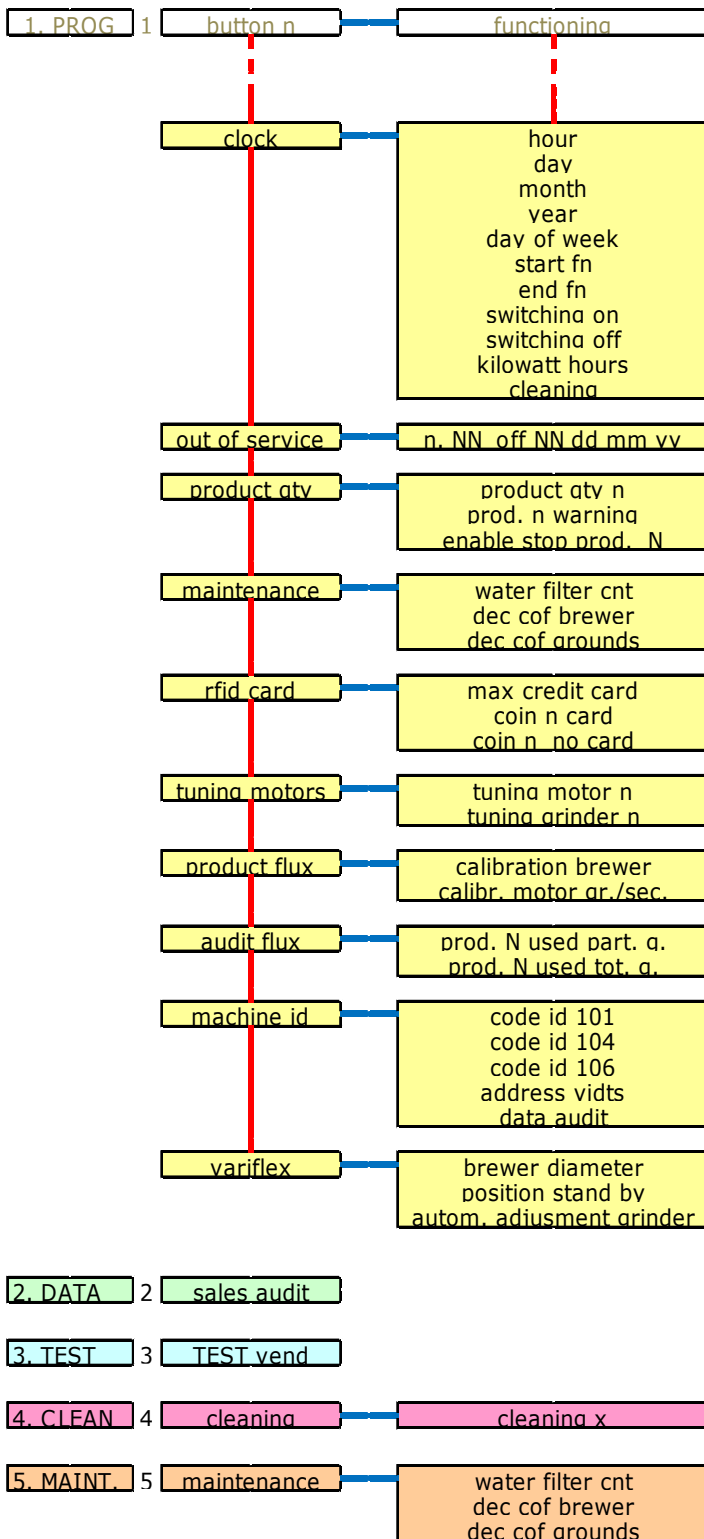



**10. parameters**

the following tables are intended to supply some information on the programmable parameters of the **Cino XS grande PRO and PRO VHO** software; if not otherwise specified, the numeric time values of devices are understood in tenths of a second (e.g. 27 corresponds to 2 seconds and 7 tenths);

10.01. configuration

the generic parameters intended to dispense the drinks with the different possible products are supplied here below, just by way of example; these values enable the operator to program the selections of reference and they can be used to obtain some functional dispensing cycles even if it may be necessary to make some slight changes to appeal to the users;

01. espresso	water exp.	45		
02. coffee	prod. 6	10	delay water 2	15
	water 2	40	delay mixer 2	20
	mixer 2	60		
03. milk	prod. 4	35	delay prod. 4	10
	water 1	110	delay mixer 1	5
	mixer 1	115		
04. cappuccino	water exp.	65		
	prod. 4	25	delay prod. 4	10
	water 1	50		
	mixer 1	60	delay mixer 1	5
05. chocolate	prod. 3	45	delay prod. 3	15
	water 1	120	delay mixer 1	5
	mixer 1	135		
06. tea	prod. 6	35	delay prod. 6	15
	water 2	120	delay mixer 2	5
	mixer 2	135		
07. tea with milk	prod. 4	12	delay prod. 4	12
	prod. 6	35	delay prod. 6	70
	water 1	50		
	mixer 1	65	delay mixer 1	5
	water 2	70	delay water 2	60
	mixer 2	85	delay mixer 2	65

see 04.02.

product canisters

chocolate P3  
milk P4  
coffee P6

or tea P6

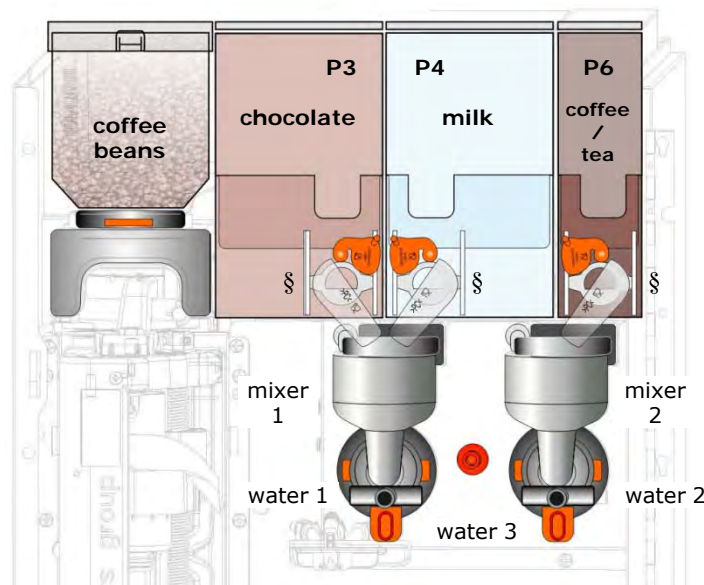

10.02. LM selection

Cino XS grande PRO and PRO VHO can produce a drink called Latte Macchiato, composed by milk and coffee and served in the cup in differently coloured bands, typically milk, coffee and milk;

to get this special drink, refer to a specific package of instructions, every step of which is called "LM dispensing cycle";  
le erogazioni di prodotto in sequenza sono:

- dispensing cycle of 1<sup>st</sup> mixed milk (at low speed rate);  
10÷15 second pause;
- dispensing cycle of 2<sup>nd</sup> mixed milk (at high speed rate);  
12÷20 second pause;
- dispensing cycle of espresso coffee;



2° MILK  
ESPRESSO COFFEE  
1° MILK

the different milk consistency due to a different mixing treatment enables coffee to remain in a central range, thus giving origin to the "Latte Macchiato" drink;

act as follows in the programming menu:

flow diagram, "Latte Macchiato" selection;

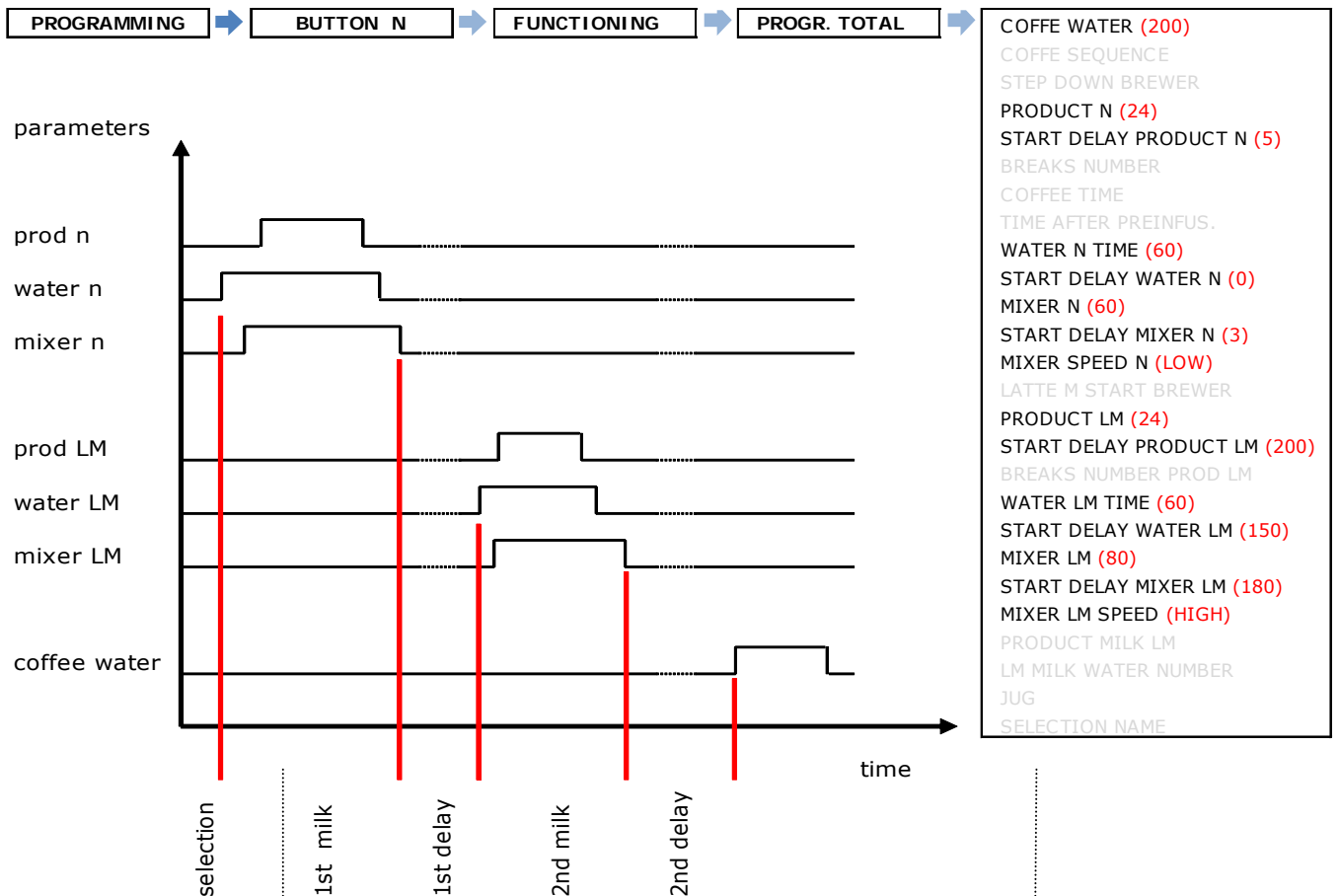

the data supplied by the table provide for a "latte macchiato" dispensing cycle and they can be adapted to achieve dispensing cycles more suitable for the users' wishes;

10.03. limits

the table is intended to list the minimum and maximum values you can assign to programmable variables;

	m.u.	from	to
exp coffee water	n.	0	250
product	sec.	0	20
product start delay	sec.	0	20
number of product pauses	n.	0	2
water time	sec.	0	20
water start delay	sec.	0	20
mixer	sec.	0	20
mixer start delay	sec.	0	20
mixer speed	→	→	→
temperature pressure boiler	°C	0	105
first coffee temperature	°C	0	105
first coffee time	min.	0	20
heater temperature	°C	0	40
product decounter	sec.	0	6.000
machine code A e B	n.	0	65.535
message number	n.	0	7
fan delay	min.	0	180
beep time	sec.	0	1,5
number of decimals	n.	0	3
coin A ÷ J	n.	0	65.000
prices 1 ÷ 10	n.	0	65.000
tuning motor	→	→	→
tuning grinder	→	→	→

0 = no espresso;
0 = no product;
0 = no delay;
0 = no pause;
0 = no water;
0 = no delay;
0 = no mixer;
0 = no delay;
low, medium, high

0 = no limit;
---------------

+/- 30%
+/- 30%

**11.**  
**solution of problems**

any event that may occur during the operation of a machine may totally or partially compromise its functionality;

to help the operator restore the normal functionality of the vending machine, the display shows an error code as an abbreviation that identifies the malfunction and helps the operator find the faulty device;

the content of this chapter is intended to collect, expand and comment upon these abbreviations, which are forcedly concise, to facilitate the solution of the failure;

please note:

- 1° in the machine, the error may be signalled with or without a suffix that – if present – is intended to specify the meaning better; however, the number on the display identifies for sure the devices, assemblies and functions in question;
- 2° in the following table:
  - the first column shows the machine number; any variant is shown with the detail letters for more specification;
  - the second shows the machine district or function affected by the event;
  - the third one contains a comment, the purpose of which is to help find a solution; these notes are surely not exhaustive because a malfunction may have several causes or be originated by an ensemble of factors, but they any way give some hints on how to proceed;
- 3° not all malfunctions are signalled by an error message since the latter is generated by electric controls that are not made available in all machine districts;
- 4° this document is meant only for the technicians who are – at least briefly - familiar with the technologies, machines, devices and names generally used in the vending field; the wiring diagrams supplied with the machine are absolutely necessary to understand and solve the events described herein;

**attention**



while performing the actions necessary to restore the machine functions, act with the utmost caution and strictly observe the safety instructions for operators and users;

<b><u>OFF 2</u></b>	<b><u>payment system</u></b>	
	<b><u>protocol</u></b>	
OFF 2 E	executive	no communication between the payment system and the vending machine CPU; it might be caused by improper power supply, false programming or payment system malfunction;
OFF 2 M	MDB	
OFF 2 P	parallel	
<b><u>OFF 3</u></b>	<b><u>waste water bucket</u></b>	the switch controlling the liquid level in the bucket has tripped because operated by the floater; make sure that it is properly positioned after the bucket has been emptied;
<b><u>OFF 5</u></b>	<b><u>EAROM</u></b>	those integrated in the CPU board fail to operate properly;
<b><u>OFF 6</u></b>	<b><u>water supply</u></b>	
OFF 6 C	air break	the water supply might be totally lacking, its pressure might be not enough or some obstacle might slow down the regular water flow (filter grilled cover, load pipes either choked or clogged); the water inlet solenoid valve safety has tripped;
OFF 6 D	air break	the pressure boiler circuit has been refilled with water, but no drink has been dispensed; the supply circuit might have a leakage;
OFF 6 G	pressure boiler	during the first installation phase, water inlet error in the machine; after having opened the water inlet solenoid valve and activated the pump, the volumetric counter shall send the CPU a sequence of pulses to give evidence that water is flowing; if this does not occur, error 6G is triggered;
<b><u>OFF 7</u></b>	<b><u>espresso circuit</u></b>	
OFF 7 A	pompa espresso	the power-on time of the espresso circuit pump has exceeded the limit; the water flow has encountered more resistance than usual and the pulses produced by the volumetric counter have required a time interval deemed to be too long for a dispensing cycle within proper limits; also check the grinding amount and degree of coffee beans poured into the coffee brewer chamber;
<b><u>OFF 8</u></b>	<b><u>coffee brewer</u></b>	
OFF 8 A	piston	initial positioning error;
OFF 8 B	presence	the machine fails to recognise the presence of the coffee brewer in its correct working position;
OFF 8 C	piston	the brewing chamber is not moving properly;

<b><u>OFF 10</u></b>	<b><u>EAROM</u></b>	stored data are not consistent (reading or writing error) and the overall operation of the vending machine may be otherwise than expected;
<b><u>OFF 14</u></b>	<b><u>water inlet</u></b>	
OFF 14 B	pressure boiler	if water is not reloaded after six dispensing cycles, error 14 is triggered; even a water inlet pressure value other than the pre-set one, may cause this error, thus filling in the pressure boiler in excess and providing for a number of dispensing cycles higher than the pre-set one; if selections are dispensed with a limited water quantity, the error is more likely to occur;
<b><u>OFF 16</u></b>	<b><u>programming keyboard</u></b>	the programming keyboard inside the machine has a short-circuited key or it has been pressed too long; if pressed too long, the manual release button of cups turrets may cause this error;
<b><u>OFF 17</u></b>	<b><u>keyboards</u></b>	
OFF 17 A	selection	a button appears as if it were constantly pressed;
<b><u>OFF 24</u></b>	<b><u>power supply unit</u></b>	
OFF 24 A	24 V dc	the actual 24 V dc voltage value is higher than the tolerated one;
OFF 24 B	24 V dc	the measured 24 V dc voltage value is below the admitted threshold or totally absent, e.g. because a fuse has tripped; find out and remove the causes that have produced this error before powering on the machine again;
<b><u>OFF 31</u></b>	<b><u>espresso coffee water</u></b>	
OFF 31 A	temperature	the pressure boiler water temperature is higher than the programmed value;
OFF 31 B	temperature	water fails to achieve the set temperature;
OFF 31 C	pressure boiler probe	the temperature probe is interrupted or its electric connector is detached;
OFF 31 D	time	the temperature fails to achieve the programmed value within the admitted time limit;
<b><u>OFF 77</u></b>	<b><u>CPU</u></b>	the "clock" function is not properly performed; the buffer battery might be low; after having restored the function, carefully check the clock-related machine functions: happy hour, time bands, ... that might have been compromised by the lack of time references;
<b><u>OFF 80</u></b>	<b><u>MDB change giver</u></b>	
OFF 80 4	pipes	a pipe sensor is not properly working;
OFF 80 6	validator	validator not inserted or disconnected;
OFF 80 7	pipe	a coin pipe is not properly working;
OFF 80 8	memory	ROM with reading/writing error;
OFF 80 C	coin	coin locked in the acceptance path;
OFF 80 D	coin	attempt at fraud and coin removal;

**12.  
maintenance**

the Cino XS grande PRO and PRO VHO vending machine requires no special maintenance procedure to do its job; however, if you provide for careful and frequent cleaning, this may help the machine keep its performance constant, prevent failures and ensure the high quality of dispensed drinks; the frequency of cleaning operations largely depends upon the number of dispensing cycles and the hardness of water in use (use a softener system) and it shall be adjusted to the working conditions of the vending machine;

the actions described are intended to prevent the bacterial growth in the machine areas directly in contact with foodstuffs and to keep the parts conveying drink-composing products clean; after having disassembled the parts of the machine listed here below, use plenty of lukewarm water to remove any residue that might build up;

the support of a bacterial static or bactericidal solution may strengthen a deep cleaning action, provided it is compatible with human health and the supply of foodstuffs; reassemble all the parts you have cleaned after having dried them by means of a clean piece of cloth;

refer to the content of the Internet address:

[http://ec.europa.eu/food/food/biosafety/hygienelegislation/index\\_en.htm](http://ec.europa.eu/food/food/biosafety/hygienelegislation/index_en.htm)

this site is intended to supply the European Parliament recommendations for properly and safely processing foodstuffs; consult also the 2004/852/EC European Community regulation

<http://eur-lex.europa.eu/LexUriServ/LexUriServ.do?uri=OJ:L:2004:139:0001:0054:IT:PDF>

before accessing the machine for each maintenance operation, it is recommended to warn the users by means of boards properly positioned that it is forbidden to approach the vending machine and to use it;



**attention**

**never wash the machine by using water jets;**

**wash hands thoroughly with water and soap before handling the machine and the products;**

**only use potable water;**

**all components must only be cleaned with warm running water;**



12.01. weekly

power off the machine; detach the power supply cable and carefully make sure that there is no sign of wear; carefully check the stability and efficiency of the internal connections of the mains supply;

drip tray

extract the drip tray (a), remove the upper grilled cover and wash with plenty of water; open the door and clean the drip tray housing and the nozzle holder spout inside the machine (e);

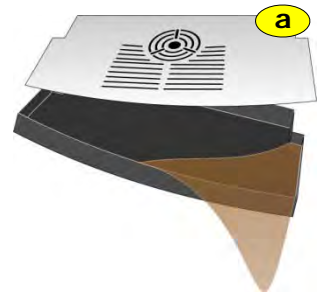

grounds container

after having opened the door and removed the drip tray, pull the right side of the drawer forward and remove it; observe the position of the water inlet tube of the brewer;



**attention**

the residual coffee grounds shall be disposed of in observance of the sanitary obligations in force in the country;

product slides

turn the baffles of product slides (c) into a close-position, remove them from the canisters and wash them with plenty of lukewarm water (product slides are plug-in secured);

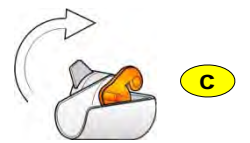

dispensing system

turn the fixing levers of mixing bowls clockwise (d), remove the product nozzles from the holder by releasing them, pull the mixing bowl and the dust extraction ring; wash the assembly of disassembled parts with plenty of lukewarm water;

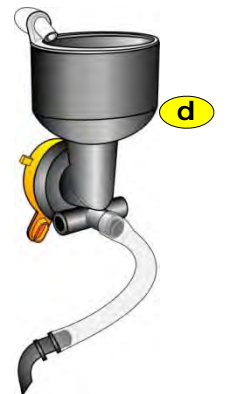

inner side of the machine

remove all residues from the internal surfaces of the machine and the door, above all in the proximity of the cup station and clean with a piece of wet cloth;

dry the parts carefully and re-mount them on the machine;

after opening the door, re-connect the supply cable and power on the main switch;

use the service key;

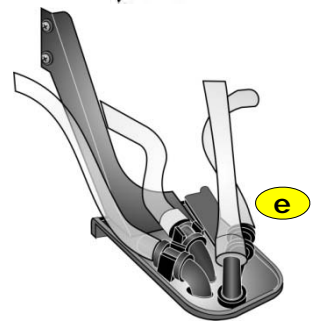

**attention**

act extremely carefully;

the vending machine is supplied and running to all effects; the mobile parts of the coffee brewer will be handled; act extremely carefully;

perform some wash cycles of the hydraulic machine circuits (see 08.03.);

remove the service key, put it into its housing, close the door;

external body

clean outside the machine by using a piece of non-abrasive cloth, dampened with lukewarm water; use a neutral, non-foamy detergent, only if necessary;

**attention**

use neutral detergent products only; never use abrasive cloths, steel sponges, aggressive or foamy detergents and other solvents, hot water and acids;





## 12.02. monthly

besides fulfilling the tasks already specified by chapter 12.01. weekly, it is also recommended to act in the following districts:

### dispensing system

disassemble all components of the dispensing system:

- extraction drawer (f)
- water dispensing ring (g)
- mixing bowl (h)
- mixer (l)
- dispensing tubes (m)
- product dispensing nozzle holder (n)

extract the mixer fan just by pulling it; check the wear state of the w ring (i) sheathing the mixer motor shaft; wash the assembly of disassembled parts with plenty of lukewarm water;

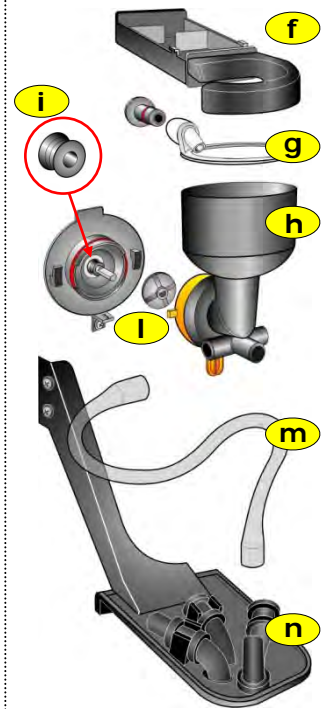

### products canister

remove the product canisters (o) by lifting them in the front and by pulling them; remove the cover and empty the product residue;

turn the baffles of product slides into a close-position; remove them from the canisters and wash them with plenty of lukewarm water, as it is described by chapter 12.01. weekly;

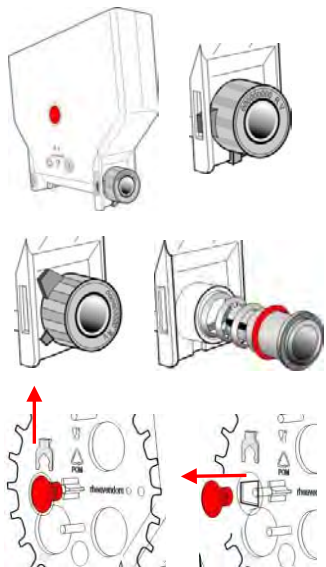

at the back of the product canister turn the black ring nut clockwise and remove it; extract the worm screw by pulling the black bush; to facilitate disassembly, push the stirring wheel in the correct direction;

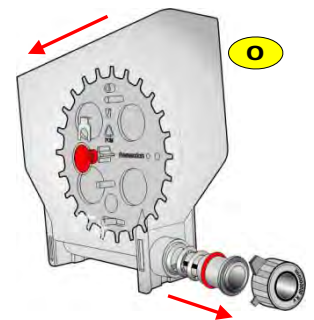

lift the two fastening clips (one for each side) from the inside of the product canister and remove the two red plugs from the outside; remove the stirring wheel; wash the disassembled parts with plenty of lukewarm water;



### coffee brewer

the whole coffee brewer can be cleaned and washed with running water since it has no component that may be damaged; to extract the coffee brewer, first remove the coffee dispensing tube from the nozzle holder, release the carter (p) by pressing on each side and by pulling it to the outside, remove the ground grey conveyor just by pulling it, remove the coffee brewer (q) by pressing the orange release button, by lifting it slightly and by pulling it;

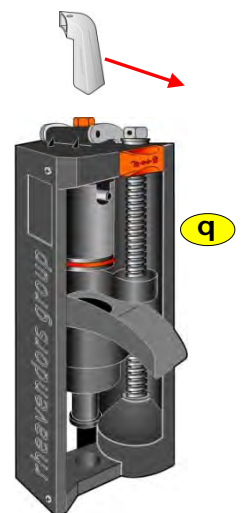

### environmental and powder aspirators

carefully check that the rotors of the two aspirators on the rear panel of the vending machine can freely rotate without any hindrance or stoppage; make sure that the corrugated tube for connection between the powder aspirator and the extraction drawer is clean and free of any product deposit;

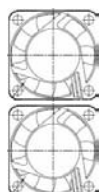

12.03. yearly

dispensing system replace the gasket at the base of the mixing bowl of the mixer; remove the mixer motor fan by pulling it; replace the gasket of the mixer motor shaft ;

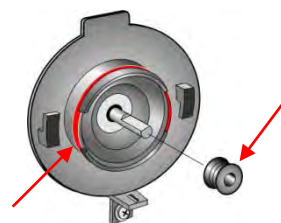

products canister disassemble the products canister from the machine; empty them, disassemble them in their basic components and wash them carefully as already described by chapter "12.02. monthly";

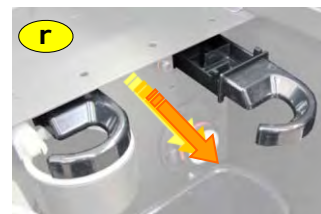

powder aspirator drawer disassemble the mixing bowls; pull out the extraction drawers (r); wash them with plenty of lukewarm water;

silicone tubes make sure that the water transport tubes are intact and that they have kept their transparency, replace them, if necessary;



coffee brewer - replace the three sealing rings (s) of the compression chamber and lower piston guide;  
- replace the upper and lower filters (t);  
- check the state of the compression chamber;



pressure boiler disassemble the pressure boiler; separate the pressure boiler from the solenoid valves block (u) and check the seal o-ring; clean the instant and espresso outlet water circuits; check the third way of the espresso valve drain by removing any trace of residue (v);



air break empty and clean the air break tank (z); carefully check the micro switch functionality operated by the floater rod and make sure that it can freely slide without any hindrance;

12.04. out of order

temporary if the vending machine should be inactive for a long period, please act as follows:

- perform the uninstall cycle (see 09.01.f.);
- detach the water and energy supply;
- empty the liquid waste tray;
- empty and clean the product canisters;
- clean the internal and external surfaces by using a wet piece of cloth;
- cover the machine by means of a cloth;
- store it in a sheltered place, at a temperature not below 5 °C, at a relative humidity not above 80%;

definitive if you should definitively set the vending machine out of commission and provide for the disposal of some parts thereof, after having carried out the operations above, disassemble the vending machine by separating every single component and subdividing the parts according to the nature of materials; the applied symbol means that the components of the vending machine shall be not processed as home rubbish, but delivered to the collection points capable of recycling electric and electronic equipment; refer to the 2002/96/EC Directive and to the relative rules;



the complete text of the European directive about this specific subject-matter is made available on the Internet site:

<http://eur-lex.europa.eu/LexUriServ/LexUriServ.do?uri=CELEX:32002L0096:IT:HTML>

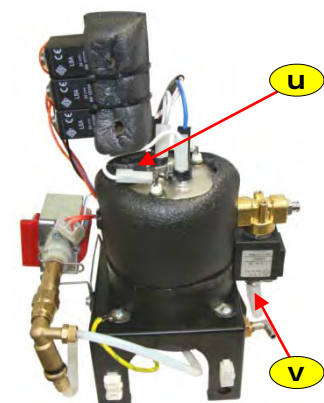

**13.**  
**how to do to:**

13.01. get an espresso selection

the parameters that determine the quality and quantity of an espresso selection in a cup are:

- the temperature and quantity of percolation water;
- the coffee grinding degree;
- the ground coffee quantity;
- the ground compression;
- the features of coffee beans;

considering the great variability of these factors, it is important to establish which are the features of the espresso most in demand by the final user and to programme the vending machine components to achieve the best result for this choice;

many of the variables contributing to dispense an espresso can be regulated via software and autonomously programmed for each selection, except for :

- the water temperature that – once set up – is constant;
- the grinding degree of the coffee beans that is manually established and – once set up – is constant;

the boiler water temperature is generally set to 92 °C ÷ 94 °C in a vending machine installed in a room where the temperature is as prescribed (5 °C ÷ 35 °C);

the grinding degree of the coffee beans – fundamentally established by the distance between the grinding wheels – can be manually adjusted by rotating the regulation ring nut;

it is assumed that a grinder with new blades is basically regulated as follows:

- by turning the regulation ring nut clockwise as far as the stop (minimum distance between the grinding wheels);
- by turning the same ring nut counterclockwise by one complete turn plus 5/8 notches;

the resulting grinding degree can be considered of reference; you can certainly adapt it to the espresso you wish by varying the distance between the grinding wheels;

guide lines

espresso coffee "Italian style" (50 cc. in a cup)	boiler water temperature:	as above;
	grinding degree:	as above;
	grinding time (for ~ 8.0 gr.)	6 sec.;
	percolation water time:	15 sec.;
	step down brewer:	no

espresso coffee "American style" (200 cc. in a cup)	boiler water temperature:	as above;
	grinding degree:	as above;
	grinding time (for ~ 12.0 gr.)	9 sec.;
	percolation water time:	35 sec.;
	step down brewer:	1;

the cup results can be certainly adapted to the final user's requests better by changing the parameters above;

13.02. insert labels

open the door and remove the orange carter; extract the two electric connectors of the keyboards; release the four holders from the front panel by removing the four safety clips; insert the labels into the pockets by observing the machine configuration;

13.03. empty the drip tray

the drip tray is arranged in its work seat and retained by the notches in the structure; pull to remove it;

see 05.06.



13.04. empty the grounds container

after having opened the door and removed the drip tray, pull the right side of the drawer forward and remove it; observe the position of the water inlet tube of the brewer;



13.05. remove the coffee hopper

insert the orange closing baffle to the bottom and lift the coffee hopper, pay attention not to spill the content thereof;



13.06. remove the instant canister

rotate the dispensing slide closure and pull the canister by lifting it slightly; to reassemble it, insert the rear bush into the motor gear and the lower pin into the horizontal surface hole; ; the product slides are plug-in mounted and removed from the canisters by turning them clockwise;

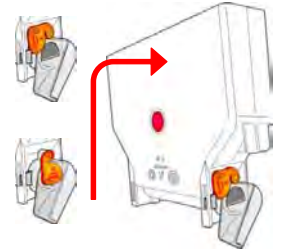

13.07. remove the coffee brewer

after opening the machine, press on each side of the protection carter (a) and remove it by letting the espresso nozzle through the groove after removing it from the nozzle holder (b); remove the ground grey conveyor by pulling it (c); pull the brewer release button (d), lift and extract it;



13.08. regulate the grinding degree

remove the coffee canister; remove the two side covers from the carter; turn the grinder ring nut (clockwise for a finer degree); the effect produced by the regulation is shown by the drink after three or four dispensing cycles;



13.09. regulate the ground dose

see software "09.01.a. grinder time" and also "13.01. get an espresso selection";

13.10. replace the o-ring of mixing bowls

remove the silicone tubes intended to dispense the product; turn the orange ring nut clockwise; pull the mixing bowl body and extract the mixer fan; you can now access the w-ring of the motor shaft, the water inlet gaskets of the mixing bowl and the mixing bowl gaskets , as already described by chapter 12.02. monthly;

13.11. replace the mixer motor

remove the silicone tubes intended to dispense the product; turn the orange ring nut clockwise and pull the mixing bowl body; unscrew the crosshead by using a PH2 screwdriver and extract the motor; the power supply wires can be removed without any tool;

13.12. replace the product motor

remove the product canister; access the rear part of the machine; extract the two small electric cables from the motor, hold the body, push it to the bottom to release it from the bayonet connection of the structure; the power supply wires can be removed without any tool (observe the polarities);

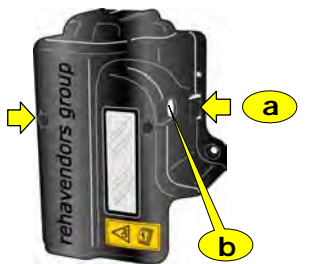

13.13. determine water and product times

the times specified by table 10.01. can be referred to as the times functional for the machine and the products to be dispensed; however, they can be adapted to the capacity of the user's cups (by changing "time water N") and its tastes (by changing "product N"); please, never forget to make sure that the dispensing time of the instant product is always lower than the one of corresponding water;

13.14. programme delays

(if accepted) dispensing starts as soon as the user presses a selection key; the order in which instant products are poured into the cup depends upon the values of delays (e.g. the one, the delay value of which is zero, will be dispensed before the one, the value of which is 40, dispensed four seconds after the user has pressed the selection key); pay special attention when programming the delays in dispensing a product and the water diluting it in the mixing bowl; except for the instant coffee product, for which just the opposite is applicable, it is recommended to dispense water before the product to enable the latter to drop on the water film already present in the mixing bowl for a better mix; espresso is dispensed before and after any instant product by programming the variable "coffee sequence";

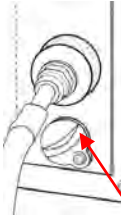

13.15. regulate the speed of mixers	the rotation speed of the motors of product mixers can be adjusted between 15,000 r.p.m. and 5,000 r.p.m.; the drink quality of instant products depends a lot upon the action of the fans of mixers: instant chocolate generally requires a long mixing time at the maximum speed for dissolution in water whereas instant tea shall not be mixed to get a drink quality without any bubble on the surface;	see 09.01.a.
13.16. choose the quantity of break numbers	if instant products can be hardly dissolved in water, it may be of use to stop the product dispensing cycle from the product canister for a short time; the water flowing into the mixing bowl will have the time necessary to remove any product build-up;	see 09.01.f.
13.17. time tests	to check the rotation time of a product motor and a mixer fan or the activation time of a solenoid valve during the programming phase, when the display shows "PRODUCT N" or "WATER N time" or "MIXER N", press the "PROG" key: the device will be activated for the programmed time;	see 09.01.a.
13.18. determine the suction fan time	to remove the residual powder of instant products from inside the machine, it is recommended to use the value in minutes you have already programmed (three); if you should use particularly volatile products, increase the time to five (and more) minutes;	
13.19. remove water	<p>to discharge the water from the machine circuits:</p> <ul style="list-style-type: none"> <li>- detach the water supply, disassemble the rear panel; connect a tube 6X9 with the drain of the pressured boiler (see 05.35.) to convey water to a bucket that shall be placed on the floor, having a capacity of at least three litres;</li> <li>- power on the machine by means of the service key, access the programming mode → "miscellaneous" → "deinstallation"; and follow the 09.01.f. point instructions:</li> </ul> <p>- the machine pump will start working to discharge water from the boiler and the tubes into the bucket; the time necessary to discharge is over six minutes to enable water to flow completely; the display shows:</p> <ul style="list-style-type: none"> <li>- while removing the fastening screw from the plug, extract the drain tube of the air break and empty it by conveying water into the bucket;</li> <li>- re-insert the plug into the tube and remount it on the machine by means of its fastening screw;</li> <li>- remove the tube from the drain solenoid valve of the boiler;</li> <li>- re-mount the rear panel of the machine;</li> </ul>	<div data-bbox="1225 996 1489 1059" style="background-color: orange; color: white; padding: 5px; text-align: center;"> <b>Deinstallation 10=START</b> </div> 
13.20. install a payment system	<p>there is a kit including all the parts necessary to install a payment system in <b>Cino XS grande PRO</b>; after having installed the components of this kit, refer to the above to programme the system functionality;</p> <p>Rheavendors Services S.p.A. is at disposal for any kind of support and information on the installation of payment systems; (see 02.02.);</p>	
13.21. return some material under guarantee	if you should return any material under guarantee that is either defective or not in compliance with your requirements, fill in the form "MOD. PO 19.01/2B Materials under guarantee – Authorisation to return" and send it to the fax number above to apply for authorisation; only after having received the authorisation form signed and numbered, you are permitted to send the goods at your expenses to the address specified by the form;	



**Deinstallation  
10=START**



# Cino XS grande PRO and PRO VHO by rheavendors group

14. hydraulic diagram

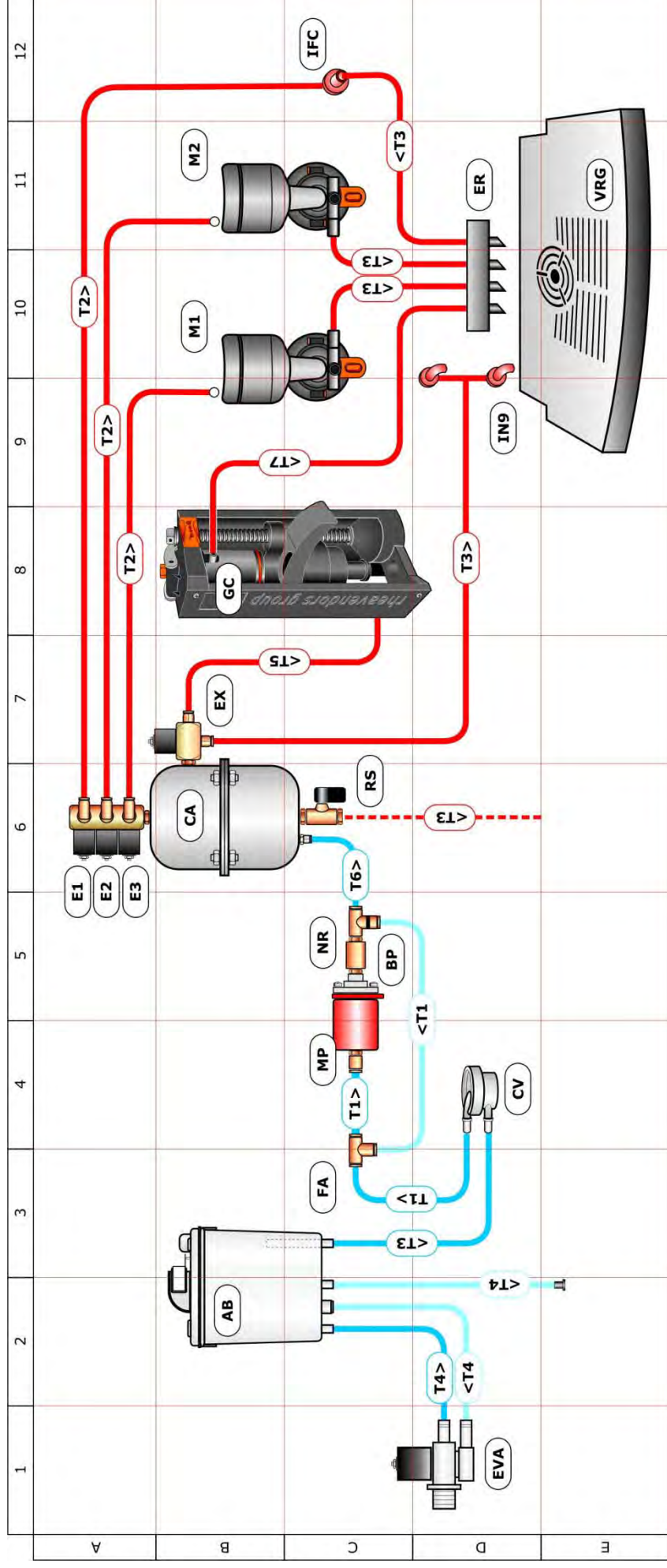

column	symbol	name	column	symbol	name	column	symbol	name	column	symbol	name
1D	EVA	water inlet solenoid valve	5C	BP	by pass	8B	GC	coffee brewer	/	T1	silicone hose 05/08T
2B	AB	air break	6B	CA	pressure boiler	10B	M1	mixer 1	/	T2	silicone hose 06/09T
3C	FA	water filter	7B	EX	three-way valve	11B	M2	mixer 2	/	T3	silicone hose 06/11T
4D	CV	volumetric counter	6A	E1	soluble solenoid valve 1	11D	ER	nozzle support	/	T4	silicone hose 07/11T
4C	MP	pompa ex 5	6A	E2	soluble solenoid valve 2	11E	VRG	drip tray	/	T5	ptfe hose 02/04T
5C	NR	non return valve	6A	E3	soluble solenoid valve 3	9D	IN9	90° joint	/	T6	ptfe hose 04/06T
			6A	RS	drain tap	12C	IFC	short insert	/	T7	silicone hose 04/06T