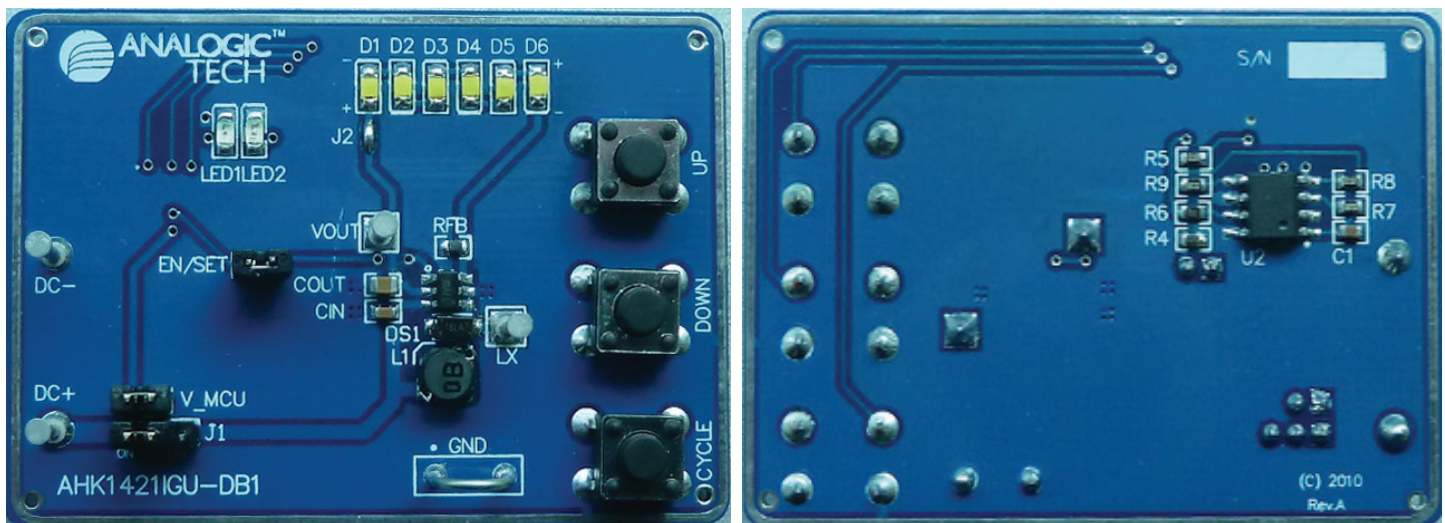

AHK1421 EVAL:
S²Cwire Controlled, Serial LED Boost Driver
Introduction

The AHK1421 evaluation board demonstrates functionality of the AHK1421 and its application as a white LED backlight driver under AnalogicTech's S²Cwire serial digital interface control.

The AHK1421 is a high frequency, high efficiency, constant-current boost converter driving six white LEDs in series configuration. The input voltage is 2.7V to 5.5V, which is ideal for portable devices powered by single-cell lithium-ion/polymer (Li-ion) batteries. The maximum LED current is set by an external resistor from 10 to 31mA. The AHK1421 is programmable with the S²Cwire interface, using an onboard microcontroller which is capable of brightening and dimming the LEDs in 32 discrete steps.

This document describes the evaluation board and its accompanying user interface. A brief "Getting Started" section is included to help the user to begin operating the evaluation board.

Board Pictures

(a) Top
(b) Bottom
Figure 1: AHK1421 Evaluation Board

AHK1421 EVAL:

S²Cwire Controlled, Serial LED Boost Driver

Board Schematic

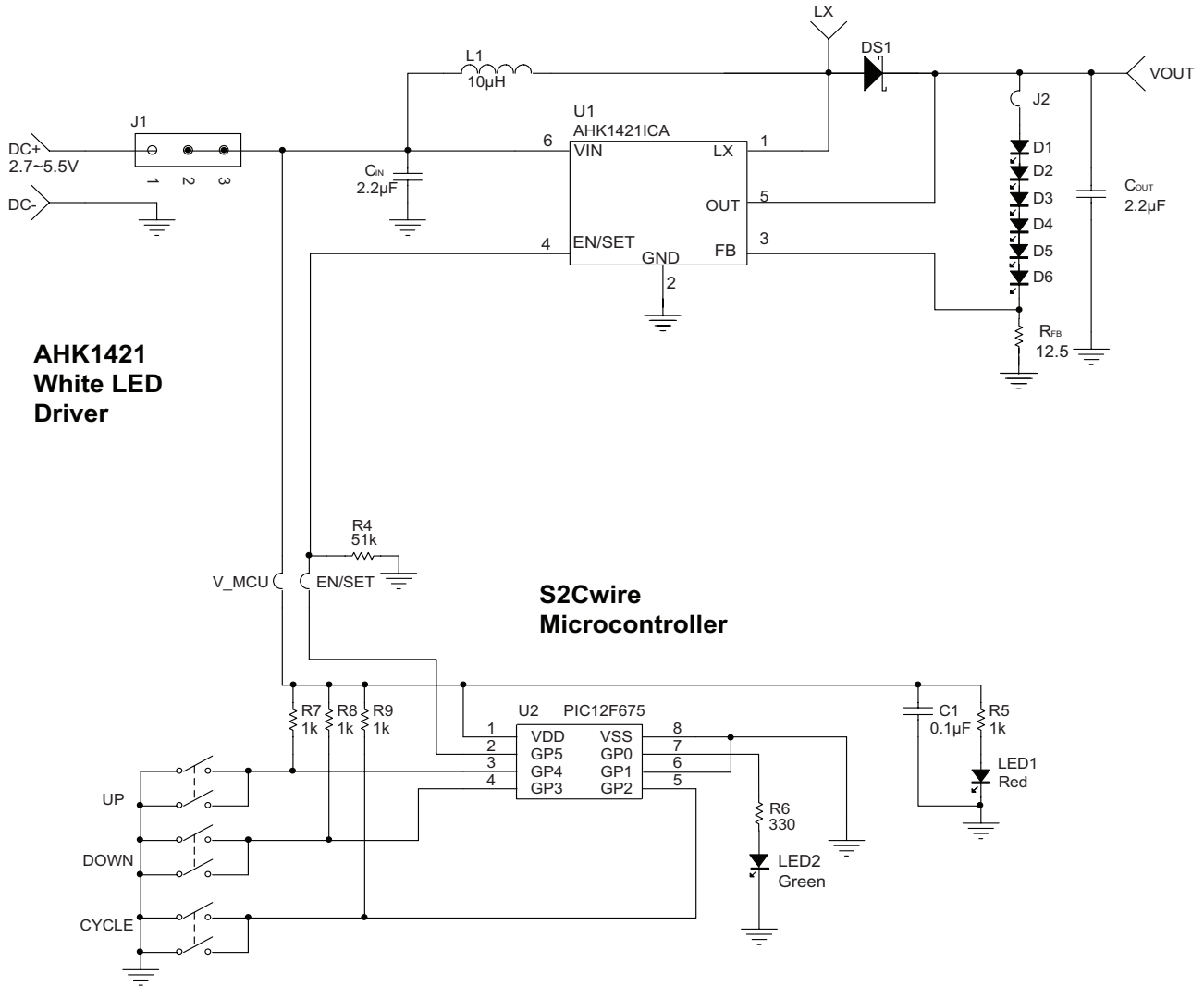
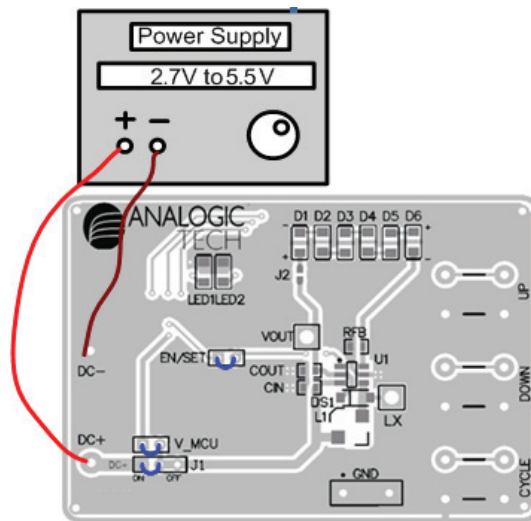

Figure 2: AHK1421 Evaluation Board Schematic

AHK1421 EVAL:
S²Cwire Controlled, Serial LED Boost Driver
Getting Started
Setup (Figure 3)

1. Connect an input power source (to supply between 2.7V and 5.5V) to the board by placing the jumper, J1 on the left (Connects DC+ power to AHK1421).
2. Connect the DC+ power to the microcontroller VDD by using the jumper V_MCU.
3. Connect the EN/SET jumper to connect the microcontroller GPIOs to the AHK1421 EN/SET pins.
4. After all jumpers are in the correct position, apply power between 2.7V and 5.5V to the DC+ and DC- terminals to power on the AHK1421 (U1) and microcontroller (U2). The red LED (LED1) will illuminate when the microcontroller is powered. The green LED (LED2) will flicker when the three buttons to transfer S²C wire data for AHK1421 are operated.
5. Use the UP, DOWN and CYCLE buttons to vary the brightness of the 6 white LEDs using the EN/SET serial data S²Cwire interface

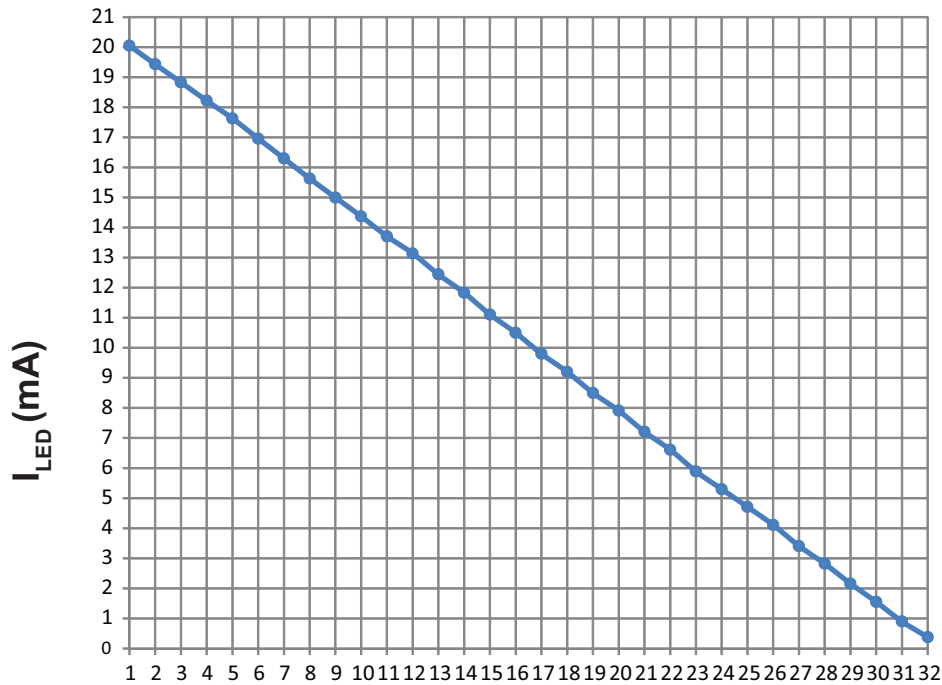

Figure 3: AHK1421 Evaluation Board Measurement Configuration
S²Cwire Control

Short the EN/SET jumper to receive S²Cwire data generated by the microcontroller according to the status of the three buttons. The AHK1421 records the number of rising edges which control output current in EN/SET pin and change the value of output current from 20mA to 0.4mA when RFB is 12.5Ω

- UP button: The UP button increments the number of EN/SET rise edges from 1 to 32 each time this button is pushed. By holding down the button for more than 0.6 seconds, the microcontroller enters auto-increment mode. The LED will dim and wrap back after S²C wire data reaches 32.
- DOWN button: The DOWN button decrements the number of EN/SET rise edges from 32 to 1 each time this button is pushed. By holding down the button for more than 0.6 seconds, the microcontroller enters auto-decrement mode. The LED will brighten and wrap back after S²Cwire data reaches 1.
- CYCLE button: The button increments or decrements the number of EN/SET edges automatically and cyclically after a single push according to the previous EN edges up or down event.
- UP+DOWN+CYCLE button: EN/SET is set to 0V and the AHK1421 is shut down. All white LEDs are turned off.

AHK142I EVAL:

S²Cwire Controlled, Serial LED Boost Driver



S²Cwire Data

Figure 4: S²Cwire Dimming Control at Maximum LED Current (20mA max)

User Interface Functionality

Button(s)	Action	Effect
UP	Push/Release once	Increment the number of EN/SET edge; Toggles through the available dimming level settings for the backlighting section.
	Push Hold 0.6 sec.+	Auto-increment the number of EN/SET edges up to 32 then wrap back to 1.
DOWN	Push/Release once	Decrement the number of EN/SET edge; Toggles through the available brightness level settings for the backlighting section.
	Push Hold 0.6 sec.+	Auto-decrement the number of EN/SET edges down to 1 then wrap back to 32
CYCLE	Push/Release once or Push Hold 0.6 sec.+	Auto-cycle in direction last set
UP+DOWN+CYCLE	Push All Three and Hold	Shut down

Table 1: User Interface Functionality

AHK1421 EVAL:**S²Cwire Controlled, Serial LED Boost Driver**

Functional Testing and Evaluation

Operational Waveform

Figure 5 shows the waveform controlled by S²Cwire at 3.6V V_{IN} when the code changes from 32 to 1. The I_{LED} changes from 0.4mA (2% I_{MAX}) to 20mA (I_{MAX}).

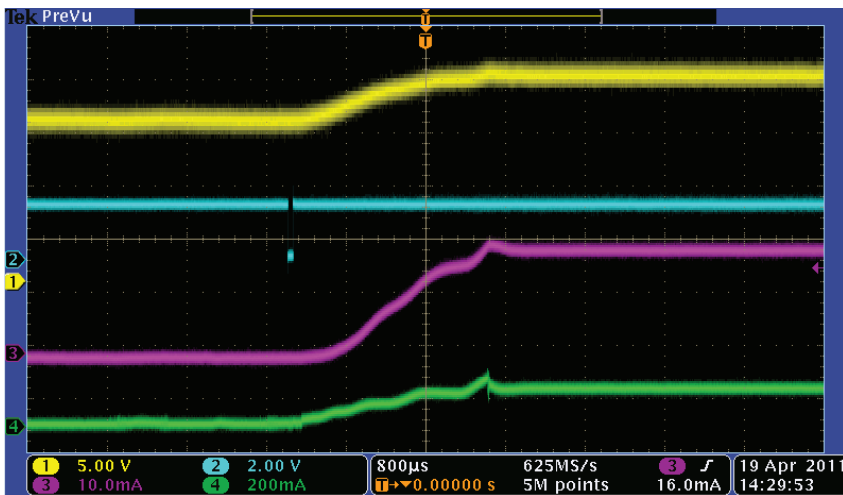

Channel	Signal
1	V _{OUT}
2	EN/SET
3	I _{LED}
4	I _{IN}

Figure 5: Operational Waveform under S²Cwire Control.

Start up

Figure 6 shows the AHK1421 startup waveform after adding rising edge on EN/SET. Soft start control makes the input current rise slowly.

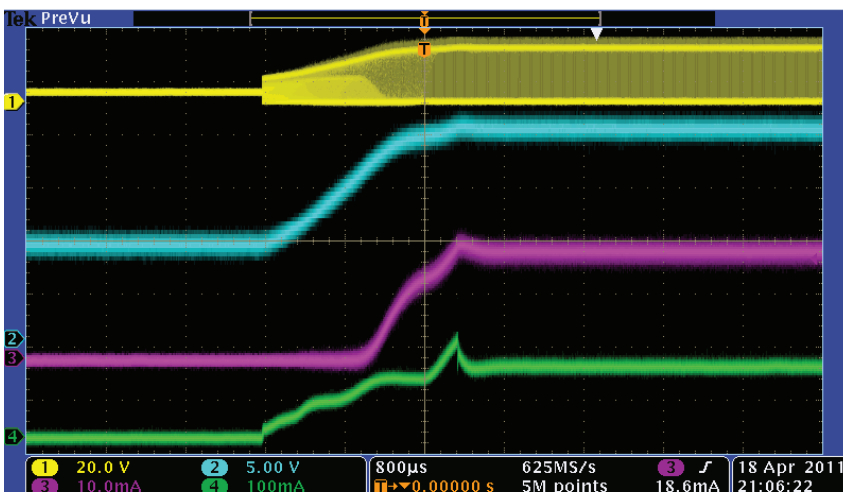

Channel	Signal
1	SW
2	V _{OUT}
3	I _{LED}
4	I _{IN}

Figure 6: Start Up Waveform.

AHK1421 EVAL:

S²Cwire Controlled, Serial LED Boost Driver

Efficiency Curves

Figure7 shows that the maximum efficiency is about 85% under 4.2V input voltage. Consult the AHK1421 product datasheet about the external diode selection.

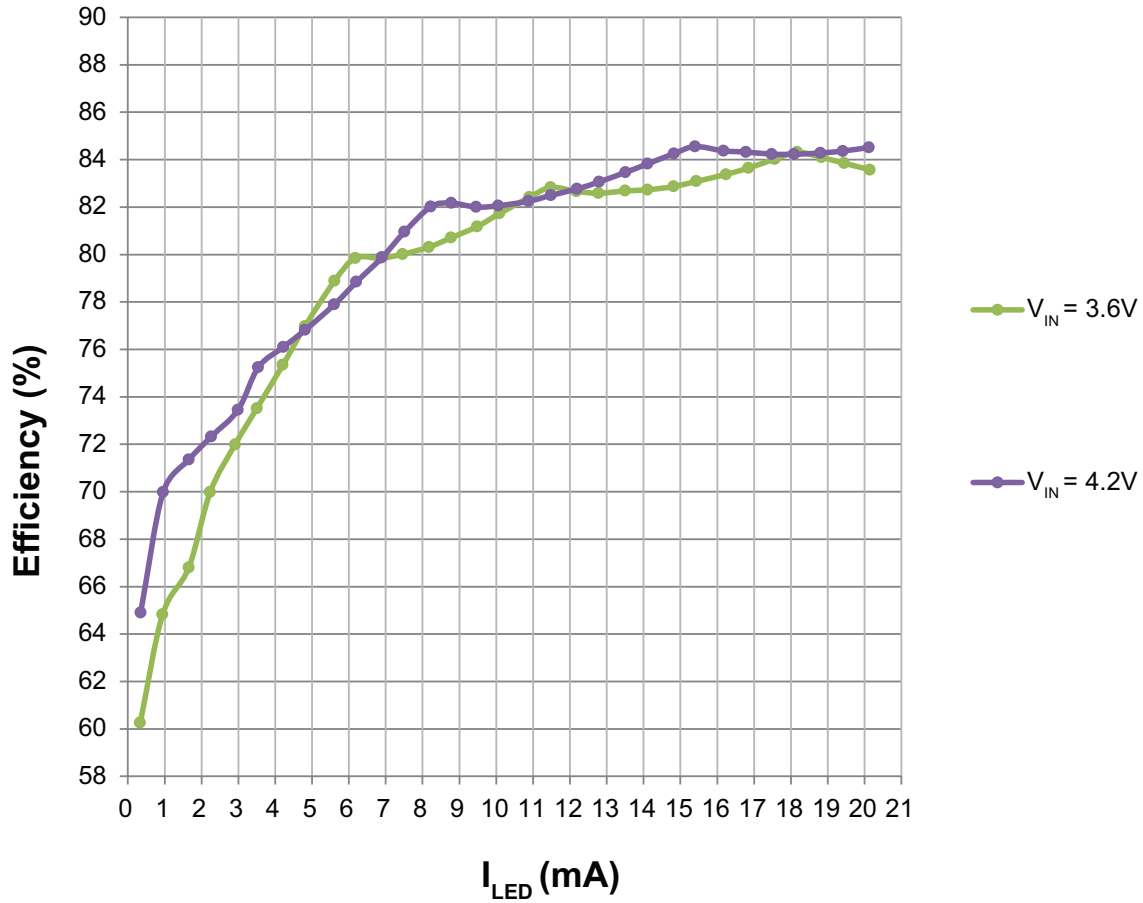
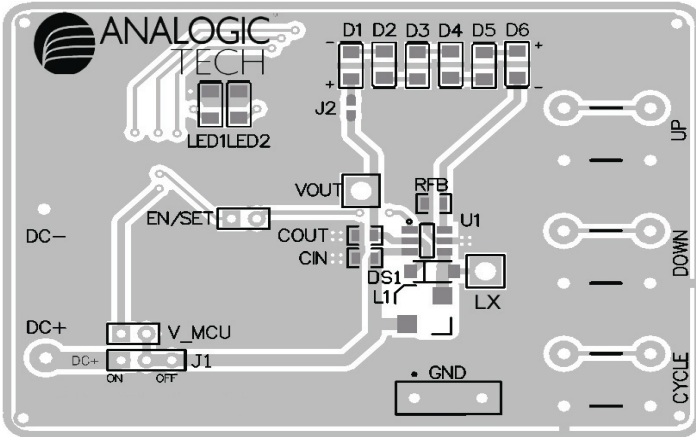
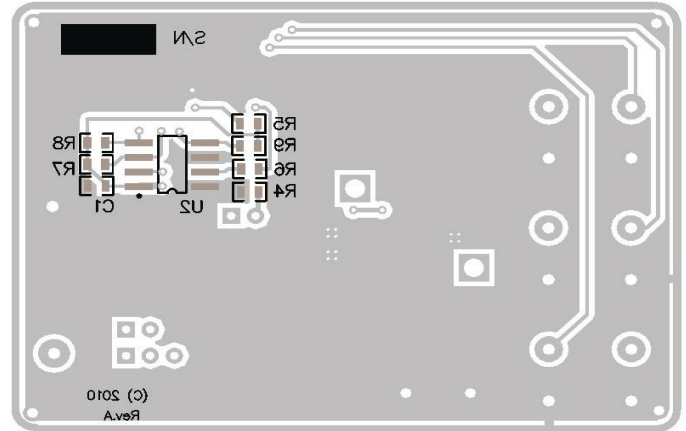

Figure 7: Efficiency Curve Waveforms.

AHK1421 EVAL:
S²Cwire Controlled, Serial LED Boost Driver
Printed Circuit Board

(a) Top

(b) Bottom
Figure 8: AHK1421 Evaluation Board (not to Scale)
AHK1421 EVAL Board Component Listing

Component	Part Number	Description	Manufacturer
U1	AHK1421ICA	S2C controlled, serial LED boost driver IC, TSOT23-6	AnalogicTech
U2	PIC12F675	8-bit CMOS, FLASH-Based uC;SOIC-8	Microchip
R6	Chip RES	RES 330Ω 1/4W 1% 0603 SMD	Yageo
R _{FB}		RES 12.5Ω 1/4W 1% 0603 SMD	
R5, R7, R8, R9		RES 1KΩ 1/4W 1% 0603 SMD	
R4		RES 51KΩ 1/4W 1% 0603 SMD	
CIN	GRM188R60J225KE01	Cap 2.2μF 0603 X5R 10V 10%	Murata
COUT	GRM21BR61H225KA73L	Cap 2.2μF 0805 X7R 50V 10%	
C1	GRM188R71C104K	Cap 0.1uF 0603 X7R 16V 10%	
D1, D2, D3, D4, D5, D6	RS-0805UW	20mA White LED 0805	Realstar
DS1	SS14L	1.0AMP.Surface Mount Schottky Barrier Rectifiers	TSC
L1	CDRH2D14-100	POWER INDUCTOR 10μH SMD	Sumida
LED1	0805KRCT	Red LED 0805	HB
LED2	0805KGCT	Green LED 0805	
CYCLE, UP, DOWN	6*6*5	12V 50mA Push button	E-LT

Table 2: AHK1421 Evaluation Board Bill of Materials.

AHK1421 EVAL:

S²Cwire Controlled, Serial LED Boost Driver

Advanced Analogic Technologies, Inc.
3230 Scott Boulevard, Santa Clara, CA 95054
Phone (408) 737-4600
Fax (408) 737-4611



© Advanced Analogic Technologies, Inc.
AnalogicTech cannot assume responsibility for use of any circuitry other than circuitry entirely embodied in an AnalogicTech product. No circuit patent licenses, copyrights, mask work rights, or other intellectual property rights are implied. AnalogicTech reserves the right to make changes to their products or specifications or to discontinue any product or service without notice. Except as provided in AnalogicTech's terms and conditions of sale, AnalogicTech assumes no liability whatsoever, and AnalogicTech disclaims any express or implied warranty relating to the sale and/or use of AnalogicTech products including liability or warranties relating to fitness for a particular purpose, merchantability, or infringement of any patent, copyright or other intellectual property right. In order to minimize risks associated with the customer's applications, adequate design and operating safeguards must be provided by the customer to minimize inherent or procedural hazards. Testing and other quality control techniques are utilized to the extent AnalogicTech deems necessary to support this warranty. Specific testing of all parameters of each device is not necessarily performed. AnalogicTech and the AnalogicTech logo are trademarks of Advanced Analogic Technologies Incorporated. All other brand and product names appearing in this document are registered trademarks or trademarks of their respective holders.