



Chunghwa Picture Tubes, Ltd. Technology Specification

To : HAU DISPLAY

Date : 130516

TFT LCD

CLAA062LA01CW

ACCEPTED BY : V0.9

APPROVED BY	CHECKED BY	PREPARED BY
黃奕凱	周國慶	陳威

Prepared by :

**Medium Product Planning Management General Division
Product Planning Management Center
CHUNGHWA PICTURE TUBES, LTD.**

1127 Hopin Rd., Padeh, Taoyuan, Taiwan 334, R.O.C.
TEL: +886-3-3675151 FAX: +886-3-377-3858

Doc.No:	SPEC_CLAA062LA01CW_V0.9_HAU DISPLAY_130516	Issue Date:	2013/05/16
---------	--	-------------	------------

REVISION STATUS

Revision Notice	Description	Page	Rev. Date
0.0	First revision (Tentative).	--	2012.01.06
0.1	Revise Temperature Specification.	P.5	2012.02.21
	Revise Typical Operation Conditions.	P.6	
	Revise Power · Signal sequence.	P.7	
	Revise Timing Characteristics of input signals.	P.8~9	
0.2	Revise Total Module Power(W).	P.4	2012.03.07
	Revise Typical Operation Conditions.	P.6	
	Revise Current consumption.	P.6	
	Revise Timing Characteristics of input signals.	P.8~9	
0.3	Revise Mechanicl Dimension.	P.14~15	2012.03.16
	Revise Color Coordinate.	P.16	
0.4	Add Module Weight.	P.4	2012.04.15
	Revise Common and Gamma Voltage.	P.6	
	Remove Frame Rate.	P.8	
	Revise Mechanic Dimension.	P.14	
0.5	Add Gamma Voltage and Circuit.	P.6	2012.05.11
0.6	Revise Pulse Forward Current.	P.5	2012.06.06
	Revise Ambient Temperature /Allowable Forward Current.	P.5	
	Revise Backlight Specification.	P.12	
	Add CN2 Specification.	P.15	
	Revise Mechanicl Dimension.	P.16	
0.7	Revise Common Voltage and Gamma Voltage	P.6	2012.08.27
0.8	Revise Common Voltage and Gamma Voltage	P.6	2012.09.12
0.9	Revise Ambient Temperature /Allowable Forward Current Chart	P.5	2012.10.09

CONTENTS

1. OVERVIEW	4
2. ABSOLUTE MAXIMUM RATINGS.....	5
3. ELECTRICAL CHARACTERISTICS	6
3.1 Typical operation conditions	6
3.2 Current consumption.....	7
3.3 Power 、 Signal sequence	7
3.4 Timing characteristics of input signals	9
3.5 Backlight.....	12
4. INTERFACE CONNECTION:	13
4.1 CN1(Signal of interface).....	13
4.2 CN2(Backlight).....	15
5. MECHANICAL DIMENSION.....	16
5.1 Front Side	16
5.2 Rear Side.....	17
6. OPTICAL CHARACTERISTICS	18
7. RELIABILITY TEST.....	21
7.1 Temperature and Humidity	21
7.2 Shock and Vibration.....	21
7.3 Electrostatic Discharge.....	21
7.4 Judgment Standard.....	22

1. OVERVIEW

CLAA062LA01CW is 6.2" color TFT-LCD (Thin Film Transistor Liquid Crystal Display) module composed of LCD panel, driver ICs, control circuit and LED backlight. By applying 800x480 images are displayed on the 6.2" diagonal screen. Display 16.2M colors by R.G.B signal input.

General specifications are summarized in the following table:

ITEM	SPECIFICATION
Number of Pixels	800RGBx480
Pixel Pitch(mm)	0.1719x0.1609
Color Pixel Arrangement	Strip RGB
Module Size(mm)	155.2 x 88.2 x 5.0
Display Area(mm)	137.52 x 77.232
Module Weight(g)	115 g(Typ.)
Brightness(cd/m ²)	450(Typ.)/360(Min.)
Contrast Ratio	min. 480 typ. 600
Response Tims(ms)	16(Max.)
Viewing Angle(H/V)--CR>10	150/140
Color Saturation	50%
Color Coordinate-White	x=0.310, y=0.330
Display Mode	TN
Surface Treatment	Anti-Glare
Luminance Uniformity(Δ LW)	min.70% (9 points)
Optimum Viewing Direction	6 O'clock
Electrical Interface	TTL(Cascade), 60pin
Inversion	dot Inversion
Total Module Power(W)	PLCD=0.321W (typ)/ 0.396 W (max); PLED=1.17 W typ.)/1.3W(max.) Total:1.491W (typ)/1.696W (max)
Number of Colors	16.2M

2. ABSOLUTE MAXIMUM RATINGS

Item	Symbol	Min.	Max.	Unit	Note
Digital Supply Voltage	DVDD	-0.3	+5.0	V	
Analog Supply Voltage	AVDD	-0.5	+15	V	
Gate On Voltage	VDDG	-0.3	+40	V	
Gate Off Voltage	VEEG	-20	+0.3	V	
Gate On-Gate Off Voltage	VDDG-VEEG	-0.3	40	V	
Forward Current (per LED)	If	-	30	mA	
Reverse Voltage (per LED)	VR	-	5	V	
Pulse forward current (per LED)	I _{fp}	-	80	mA	1,2
Operation Temperature	T _{op}	-20	70	°C	3
Storage Temperature	T _{stg}	-30	80	°C	3

Note1 : I_{fp} Conditions : Pulse Width ≤ 10msec ; Duty ≤ 1/10

Note2: Each LED operating must under the condition as below drawing.
(Ambient Temperature /Allowable Forward Current)

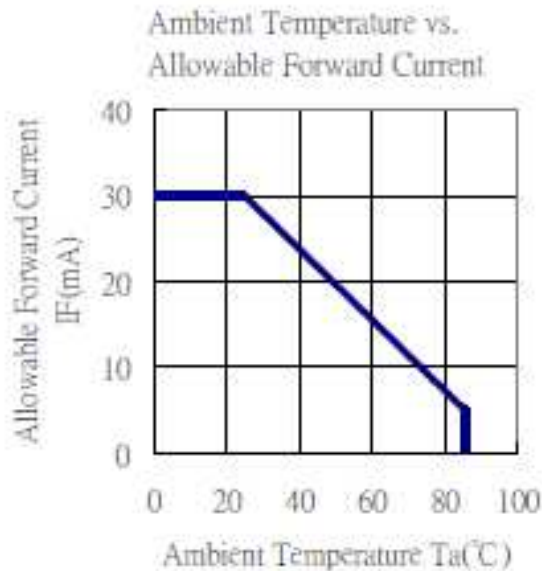

Note3 : If users use the product out off the environmental operation range (temperature and humidity) , it will have visual quality concerns.

3. ELECTRICAL CHARACTERISTICS

3.1 Typical operation conditions

Ta=25°C

Item	Symbol	Min.	Typ.	Max.	Unit.	Note.
Digital Supply Voltage	DVDD	3	3.3	3.6	V	
Analog Supply Voltage	AVDD	9.0	9.2	9.4	V	
Gate On Voltage	VDDG	17	18	19	V	
Gate Off Voltage	VEEG	-6.6	-6	-5.4	V	
Common Voltage	VCOM	3.8	4	4.2	V	1
Gamma Voltage	VR 1	-	9.01	-	V	2
	VR 2	-	7.22	-	V	2
	VR 3	-	6.88	-	V	2
	VR 4	-	6.57	-	V	2
	VR 5	-	5.525	-	V	2
	VR 6	-	3.925	-	V	2
	VR 7	-	2.854	-	V	2
	VR 8	-	2.484	-	V	2
	VR 9	-	2.04	-	V	2
	VR 10	-	0.21	-	V	2
Logic Input Voltage	VIH	0.7DVDD	-	DVDD	V	
	VIL	GND	-	0.3DVDD	V	

Note1 : Please adjust VCOM to make the flicker level be minimum.

Note2 : Gamma circuit for reference only

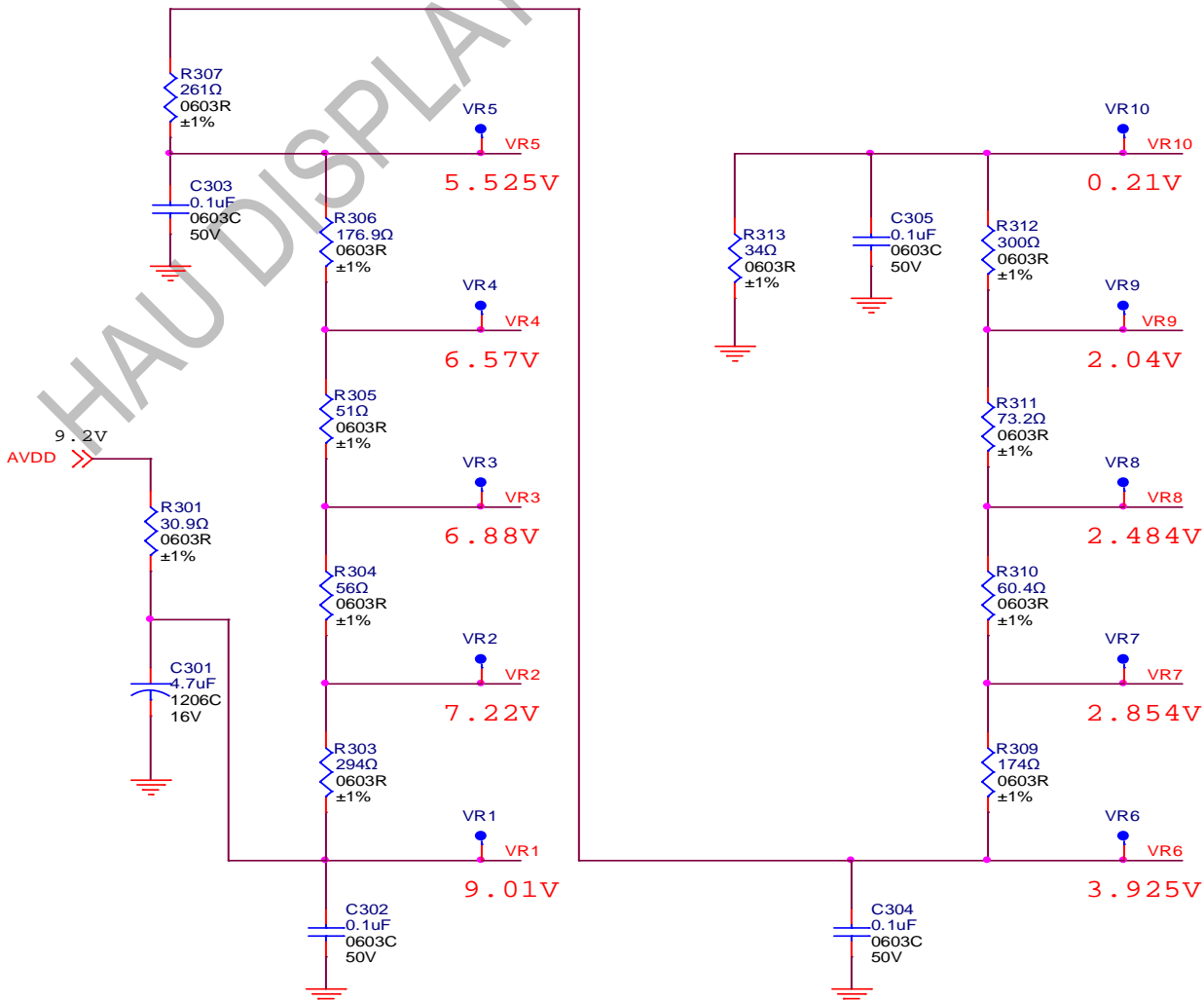

3.2 Current consumption

Item	Symbol	Condition	Min.	Typ.	Max.	Unit.	Note.
Gate on Current	IVDDG	VDDG = 18 V	-	0.5	1	mA	1
Gate off Current	IVEEG	VEEG = -6 V	-	0.5	1	mA	1
Digital Current	IDVDD	DVDD = 3.3V	-	10	15	mA	1
Analog Current	IAVDD	AVDD = 9.2 V	-	30	35	mA	1
Total Power Consumption	PC		-	321	396	mW	1

Note1: Typ. specification : Gray-level test Pattern
 Max. specification : Black test Pattern



(a) Gray-level Pattern



(b) Black Pattern

3.3 Power · Signal sequence

Power On : DVDD → AVDD/VEEG → VDDG → Video & Logic Signal → Backlight

Power Off : Backlight → Video & Logic Signal → VDDG → AVDD/VEEG → DVDD

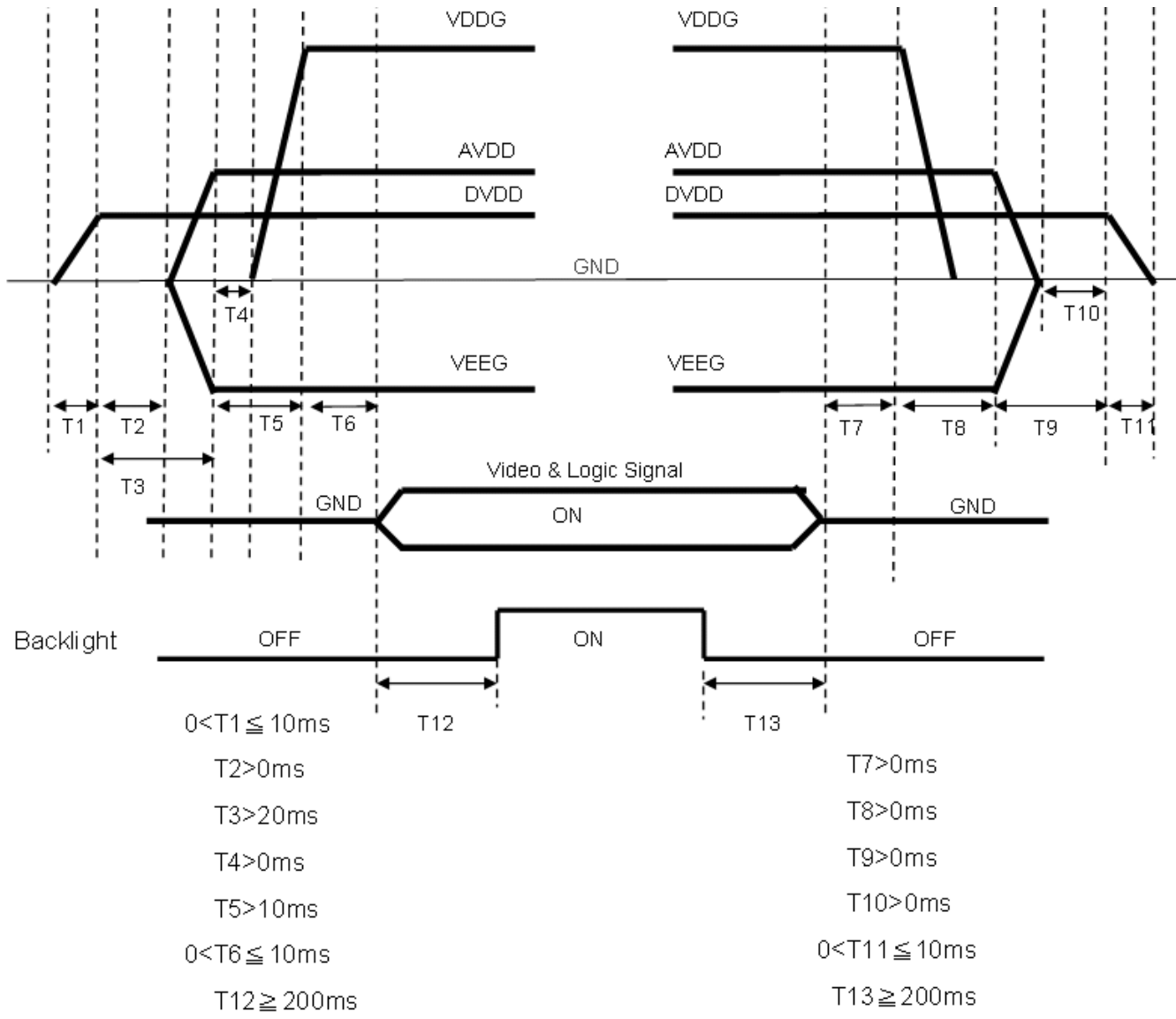

HAU DI

3.4 Timing characteristics of input signals

ITEM		SYMBOL	MIN.	TYP.	MAX.	UNIT	Note
DCLK	Dot Clock	$1/t_{CLK}$	26	30	35	MHz	
	DCLK pulse duty	T_{cwh}	40	50	60	%	
DE	Setup Time	T_{esu}	8	-	-	ns	
	Hold time	T_{ehd}	8	-	-	ns	
	Horizontal Period	t_H	908	928	1000	t_{CLK}	
	Horizontal Valid	t_{HA}	800				
	Horizontal Blank	t_{HB}	108	128	200	t_{CLK}	
	Vertical Period	t_V	515	525	700	t_H	
	Vertical Valid	t_{VA}	480				
	Vertical Blank	t_{VB}	35	45	220	t_H	
	SYNC	HSYNC Setup Time	T_{hst}	8	-	-	ns
HSYNC Hold Time		T_{hhd}	8	-	-	ns	
VSYNC Setup Time		T_{vst}	8	-	-	ns	
VSYNC Hold Time		T_{vhhd}	8	-	-	ns	
Horizontal Period		t_h	908	928	1000	t_{CLK}	
Horizontal Pulse Width		t_{hpw}	-	48	-	t_{CLK}	$t_{hb} + t_{hpw} = 88DCLK$ is fixed
Horizontal Back Porch		t_{hb}	-	40	-	t_{CLK}	
Horizontal Front Porch		t_{hfp}	20	40	112	t_{CLK}	
Horizontal Valid		t_{hd}	800				
Vertical Period		t_v	515	525	700	t_h	
Vertical Pulse Width		t_{vpw}	-	3	-	t_h	$t_{vpw} + t_{vb} = 32t_h$ is fixed
Vertical Back Porch		t_{vb}	-	29	-	t_h	
Vertical Front Porch		t_{vfp}	3	13	188	t_h	
Vertical Valid		t_{vd}	480				
DATA	Setup Time	T_{dsu}	8	-	-	ns	
	Hold Time	T_{dhd}	8	-	-	ns	

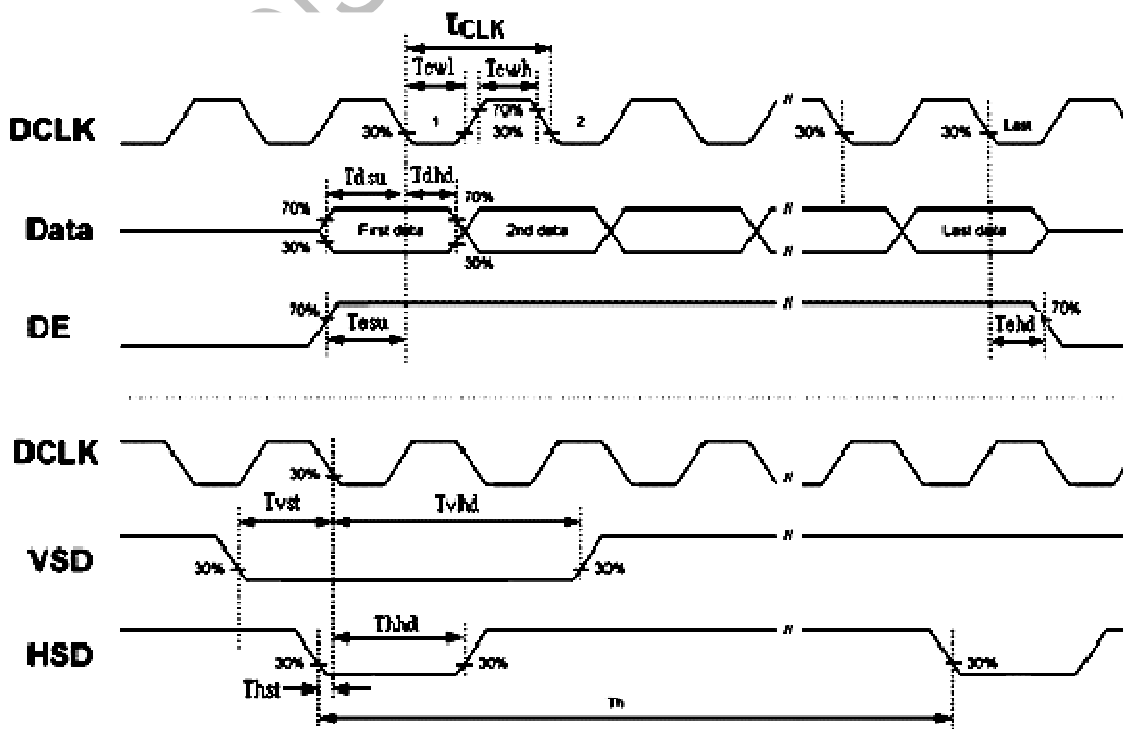

DE mode

Horizontal timing :

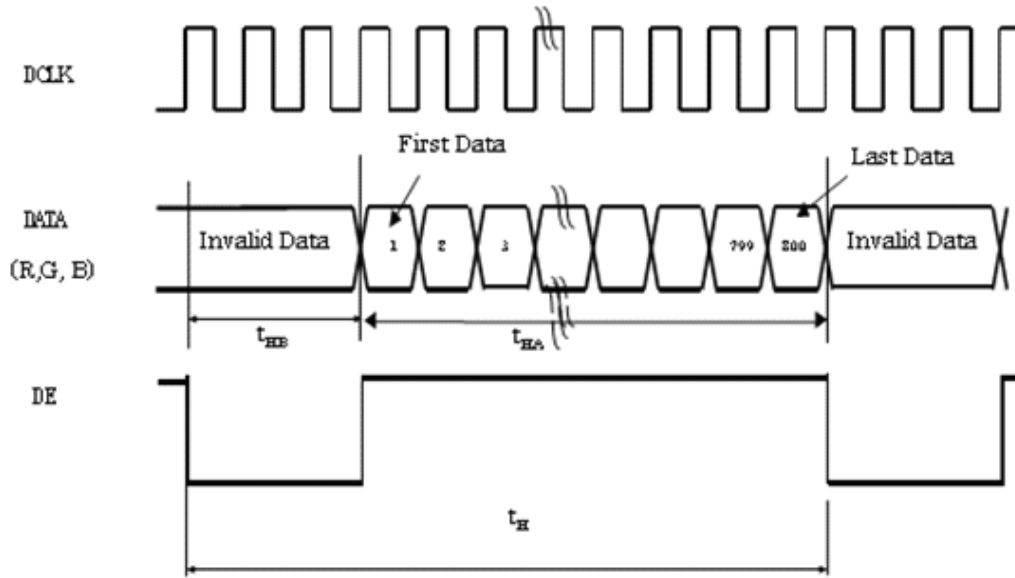

Vertical timing :

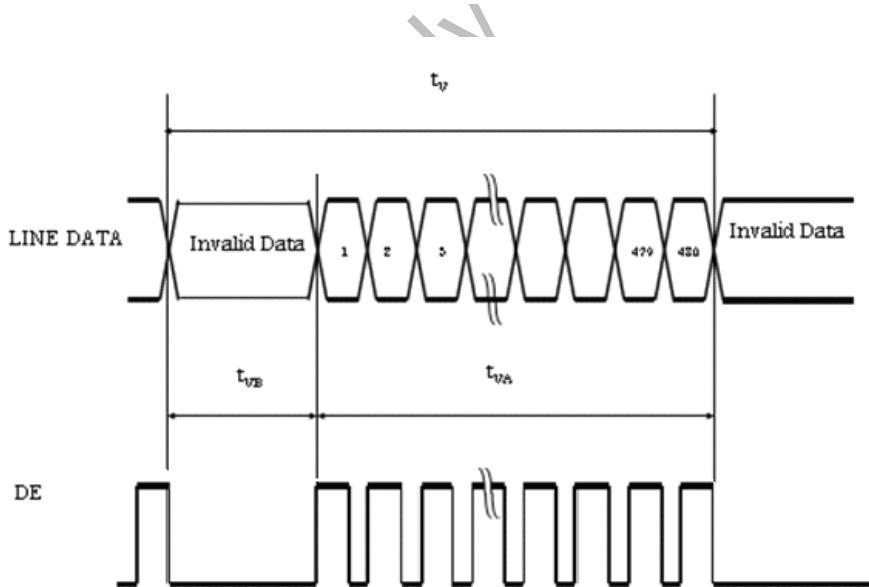

SYNC mode

Horizontal timing :

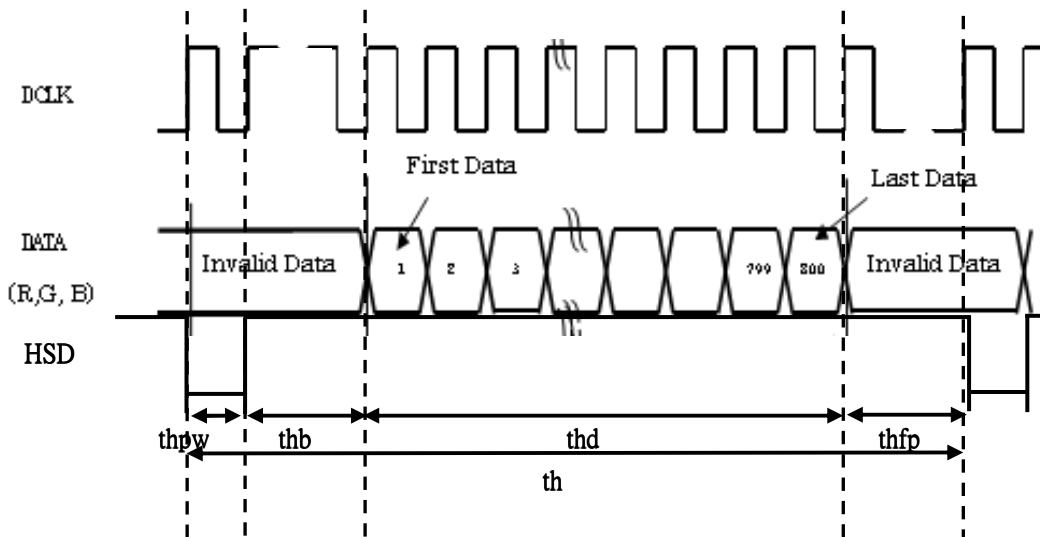

Vertical timing :

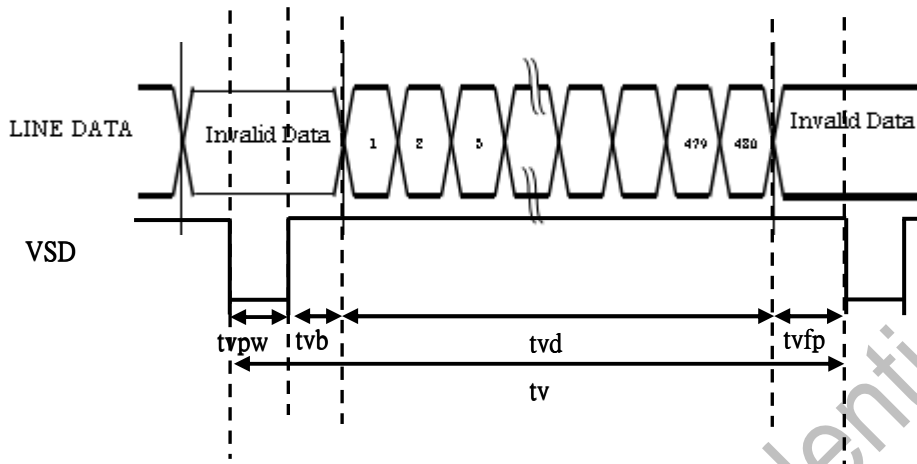

HAU DISPLAY Only Confidential

3.5 Backlight

Ta=25°C

ITEM	SYMBOL	CONDITION	MIN.	TYP.	MAX.	UNIT	Note
LED current	IL	Ta=25°C Each serial=20mA	-	120	-	mA	1,2,3
LED voltage	VL	Ta=25°C Each serial=20mA	8.55	9.6	10.65	V	1,2,3
Power consumption	WL	Ta=25°C Each serial=20mA	-	1.152	-	W	1,2
LED Lifetime	-	Ta=25°C Each serial=20mA	30000			Hour	4

Note1 : LED Circuit Diagram :

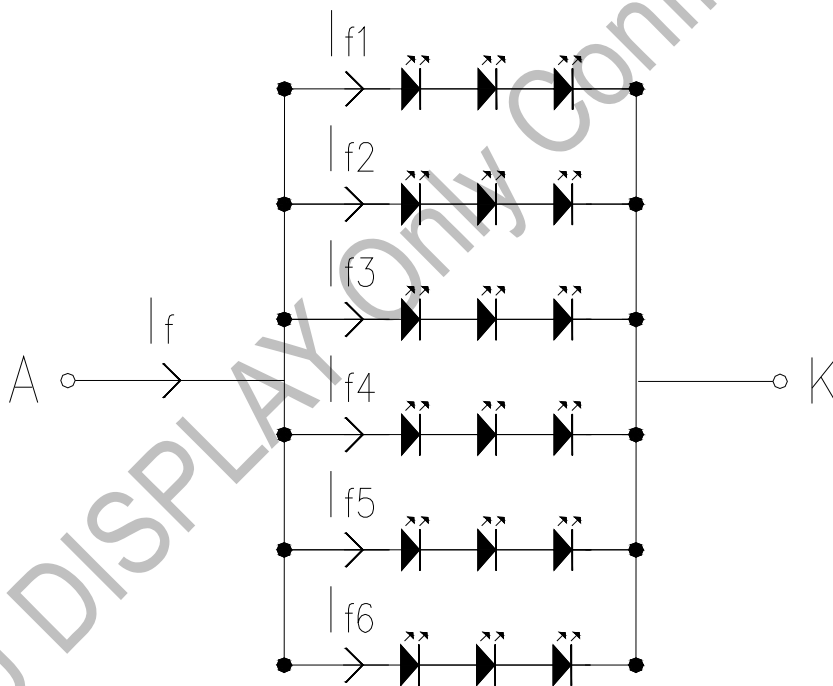

Note2 : A : Anode(+) , K : Cathode(-)

Note3 : LED control must use the constant current control to avoid the leakage light and brightness quality issue.

Note4 : Definition of the LED life time : Luminance will decay less than 50%

4. INTERFACE CONNECTION:

4.1 CN1(Signal of interface)

Pin NO.	SYMBOL	DESCRIPTION
1	AGND	Analog Ground
2	AVDD	Analog Power
3	DVDD	Digital Power
4	R0	Data Input(LSB)
5	R1	Data Input
6	R2	Data Input
7	R3	Data Input
8	R4	Data Input
9	R5	Data Input
10	R6	Data Input
11	R7	Data Input(MSB)
12	G0	Data Input(LSB)
13	G1	Data Input
14	G2	Data Input
15	G3	Data Input
16	G4	Data Input
17	G5	Data Input
18	G6	Data Input
19	G7	Data Input(MSB)
20	B0	Data Input(LSB)
21	B1	Data Input
22	B2	Data Input
23	B3	Data Input
24	B4	Data Input
25	B5	Data Input
26	B6	Data Input
27	B7	Data Input(MSB)
28	DCLK	Clock input
29	DE	Data Enable signal
30	HSD	Horizontal sync input. Negative polarity
31	VSD	Vertical sync input. Negative polarity
32	MODE	DE/SYNC mode select. Normally pull high H: DE mode. L: HSD/VSD mode
33	RSTB	Global reset pin. Active low to enter reset state. Suggest to connecting with an RC reset circuit for stability. Normally pull high. (R=47K Ω , C=1 μ)
34	STBYB	Standby mode, normally pull high STBYB="1", normal operation STBYB="0", timing control, source driver will turn off, all output are high-Z
35	SHLR	Left or Right Display Control
36	DVDD	Digital Power
37	UPDN	Up / Down Display Control
38	GND	Digital Ground
39	AGND	Analog Ground
40	AVDD	Analog Power
41	VCOM	Common Voltage
42	DITH	Dithering setting DITH="H" 6bit resolution(last 2 bit of input data truncated) (default setting) DITH="L" 8bit resolution
43	NC	Not connect
44	NC	Not connect
45	V10	Gamma correction voltage reference
46	V9	Gamma correction voltage reference
47	V8	Gamma correction voltage reference
48	V7	Gamma correction voltage reference
49	V6	Gamma correction voltage reference
50	V5	Gamma correction voltage reference

51	V4	Gamma correction voltage reference
52	V3	Gamma correction voltage reference
53	V2	Gamma correction voltage reference
54	V1	Gamma correction voltage reference
55	NC	Not connect
56	VDDG	Positive Power for TFT
57	DVDD	Digital Power
58	VEEG	Negative Power for TFT
59	GND	Digital Ground
60	NC	Not connect

Note1: Mating connector : HIROSE, FH28-60S-0.5SH, 60pin,pitch = 0.5mm

Note2: SHLR : left or right setting

UPDN : up or down setting

SHLR	UPDN	Data shifting
DVDD	GND	Left→Right , Up→Down(default)
GND	GND	Right→Left , Up→Down
DVDD	DVDD	Left→Right , Down→Up
GND	DVDD	Right→Left , Down→Up

Definition of scanning direction.

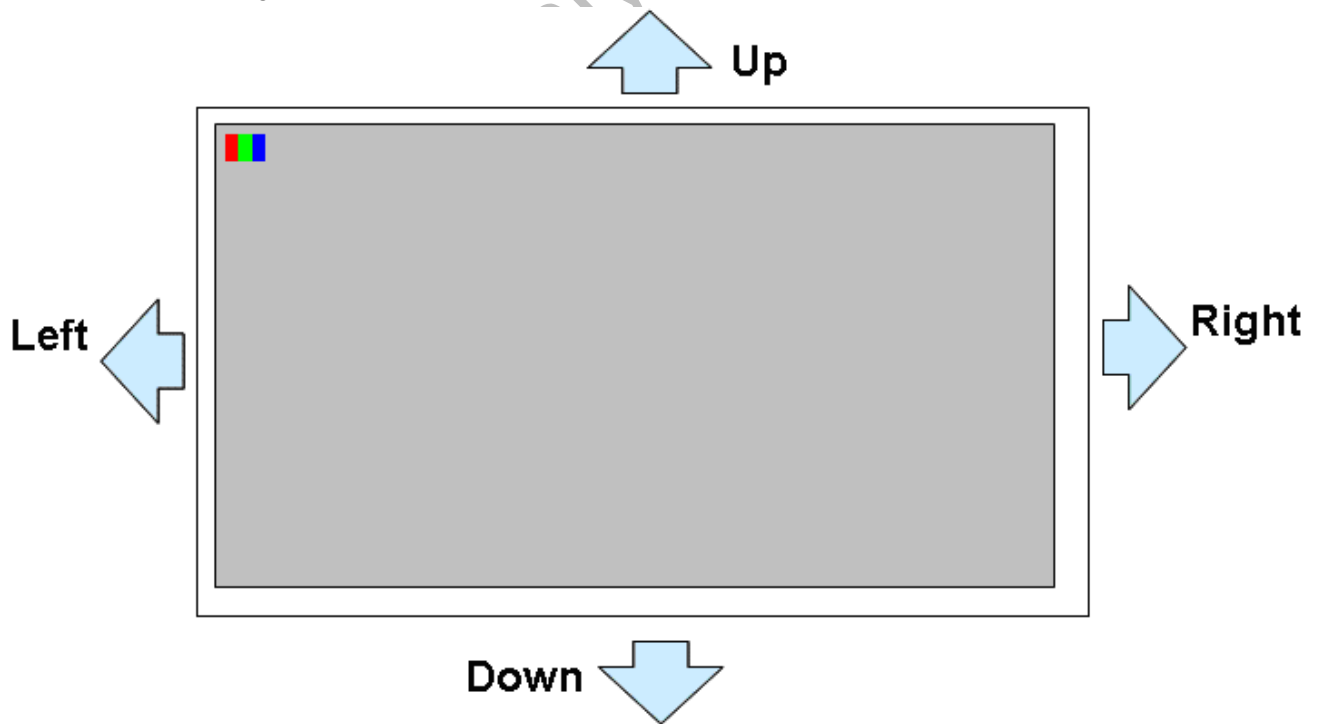

4.2 CN2(Backlight)

Input connector : BHSR-02VS-1(JST)

Outlet connector: SM02B-BHSS-1(JST)

Pin No.	Symbol	Function
1	A	Anode
2	K	Cathode

CN2 Circuit Diagram :

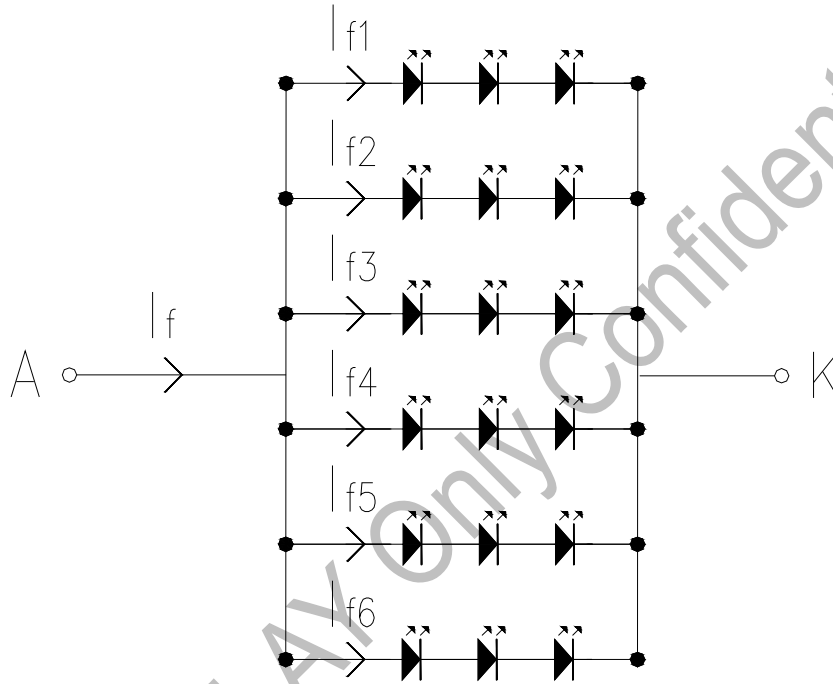

5. MECHANICAL DIMENSION

5.1 Front Side

(Unit : mm)

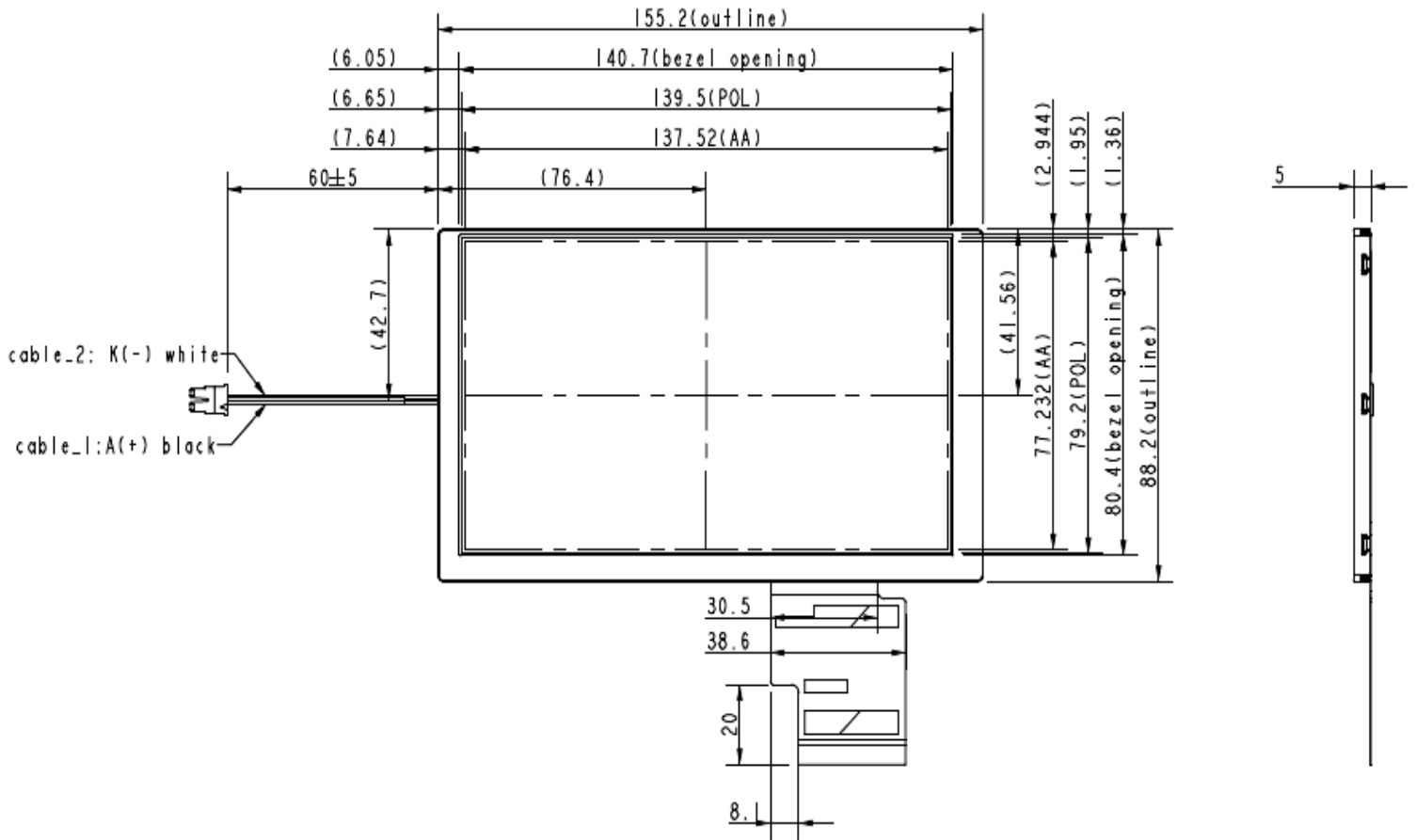
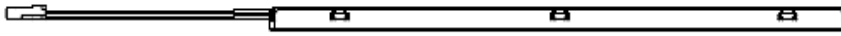

5.2 Rear Side

(Unit : mm)

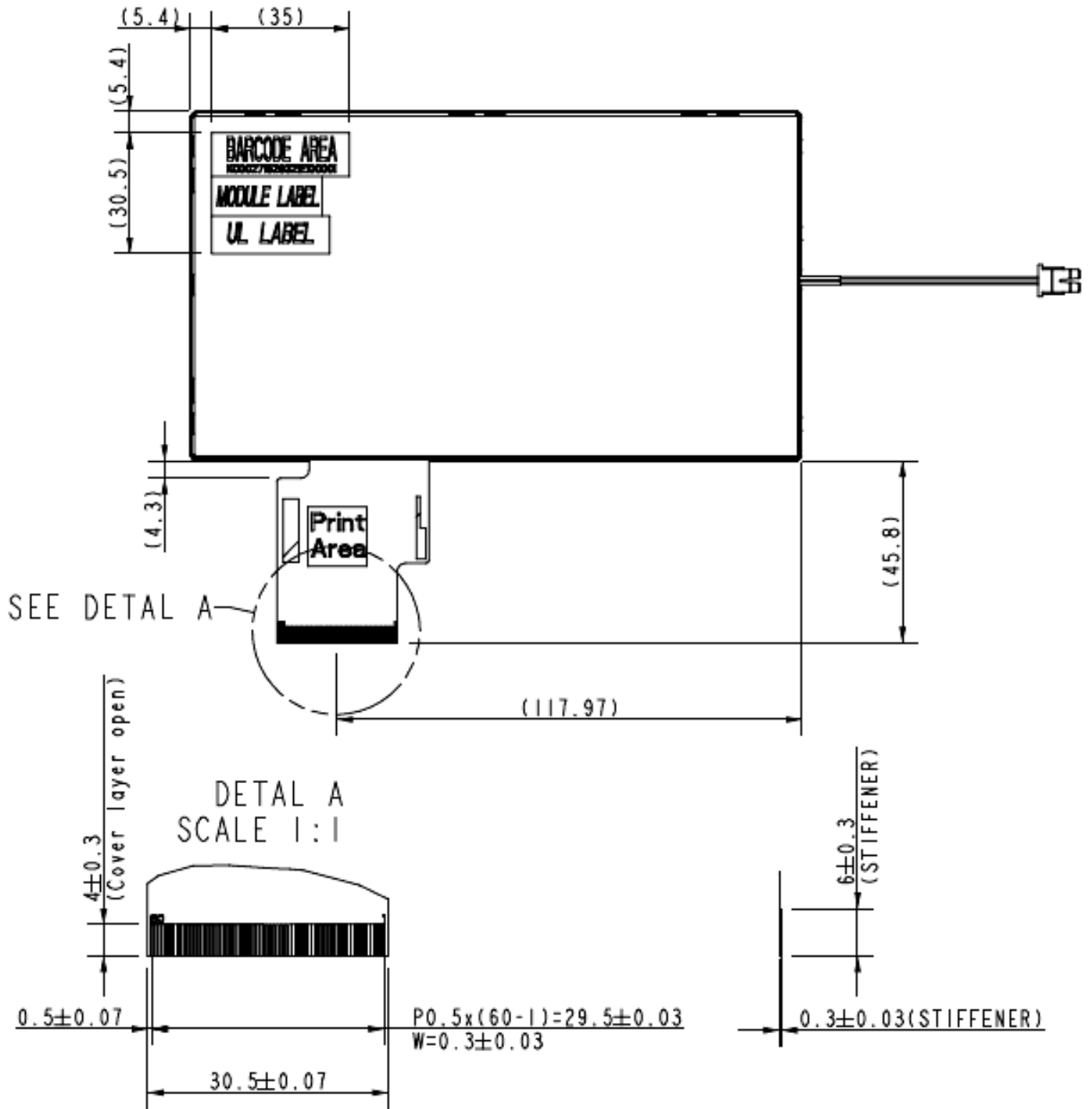

NOTE: General tolerance=±0.3mm

6. OPTICAL CHARACTERISTICS

(Use CPT LED backlight)

Ta=25°C

ITEM	SYMBOL	CONDITIONS	MIN	TYP	MAX	UNIT	NOTE
Constrast Ratio	CR	Point-5	480	600	-	--	1, 2, 3
Luminance(CEN)	Lw	Point-5	360	450	-	cd/m ²	1, 3
Luminance Uniformity	ΔL	-	70	80	-	%	1, 3
Response Time (White - Black)	Tr +Tf	Point-5	-	-	16	ms	1, 3, 5
NTSC	-	Point-5	-	50	-	%	1, 3
Viewing Angle	Horizontal	CR ≥ 10 Point-5	130	150	--	°	1, 3
	Vertical		120	140	--	°	1, 2, 4
Color Coordinate	White	$\theta = \phi = 0^\circ$	0.260	0.310	0.360	--	1, 3
			0.280	0.330	0.380		
	Red		0.551	0.601	0.651		
			0.292	0.342	0.392		
Green	Gx Gy	0.290	0.340	0.390			
		0.552	0.602	0.652			
Blue	Bx By	0.108	0.158	0.208			
		0.067	0.117	0.167			

Note1: Measure condition : 25°C ±2°C · 60±10%RH · under10 Lux in the dark room.BM-5A (TOPCON) · viewing angle2° · IL=120 mA (Backlight current) · measurement after lighting on 10 mins.

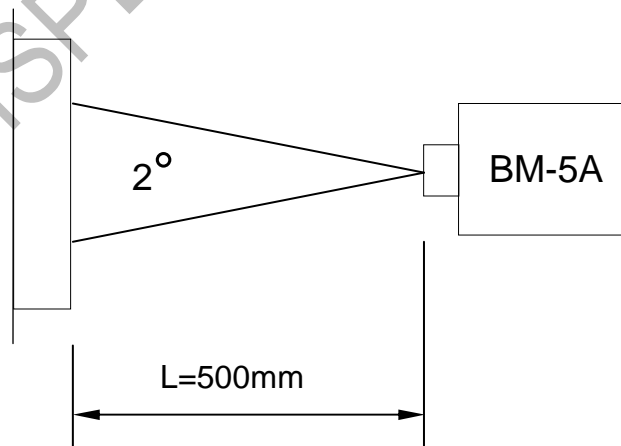

Note2: Definition of contrast ratio :

$$\text{Contrast Ratio (CR)} = (\text{White}) \text{ Luminance of ON} \div (\text{Black}) \text{ Luminance of OFF}$$

Note3: Definition of luminance : Measure white luminance on the point 5 as figure.6-1

Definition of Luminance Uniformity: Measure white luminance on the point 1~9 as figure.6-1

$$\Delta L = [L(\text{MIN})/L(\text{MAX})] \times 100$$

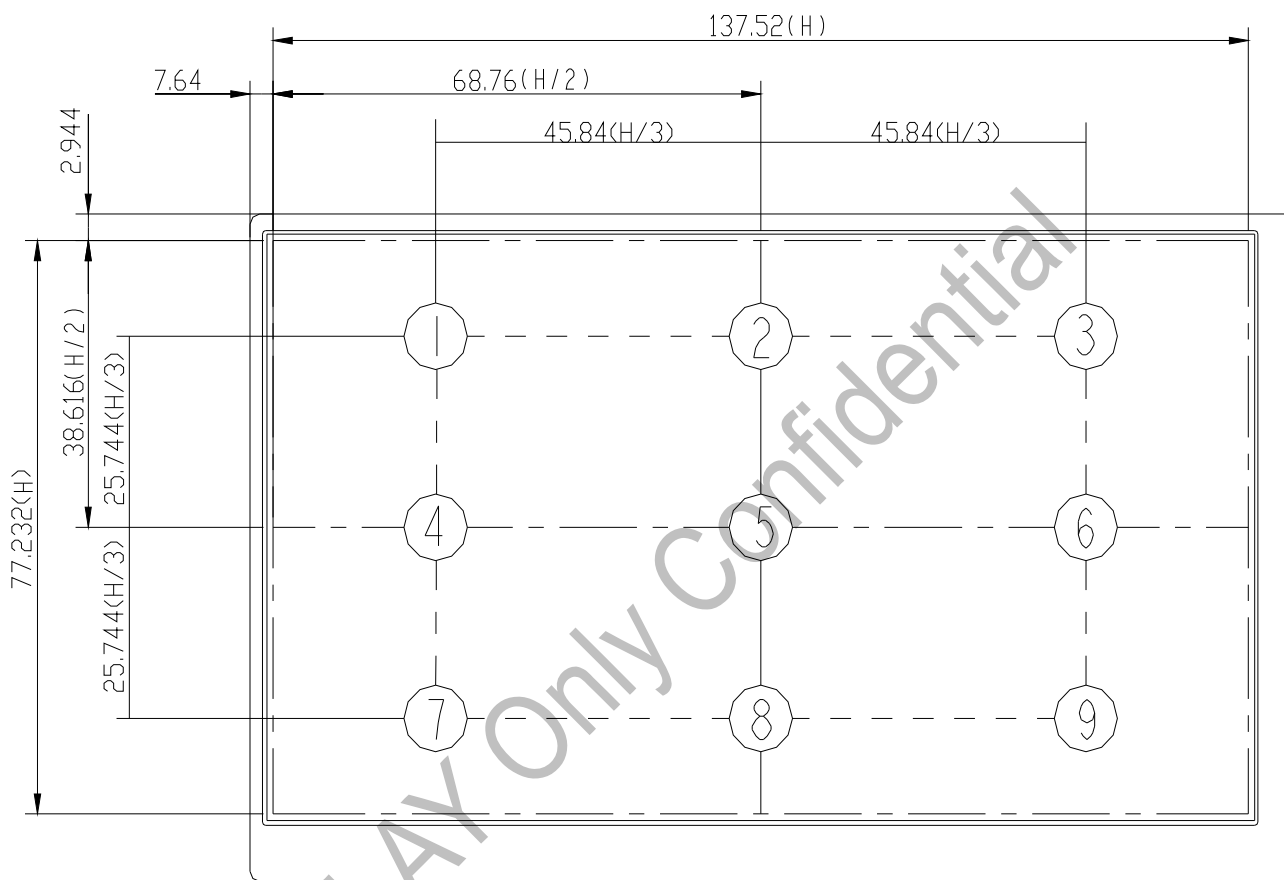

Fig.6-1 Measuring point

Note 4: Definition of Viewing Angle(θ, ψ), refer to Fig.6-2 as below :

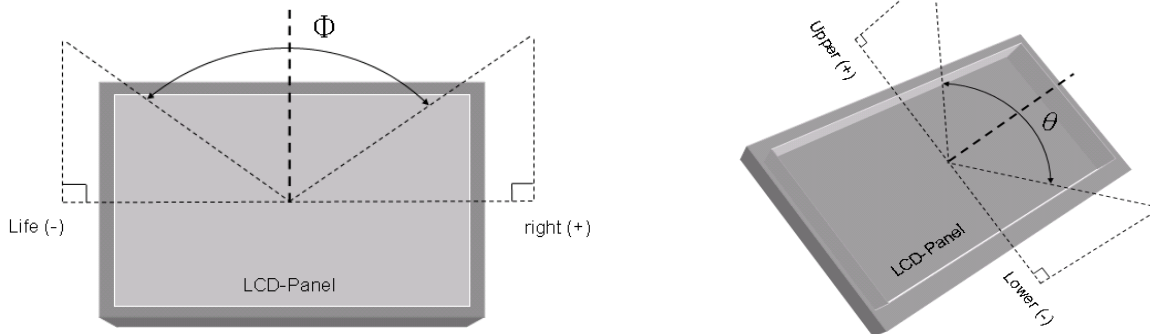

Fig.6-2 Definition of Viewing Angle

Note5: Definition of Response Time.(White-Black)

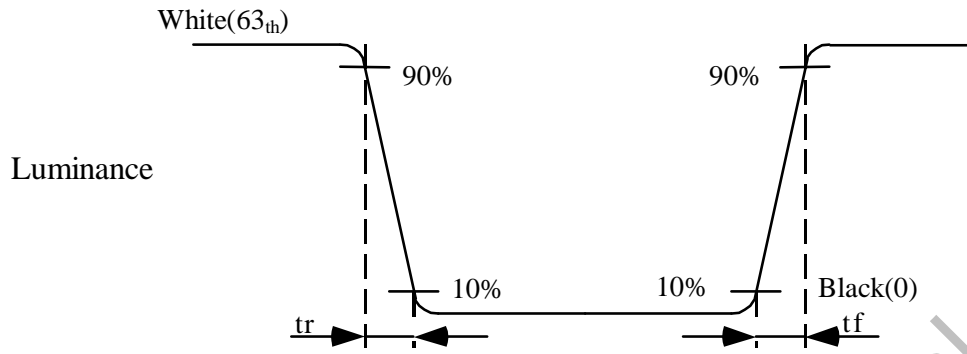

Fig.6-3 Definition of Response Time(White-Black)

HAU DISPLAY Only Confidential

7. RELIABILITY TEST

7.1 Temperature and Humidity

TEST ITEMS	CONDITIONS	NOTE
High Temperature Operation	70°C ;240hrs	
High Temperature Storage	80°C ; 240hrs	
High Temperature High Humidity Operation	60°C ; 90%RH ;240hrs	No condensation
Low Temperature Operation	-20°C ; 240hrs	Backlight unit always turn on
Low Temperature Storage	-30°C ; 240hrs	
Thermal Shock	-30°C (0.5hr) ~ 80°C (0.5hr) ; 200 Cycles	
Image Sticking	25°C ; 4hrs	

Note 1: Condition of Image Sticking test : 25 °C ± 2 °C

Operation with test pattern sustained for 4 hrs, then change to gray pattern immediately.
After 5 mins, the mura must be disappeared completely.

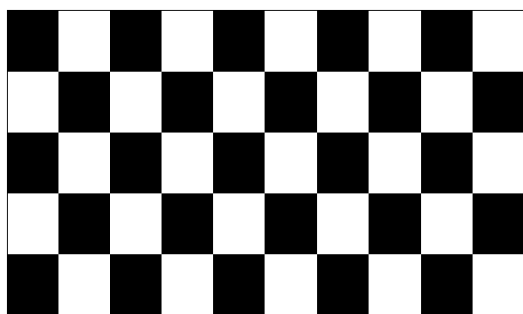

(a) Test Pattern (chess board Pattern)

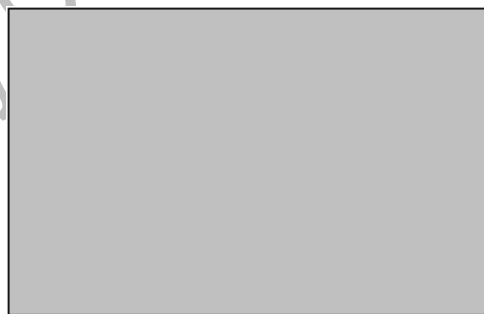

(b) Gray Pattern

7.2 Shock and Vibration

ITEMS	CONDITIONS
Shock (Non-operation)	<ul style="list-style-type: none"> ● Shock level: 980m/s²(equal to 100G). ● Waveform: half sinusoidal wave,6ms. ● Number of shocks: one shock input in each direction of three mutually perpendicular axes for a total of three shock inputs.
Vibration (Non-operation)	<ul style="list-style-type: none"> ● Frequency range:8~33.3Hz ● Stoke : 1.3 mm ● Vibration: sinusoidal wave, perpendicular axis(x, z axis: 2Hrs y axis: 4Hrs). ● Sweep: 2.9G,33.3 Hz -400 Hz ● Cycle: 15 min
Vibration Random (Non-operation)	<ul style="list-style-type: none"> ● 1.04Grms, 5~500Hz, X/Y/Z, ● 30min/each direction

7.3 Electrostatic Discharge

TEST ITEM	CONDITIONS	Note
ESD	150pF , 330Ω , ±8kV&±15kV air& contact test	1
	200pF , 0Ω , ±200V contact test	2

Note: Measure

- 1: LCD glass and metal bezel
- 2: IF connector pins

7.4 Judgment Standard

The judgment of the above test should be made as follow:

Pass: Normal display image with no obvious non-uniformity and no line defect.

Partial transformation of the module parts should be ignored.

Fail: No display image, obvious non-uniformity, or line defects.

HAU DISPLAY Only Confidential