

S4565XM SERIES

IGNITION CONTROLS FOR COMBINED VALVE AND IGNITION MODULATING SYSTEM

PRODUCT HANDBOOK

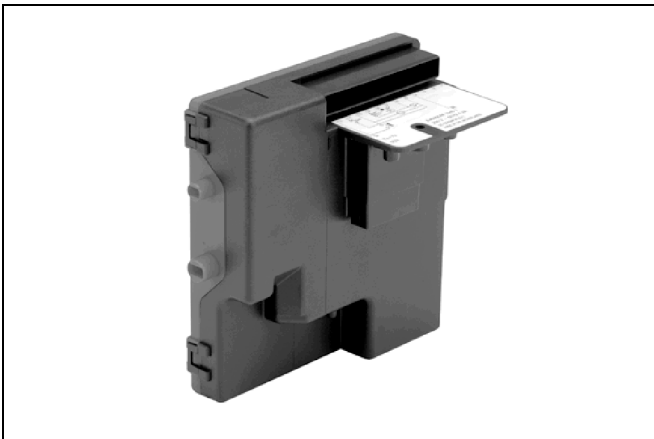

APPLICATION

The S4565xM ignition controls have been specially developed for application in gas fired domestic appliances.

The S4565xM ignition controls are used in conjunction with the VK4105G gas controls (Product Handbook EN2R-9025) to provide an optimised safety sub-system for programmed safe light-up and flame supervision of the main burner of the appliance.

S4565xM ignition controls are available for **Direct Burner Ignition (DBI)** systems with a defined safety ignition time.

For glossary of terms, abbreviations and symbols see document EN2R-9039

Contents

| General | Page |
|--|------|
| Description | 2 |
| Features | 2 |
| Technical | |
| Dimensional drawing S4565xM ignition control | 3 |
| Specifications | 4 |
| Connection diagram | 7 |
| System operation | 9 |
| Timing diagram | 10 |
| General considerations | 11 |
| Electrical connections and wiring | 12 |
| Adjustments and final checkout | 13 |
| Tolerances and product life | 14 |
| Various | |
| EMC guidelines | 14 |
| Quality assurance statement | 14 |
| Standards and approvals | 15 |
| Ordering information | 15 |
| Replacement parts and accessories | 16 |

DESCRIPTION

The **CVI-m** system comprises a modulating gas control with on/off or NTC operated control and modulating function or Hi-Lo function and an ignition control with integrated power supply for the electric modulating operator.

S4565xM ignition controls give excellent performance and a high reliability standard.

S4565xM ignition controls are applicable for **Direct Burner Ignition (DBI)**.

S4565xM ignition controls are applicable for heating appliances with or without fan, with flame detection, volatile or non volatile lock out, optional remote reset and fixed waiting times.

In case of flame failure recycle of the full start up sequence occurs.

The performance and the construction of the ignition control is easy to mount and optimized and dedicated to click on the VK4105G gas controls.

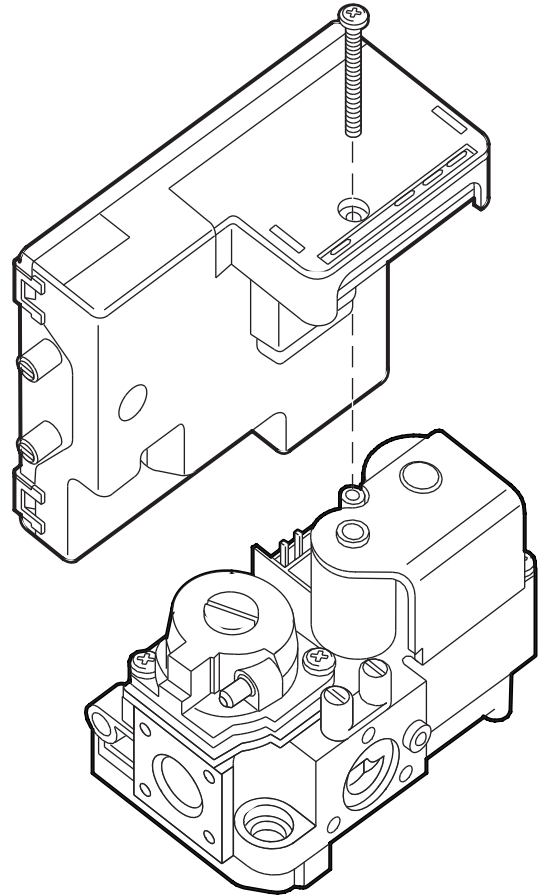

FEATURES

General

- All burner control safety functions concentrated in one reliable and optimized approved system.
- Specially designed to provide the optimum system solution in modulating gas appliances with a DBI to light the main burner.
- Easy assembly of ignition control on gas control by plugging it. This construction eliminates wiring mistakes.

Electrical connection

- The appropriate ignition control can be connected to the valve by plugging it on.
- Electric connections are positioned on top and are made by a multiple plug-in connector (IP 20 enclosure).
- Ignition and flame detection connections are at the outlet end of the housing.
- Ignition connection AMP 2.8 x 0.5 mm spade terminal.
- Flame detection connection AMP 4.8 x 0.8 mm spade terminal in case of dual rod.

Electrical connection options

- The housing can receive a cover with strain relief
- When applied in combination with the cable seal grommet the S4565xM ignition control has an IP 40 or optional IP 44 enclosure.

Ignition control

- Hybrid technology for high reliability.
- Flame supervision on ionisation principle.
- Built-in 5 ... 60 Hz ignition.
- Integral or external reset and alarm.
- Accurate safety timer.
- Full operating sequence after flame loss.
- Extended spark ignition.
- Volatile or non volatile lock-out according EN 298.
- Optional EMC filter
- Flame rod safe accessible by means of protective impedance.
- Optional permanent alarm indication.
- Optional flame retardant housing (UL 94-V0)
- Fast open or electric adjustable step open.
- Built in driver for gas modulation.
- Safe low voltage PWM input for modulation signal.
- Optional Hi-Lo input.
- Optional phase independent flame detection.
- Optional NTC sensor modulated control with internal or external potentiometer for temperature setting.

DIMENSIONAL DRAWING S4565XM IGNITION CONTROL

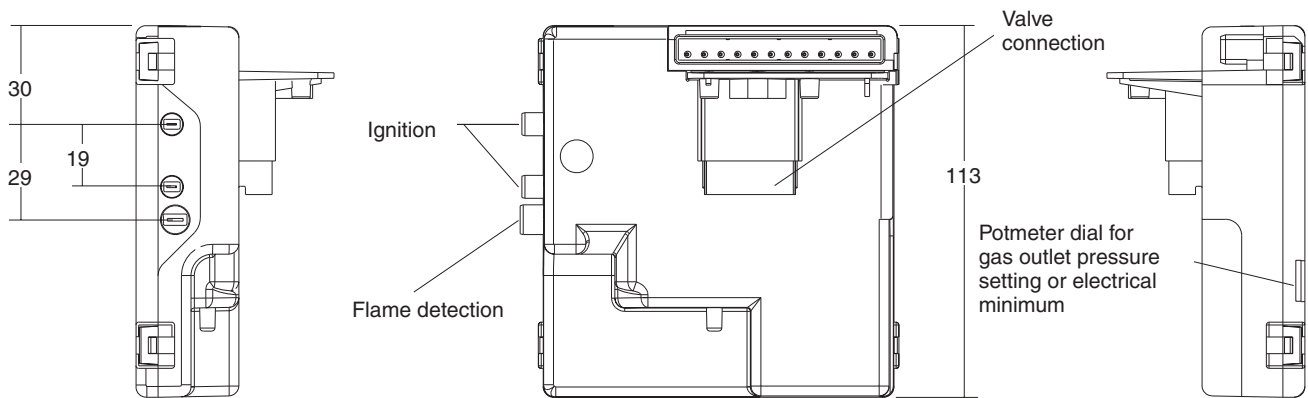
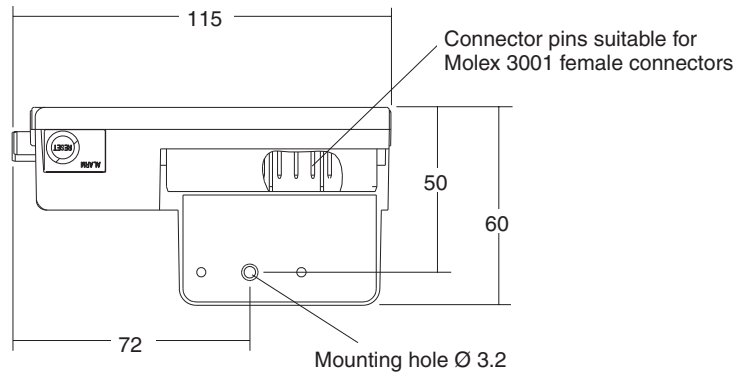

Note: specific housings may deviate from drawing

S4565AD ...TD

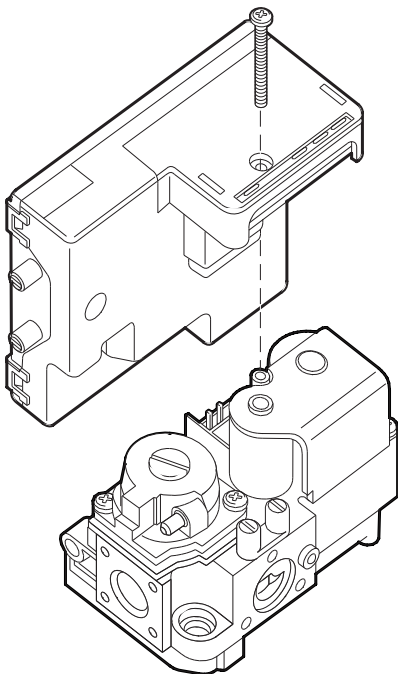

SPECIFICATIONS

Models

| Application | Non volatile | Volatile |
|--|--------------|----------|
| Atmospheric DBI, modulation input, Hi-Lo input or NTC input. | S4565AM | S4565PM |
| Atmospheric DBI with fixed or adjustable ignition pressure | S4565BM | S4565QM |
| Fan assisted | S4565CM | S4565RM |
| Fan assisted with fixed or adjustable ignition pressure | S4565DM | S4565TM |

For all models electrical minimum is adjustable with thumbwheel potmeter in the housing.

For suffix BM, DM, QM, and TM either ignition pressure or electrical minimum pressure (non fail safe) is adjustable with thumbwheel potmeter in the housing.

For models with NTC input the temperature set point is adjustable with the thumbwheel or the external potmeter or not adjustable, depending on O.S. number. If an external potmeter is connected than ignition pressure or electrical minimum is adjustable with integral thumbwheel potmeter.

Supply voltage

230 Vac, 50 Hz

Power consumption

4 VA

Humidity

90% RH max. at 40°C

Ambient temperature

-15 ... 60°C

Storage temperature

-20 ... 60°C

Electrical rating

Alarm: 230 Vac, neon lamp output max 1 mA.
 Fan: 230 Vac, 1 A max, $\cos \varphi > 0.6$
 Air proving switch: 230 Vac, 0.1 A max
 Limit thermostat: 230 Vac, 0.1 A max
 Control thermostat: 230 Vac, 1.5 A max, $\cos \varphi > 0.6$
 PWM input: 12V \pm 4V, 1 k Ω ,
 PWM frequency: 0.2 ... 0.5 kHz synchronized to even harmonics of 50 Hz mains; curve specified.
 PWM frequency: 0.1 and 0.6 ... 1 kHz synchronized to even harmonics of 50 Hz mains; curve **not** specified.
 PWM on/off ratio: 0 ... 100 %
 Hi-Lo switch: 230 Vac, 0.1A max.
 NTC sensor: T7335 series, if suitable for 1250 V dielectric strength, 1 M Ω at 25 °C

Thumbwheel potmeter can optionally be used as **either** ignition pressure adjustment, electrical minimum pressure adjustment or temperature set point adjustment.

Ignition pressure adjustment

Adjustment range: 2.5 ... 10 mbar.

Electrical minimum pressure adjustment

Adjustment range: 2.5 ... 10 mbar.

Temperature set-point adjustment

Adjustment range: 10 ... 90 °C

Electrical connection

High voltage spark: 2.8 mm spade terminal
 Flame sensing: 4.8 mm spade terminal
 PCB connectors: Molex 3003 series suitable for Molex 3001 female cable connector

Housing (degree of protection)

IP 20 (standard)

As accessory a strain relief (order number 45.900.440-001) is available.

IP 40

Use: cover set 45.900.431-004 or
 cover set 45.900.431-005
 (flame retardant according to UL94-VO)
 cable grommet 45.900.442-008

IP 44 (only applicable for specific O.S. numbers)

Use: cover set 45.900.431-004 or
 cover set 45.900.431-005
 (flame retardant according to UL94-VO)
 cable grommet 45.900.442-008
 sleeve 45.900.442-003
 gasket 45.900.442-011

Timing (depending on O.S. number)

Self check time (T_c): 1.5 ... 2.0 s
 Waiting time (T_w): 0 ... 10 s
 Safety time (T_s): 3 ... 25 s
 Ignition pressure step delay: 0 ... 2 s
 Extended spark ignition time: 0 ... T_s (dependent on elaps of safety time)

Flame sensing

Min flame current:
 for optional phase independent versions: 0.5 μ A
 for phase dependent versions: 0.9 μ A
 Response time on: > 0.2 s
 Response time off (T_{FR}) at $I_{flame} + 2 \mu$ A: < 1.0 s

Ignition

Spark voltage: 12 kV at 40 pF load
(depending on O.S. number)
Spark energy: 3 ... 15 μ As
Repetition rate: 5 ... 50 Hz (depending on
O.S. number)
Max. spark gap: 3.5 mm

Length flame sensing cable

1 m max.

Length ignition cable

0.5 m max.

Length of wiring for external components

1 m max.

P control (for O.S. numbers with NTC input only)

Proportional band: 1 ... 10 °C.

Remark

PWM input (dependent on O.S. number) has safe separation with respect to mains voltage.

NTC and Hi-Lo input (dependent on O.S. number) have **no** safe separation with respect to mains voltage.

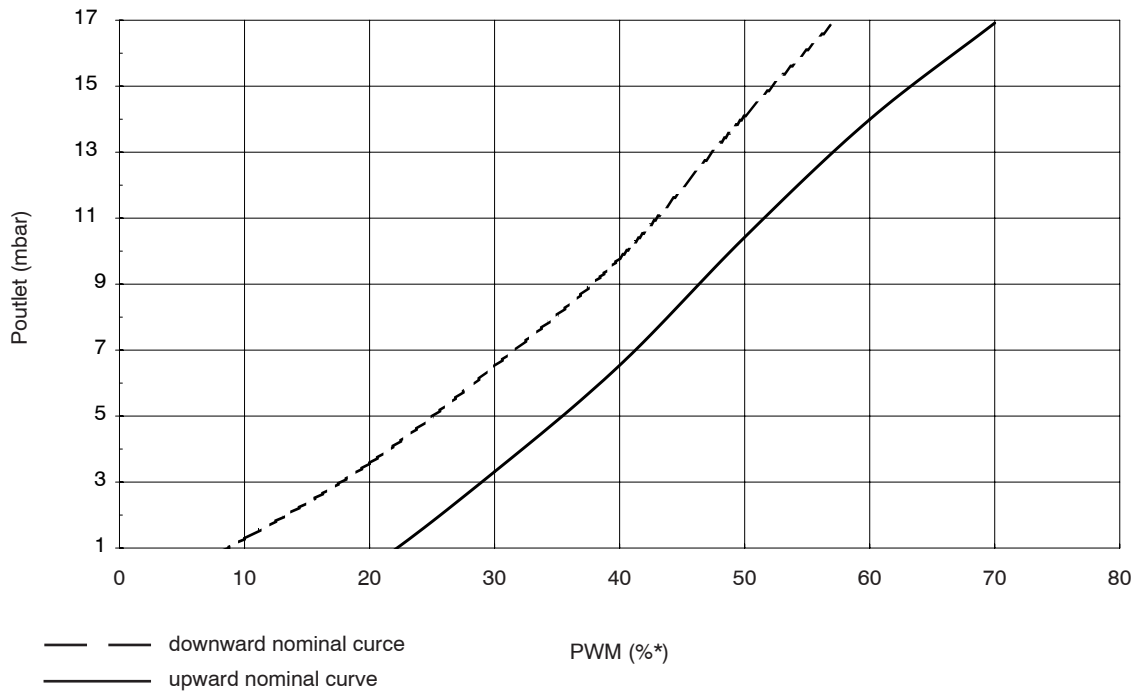

* HI-Lo versions:

Hi-Lo contact open corresponds to 0% PWM

Hi-Lo contact closed corresponds to 100% PWM

Fig. 1. Nominal graph modulating performance at 20 mbar inlet pressure, \varnothing 4.3 mm outlet restriction

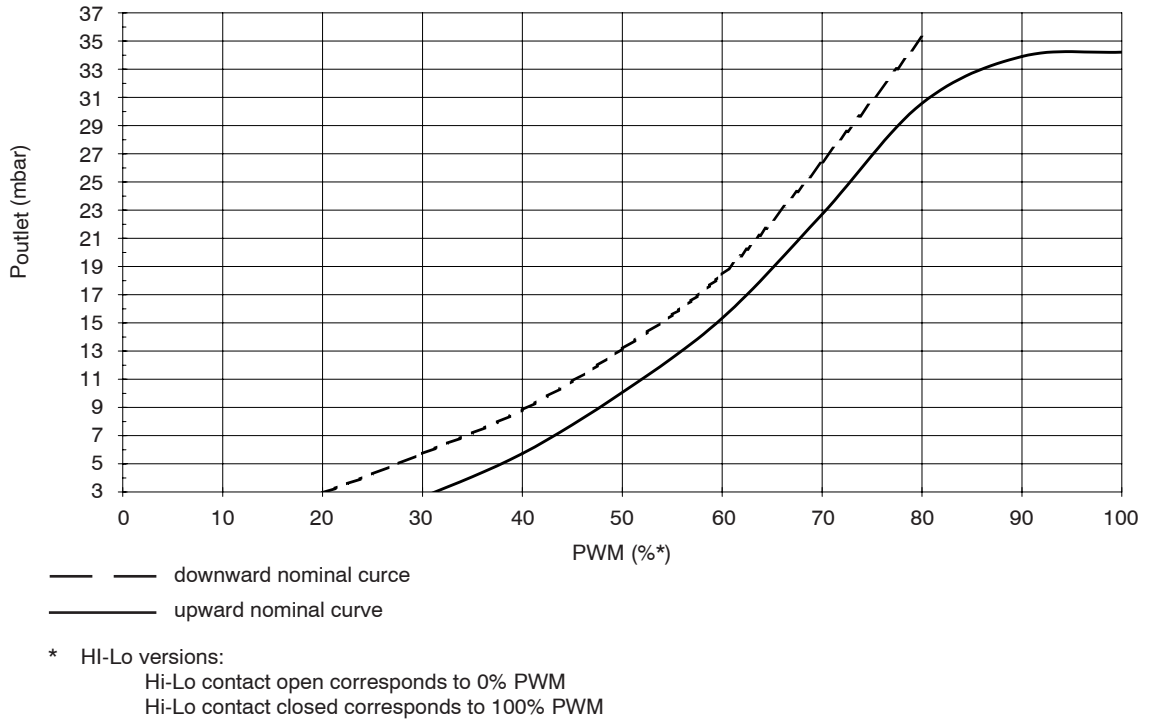

Fig. 2. Nominal graph modulating performance at 37 mbar inlet pressure, Ø 2.8 mm outlet restriction

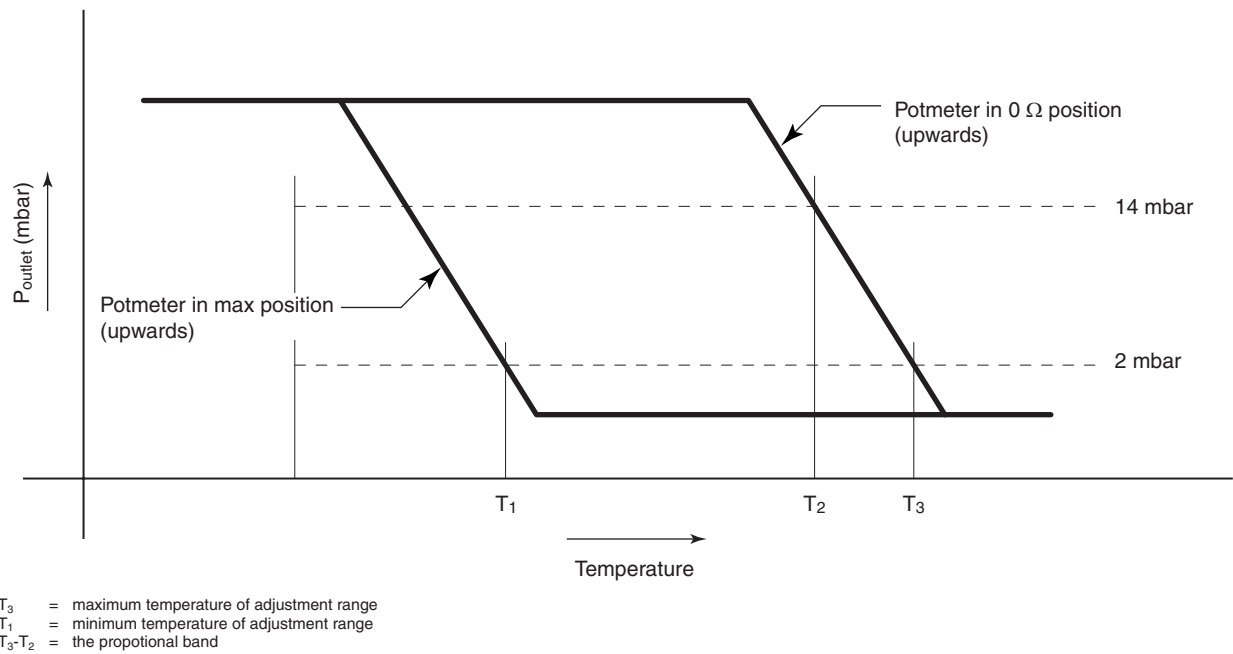
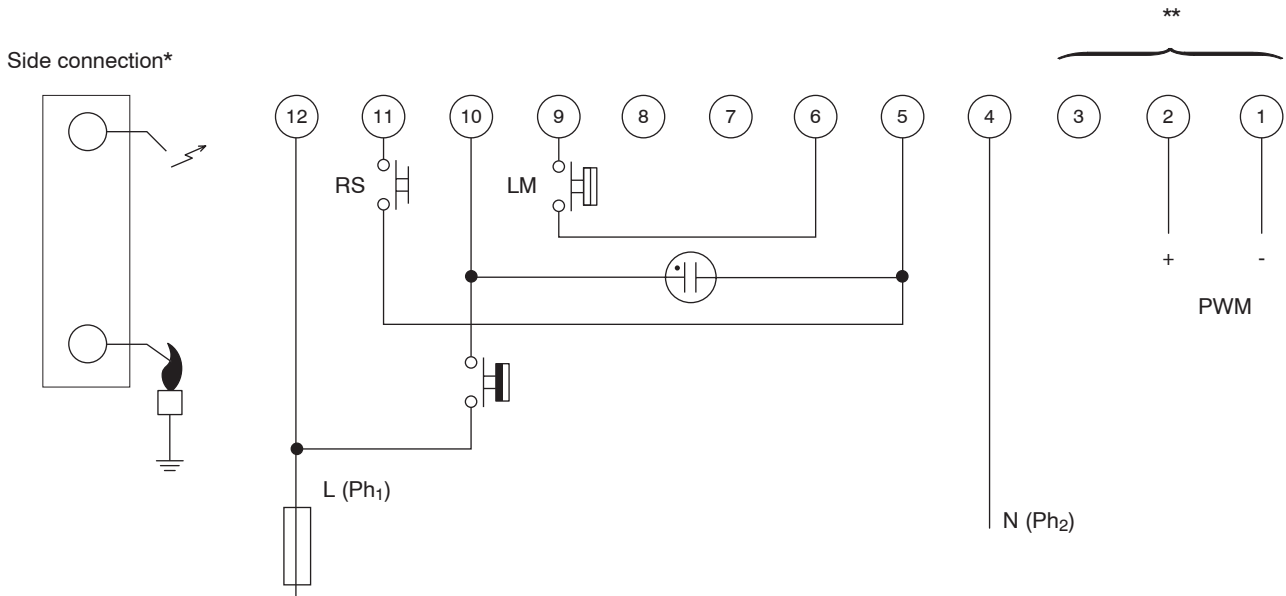

Fig. 3. Nominal graph modulating performance in case of CVI-m with NTC and proportional control

CONNECTION DIAGRAM



* See see fig. 10. and fig. 11. on page 8 for alternative side connection

** For S4565AM, CM, PM, RM with Hi-Lo see fig. 6. on page 8.

For S4565BM, DM, QM, TM with Hi-Lo see fig. 7. on page 8.

For S4565AM, BM CM, PM, QM, RM, TM with NTC sensor see see fig. 8. and see fig. 9. on page 8

Fig. 4. Connection diagram S4565AM, BM, PM, QM

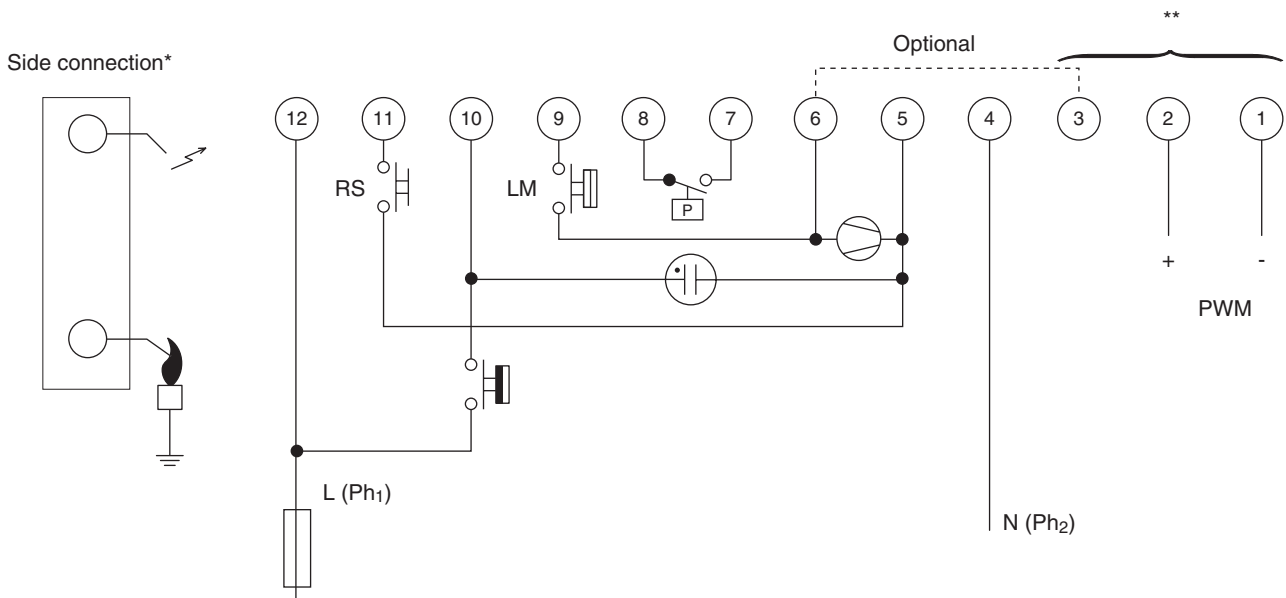

* See see fig. 10. and fig. 11. on page 8 for alternative side connection

** For S4565AM, CM, PM, RM with Hi-Lo see fig. 6. on page 8.

For S4565BM, DM, QM, TM with Hi-Lo see fig. 7. on page 8.

For S4565AM, BM CM, PM, QM, RM, TM with NTC sensor see see fig. 8. and see fig. 9. on page 8

Fig. 5. Connection diagram S4565CM, DM, RM, TM

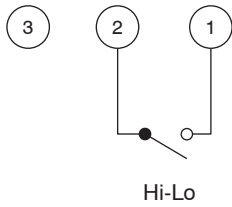

Fig. 6. Connection S4565AM, CM, PM, RM with Hi-Lo

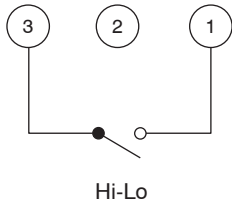

Fig. 7. Connection S4565BM,DM, QM, TM with Hi-Lo

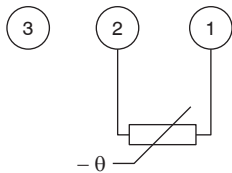

Fig. 8. Connection S4565AM, BM, CM, DM, PM, QM, RM, TM with NTC sensor

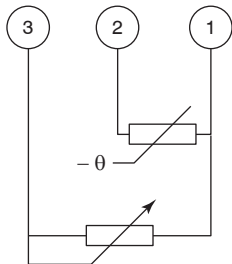

Fig. 9. Connection S4565AM, BM, CM, DM, PM, QM, RM, TM with NTC sensor and external potentiometer for temperature setpoint

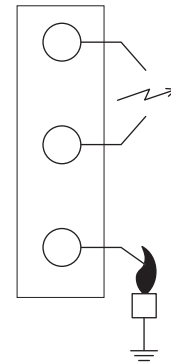

Fig. 10. Side connection for closed loop sparking

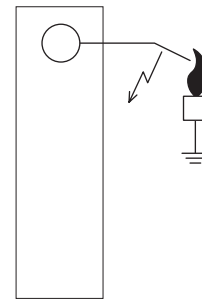

Fig. 11. Side connection for combined ignition and flame sensing

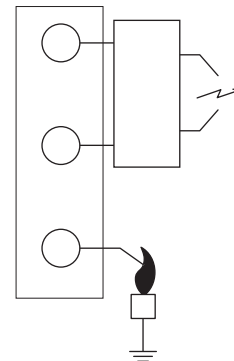

Fig. 12. Side connection for external igniter

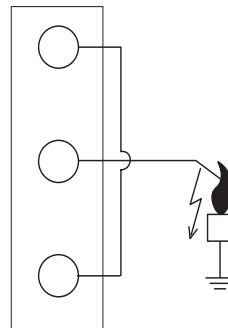

Fig. 13. Alternative side connection in case of combined flame sensing and sparking

SYSTEM OPERATION

General

The S4565xM ignition controls can provide both closed-loop sparking and sparking to ground.

If the closed loop sparking S4565xM will be used in sparking to ground applications, the upper spark electrode has to be grounded.

The output pressure of the gas valve can be controlled with the PWM input signal, Hi-Lo switch or NTC sensor.

Before each start of the boiler, the S4565xM does an internal safety check. The time needed to do this check is called self check time T_c .

Suffix AM and PM (see fig. 14.)

When there is a call for heat a self check periode (T_c) plus waiting period (T_w) elapses before built-in igniter and gas valve are switched on.

The ignition spark ignites gas and resulting flame is detected by the flame rod.

Ignition is switched off after a predetermined extended ignition time and flame establishment.

If flame is not established within the safety time (T_s), the ignition control locks out.

If the flame is lost during normal run, the ignition control repeats start sequence.

Suffix BM and QM (see fig. 14.)

As AM and PM except a fixed or with potmeter adjustable start pressure occurs during the no flame detection period.

The no flame detection period can be extended. This is called: "Ignition pressure step delay".

Suffix CM and RM (see fig. 15.)

When there is a call for heat the self check period (T_c) plus waiting period (T_w) elapse if the air flow proving switch (APS) is in the no air position.

After $T_c + T_w$ the fan starts running.

When sufficient air flow is proven by the air proving switch, the built-in igniter and gas valve are switched on.

The ignition spark ignites gas and resulting flame is detected by the flame rod.

Ignition is switched off after a predetermined extended ignition time and flame establishment.

If flame is not established within the safety time (T_s), the ignition control locks out.

If the flame is lost during normal run, the ignition control repeats start sequence.

If air flow is lost during operation, a restart occurs.

If no air is proven by the air flow proving switch (APS), the ignition control stays waiting (optional lock out on no air can be included).

Suffix DM and TM (see fig. 15.)

As CM and RM except a fixed or with potmeter adjustable start pressure occurs during the no flame detection period.

The no flame detection period can be extended. This is called: "Ignition pressure step delay".

Lock-out reset

The ignition control can be is reset by either depressing the internal/external reset button (suffix AM, BM, CM and DM) or by interrupting the permanent life (suffix PM, QM, RM, and TM).

TIMING DIAGRAM

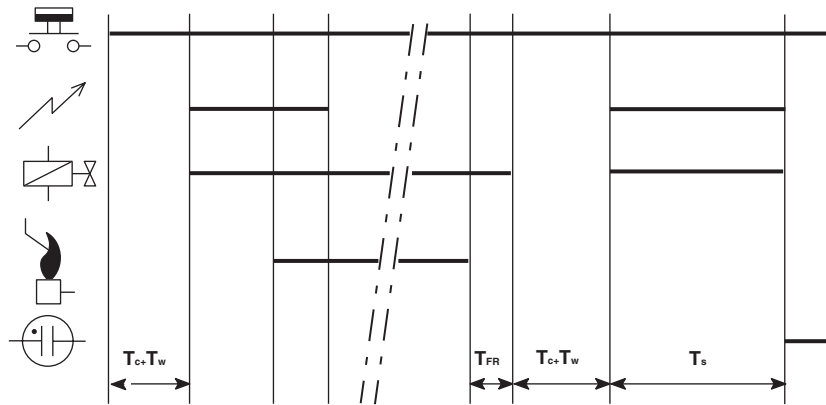

Fig. 14. Functional diagram S4565AM, BM, PM, QM

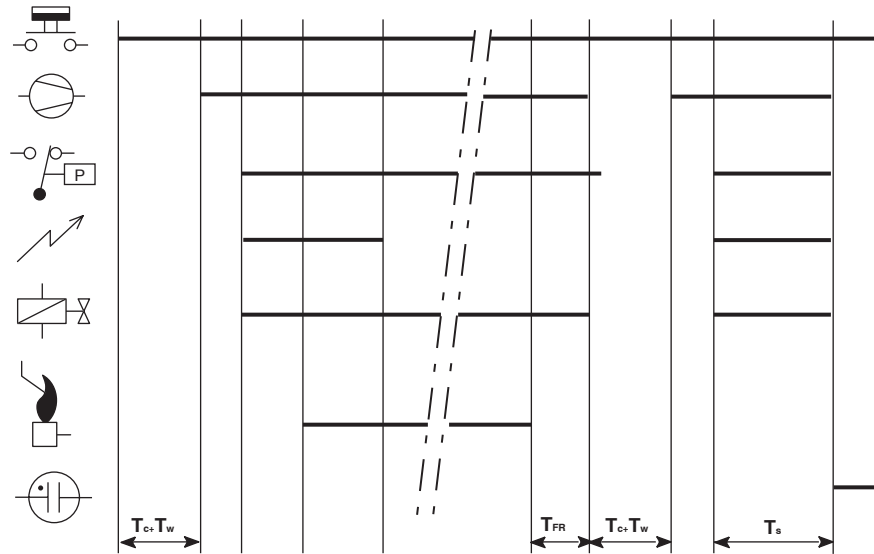

Fig. 15. Functional diagram S4565CM, DM, RM, TM

GENERAL CONSIDERATIONS

To ensure reliable long term operation, mount the ignition control at a position in the appliance with a low ambient temperature and a low radiation.

The ignition control should be externally fused.

High temperatures will affect product life.

NOTE 1.:If during normal use the reset button is pressed, the gas valves drop out and the ignition control starts a new sequence after releasing the reset button.

NOTE 2.:Electrical rating of connected controls and air proving switch should be appropriate for the load that is switched by the ignition control.

NOTE 3.:Power interruptions will cause program restart.

NOTE 4.:If the S4565xM ignition control incorporates an EMC filter, disconnect the ignition control from mains before performing a dielectric strength test.

NOTE 5.:When first starting, the control can be in the lock-out condition; reset the ignition control.

If a first reset is not succesful, wait at least 15 seconds before attempting another one.

After a reset an extended waiting time will occur.

NOTE 6.:The flame connection pin of all types is protected against electrical shock.

NOTE 7.:If an automatic return high limit thermostat is used, the high limit switch in the application needs a longer return time than the trial for ignition time of the control. This in order to provide non volatile lock out.

NOTE 8.:The modulation function, Hi-Lo function or NTC operation of the S4565xM ignition control units are not checked during the start up safety check. As a result the gas technical safety of the appliance provided with a S4565xM ignition control unit should not rely on the proper functioning of the adjustable gas outlet pressure during ignition and modulation function, Hi-Lo function or NTC operation of this ignition control unit.

NOTE 9.:If permanent alarm output:neon indicator with integral resistor >150 k Ω (max 1 mA).
Do not connect any electrical load to the heat demand input, it will influence proper functionality.

NOTE 10.:If the modulation function is "high", the burner pressure is and stays high after succesfull start.
The control does not modulate



WARNING

Honeywell is not responsible for damage and/or injury due to mis wiring.

After installation ignition control can become wet due to condensation. **Do not connect wet device to mains.**

ELECTRICAL CONNECTIONS AND WIRING

WARNING

Take care that installer is a trained experienced service man.

Disconnect power supply to prevent electrical shock and/or equipment damage.

IMPORTANT

Wiring must be in accordance with local regulations.

The appliance manufacturer's instructions should always be followed when provided. If such instructions are not provided see the connection diagrams for typical systems.

Before installing or replacing any control check that type number is correct for the application.

Ensure combustion chamber is free of gas before start up.

Conduct a thorough check out when installation is completed.

At the first start the ignition control can be in lock out; depress reset button to free control.

CAUTION

Do not connect the ignition control to power supply when it is not connected to the gas control.

CAUTION

If ignition frequency ≤ 25 Hz the ignition cable and its connections shall be protected against electrical shock.

CAUTION

NTC sensor and external potmeter are not accessible. Proper isolation must be supplied.

Wiring

- Use leadwire which can withstand at least 105°C ambient.
- Use leadwire which is proven against moisture.
- Wiring between ignition control and spark sensing probe should have good quality insulation, suitable for the temperatures encountered.

Fusing

In order to prevent unsafe conditions at too high current, the ignition control has two integral non replaceable fuses. This fuse will be blown long before the maximum 16 A external fuse switches off.

Spark gap

Max. allowable spark gap 3.5 mm

Supply voltage polarity for phase dependent versions

WARNING

If ignition control seems to operate normally but does not detect flame, check for right polarity of power supply (line, neutral).

If there is no sufficient flame current due to phase-phase mains it is recommendable to use a phase independent version.

Assembling of the cable connector(s) and cover (see fig. 16.)

- Use cable with $\varnothing 5 \dots \varnothing 7$ mm.
- Strip length cable: 15 mm
- Grommet inlet numbers 1, 2, 4 applicable for cable with $\varnothing 5 \dots \varnothing 7$ mm.
- Grommet inlet number 3 applicable for cable with $\varnothing 4 \dots \varnothing 7$ mm.
- Mount the connector(s) and bring the cable grommet in position over the cables and connector.

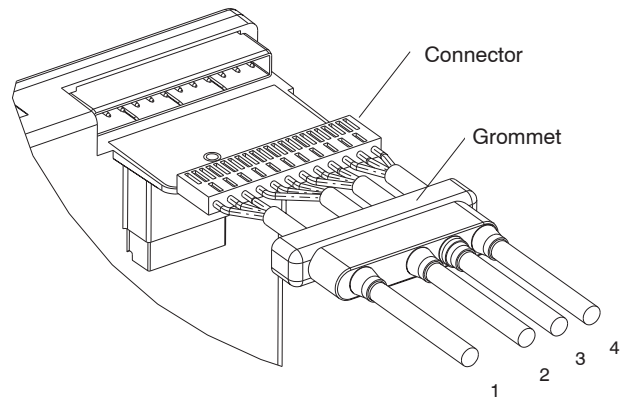

Fig. 16.

Assembly of strain relief (see fig. 17.)

Position the cover on the ignition control. Then, when holding the cover down (in direction A) rotate it to mount the cable(s) in the strain relief (in direction B).

Finally fix the whole assembly (ignition control and cover) with a screw on the gas control with a torque of 40 Ncm max.

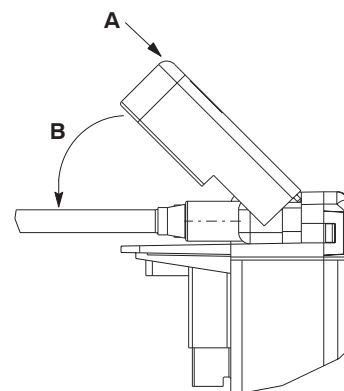

Fig. 17.

ADJUSTMENTS AND FINAL CHECKOUT

WARNING

Adjustments must be made by qualified persons only. If the appliance manufacturer supplies checkout and/or service and maintenance instructions carefully follow them. If these instructions are not provided then use the procedure outlined below.

IMPORTANT

Depending on O.S. number either an adjustment of gas outlet pressure during ignition or an electrical minimum gas outlet pressure adjustment is available.

Setting of electrical minimum rate (if applicable)

- Disconnect PWM input signal.
- Set thumb wheel potmeter to minimum.
- Make sure appliance is running.
- Check gas input to the appliance using a clocking gas meter or alternatively a pressure gauge connected to the outlet pressure tap.
- Turn mechanical minimum adjustment screw counter-clockwise to increase the minimum gas flow to the desired value. See dimensional drawing in Product Handbook EN2R-9025.
- If minimum gas pressure cannot be reached with mechanical minimum, increase minimum gas pressure with thumb wheel potmeter to desired value.
- Connect PWM input signal.

Adjustment of gas outlet pressure during ignition (if applicable)

- Disconnect flame detection or connect it to earth.
- Start up boiler.
- Set the gas outlet pressure during the safety time with the thumb wheel potmeter.
- Reset the appliance if necessary and check/readjust until the desired gas outlet pressure is set.
- Allow 15 seconds recovery time between two start attempts.
- Check if gas outlet pressure is correct.
- Connect the flame detection.

NOTE: For the best accuracy keep following sequence:

- ① Make minimum rate setting.
- ② Set the gas outlet pressure during ignition.

Checking flame current

- For phase **dependant** versions the minimum value should be 0.9 μ A.
- For phase **independant** versions the minimum value should be 0.5 μ A.
- To check flame current connect a DC micro-Ampèremeter between flame sensing wire and flame sensing rod.
- Meter connections polluted with e.g. alkaline substances lying close to earth can cause flame current simulation. Make sure no false flame current can flow from meter connections to earth.
- If flame current is insufficient check that the flame sensing rod is fully enveloped by the flame and that the burner and the ignition control are reliable grounded.

Final checkout

After installation and any adjustment start the appliance and observe a complete cycle to ensure that all burner components function correctly.

Maintenance and service

Under normal circumstances no maintenance or service is required.

TOLERANCES AND PRODUCT LIFE

Line voltage

230 V, - 15% + 10%

Line voltage frequency

50 Hz ± 2 Hz

Under voltage disabling limit

173 Vac ± 10 Vac

Safety time (T_s)

$0.8 \times T_{spec} \leq T \leq T_{spec}$

Self check time (T_c)/Waiting time (T_w) at 230 V mains

$0.5 T_{spec} \leq T \leq 1.5 T_{spec}$

Spark frequency at 230 V line voltage

$0.7 f_{spark} \leq f_{spark} \leq 1.4 f_{spark}$

Spark energy

$u0.6 < \text{specified spark energy}$

No flame current

For phase **independant**: no flame < 0.24 μ A

For phase **dependant**: no flame < 0.45 μ A

Product life

500.000 cycles for safety and main valve operator of gas valve

250.000 cycles at rated loads

6.000 lock out operations with rated loads

EMC GUIDELINES

The ignition cable has to be determined for lowest emission. Do not lead ignition cable close to other cabling. To suppress Radio Frequency Interference (RFI) the ignition control including spark igniter cabling should be mounted in sufficient shielded environment.

QUALITY ASSURANCE STATEMENT

Products are manufactured under an ISO 9001 (1994) based and certified Quality System.

The quality system is described in the Honeywell Combustion Controls Center Quality Assurance Programme and its related operational procedures and instructions.

The quality system is approved by Gastec against certificate number 9.302/2.

The quality organisation is responsible for defining, maintaining, improving and verification of the quality systems in the field of design, production process and field quality service.

Assembly processes are guided by work instructions. Patrol inspections form part of the assembly processes.

Assembly inspection is performed by employees of the quality control department, using their own authorised equipment.

All inspections (incoming and assembly) are performed by trained personel and according inspection procedures.

STANDARDS AND APPROVALS

Standards

The S4565xM has been designed to meet the European Standards:

- EN 298: Automatic gas burner control systems.
- EN 60730-1: Automatic electric controls for household and similar use.

Regarding electric safety, the S4565xM can be used in appliances according to European Standard for household electrical requirements EN 60335 series

S4565xM systems function in accordance with EN 298.

| | |
|------------------|------------------|
| S4565AM, BM..... | code A/M/C/L/X/N |
| S4565CM..... | code F/M/C/L/X/N |
| S4565DM..... | code F/T/C/L/X/N |
| S4565PM, QM..... | code A/M/C/V/X/N |
| S4565RM, TM..... | code F/M/C/V/X/N |

Approvals

The ignition control conforms with the following EC - Directives:

- Gas Appliance Directive (90/396/EEC)
 - Low Voltage Directive (73/23/EEC)
 - Electro Magnetic Compatability Directive (89/336/EEC)*
- * Conformity with Electro Magnetic Compatibility Directive regarding emission for non industrial appliances can be assumed for selected Ordering .Specification (O.S.) numbers only. However conformity can only be declared as part of the appliance.

For other O.S. numbers, additional suppression means may be needed within the appliance.

Details per O.S. number can be found in the Approvals List.

Regarding immunity, all controls comply with the levels for non industrial appliances.

ORDERING INFORMATION

When ordering specify:

- Model number of CVI ignition components required: see model number chart below.
- The correct pilot burner for the installation concerned: refer to Honeywell ignition products guide EN0R-0038.
- Order numbers of replacement parts and accessories required.

NOTE: Ignition controls, replacement parts and accessories will be available under "TRADELINE" label. Ask your wholesaler for details.

NOTE: An up-to-date product survey, with details of all new and existing products in these series, is available. Contact your local Honeywell sales representative for more information.

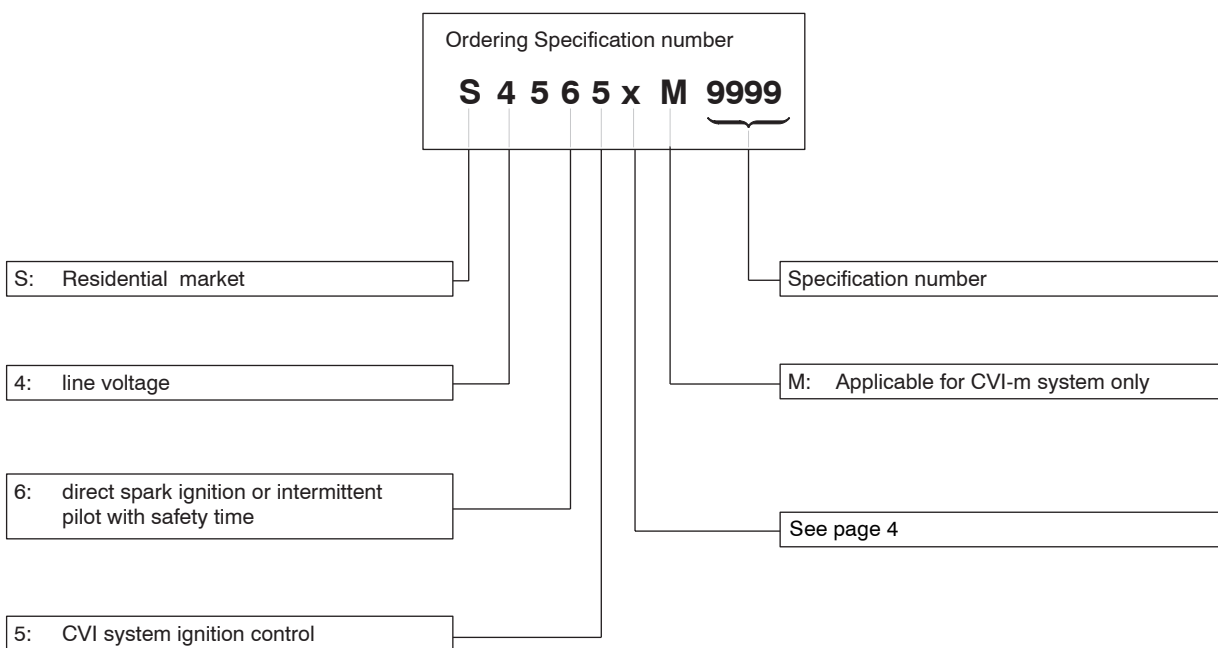

Fig. 18. Model number chart S4565xM

REPLACEMENT PARTS AND ACCESSORIES

Covers and plugs

| Description | Packing quantity | Ordernumber |
|--|------------------|----------------|
| Cover with screw | 192 | 45.900.431-004 |
| Cover with screw (flame retardant according to UL94-VO) | 192 | 45.900.431-005 |
| Cover without screw (flame retardant according to UL94-VO) | 192 | 45.900.431-006 |
| Strain relief | 192 | 45.900.440-001 |
| Grommet up to 4 cables | 192 | 45.900.442-008 |
| Grommet up to 4 cables | 960 | 45.900.442-009 |
| Grommet with wire feed | 100 | 45.900.442-010 |
| Sleeve for sealing spark electrode and flame detector | 192 | 45.900.442-003 |

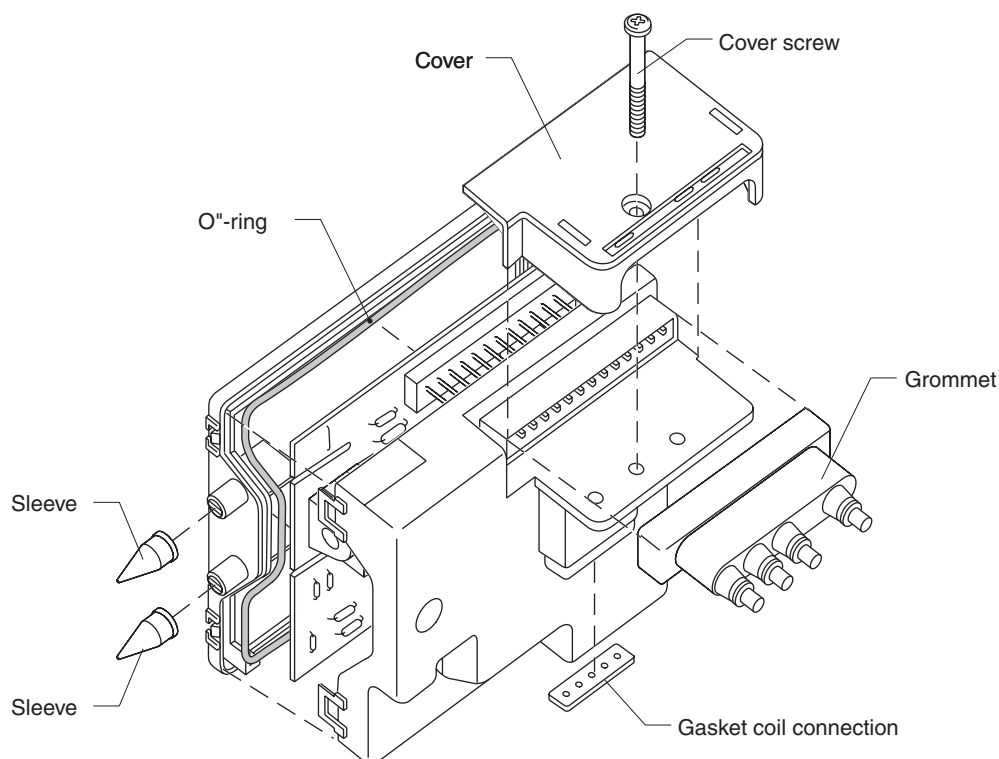

Fig. 19. S4565xM exploded view IP 44 enclosure

Honeywell

Home and Building Control
 Combustion Control Center Europe
 Honeywell BV
 Phileas Foggstraat 7
 7821 AJ Emmen
 The Netherlands
 Tel.: +31 (-)591 695911
 Fax: +31 (-) 591 695200
<http://europe.hbc.honeywell.com>