Automatic Mode Shift 2ch 150mA LDO

NO.EA-138-070806

OUTLINE

The R5326x Series are CMOS-based voltage regulator ICs with high output voltage accuracy, Typ. 5.5 μ A low supply current, and remarkably improved transient response compared with the conventional low supply current voltage regulators. The supply current of IC itself is automatically shifts between fast mode and low power mode depending on the load current. (The current threshold is fixed internally.) Each of these voltage regulator ICs consists of a voltage reference unit, an error amplifier, resistors for setting the output voltage, a current limit circuit for preventing from the destruction by an over current, and so on.

The chip enable function realizes the standby mode with ultra low supply current.

Since the packages for these ICs are SOT-23-6 and PLP1820-6, and chip size package, WLCSP-6-P1, 2ch LDO regulators are included in each package, high density mounting of the ICs on boards is possible.

FEATURES

- Supply Current (Low Power Mode).....Typ. 5.5 μ A \times 2 (VR1&VR2) ($I_{OUT}=0$ mA)
- Supply Current (Fast Mode).....Typ. 50 μ A \times 2 (VR1&VR2) ($I_{OUT}=10$ mA)
- Standby CurrentTyp. 0.1 μ A (VR1&VR2)
- Input Voltage 1.4V to 6.0V
- Output Voltage 0.8V to 4.2V
- Dropout VoltageTyp. 0.19V ($I_{OUT}=150$ mA, $V_{OUT}=2.8$ V)
- Output Voltage Accuracy..... $\pm 1.0\%$ ($V_{OUT} \geq 1.5$ V)
- Ripple Rejection.....Typ. 70dB ($f=1$ kHz)
Typ. 60dB ($f=10$ kHz)
- Line RegulationTyp. 0.02%/V
- PackagesWLCSP-6-P1, PLP1820-6, SOT-23-6
- Built-in fold-back protection circuitTyp. 50mA (Current at short mode)
- Ceramic Capacitor is recommended. 1.0 μ F to 3.3 μ F
(Depending on V_{IN} and set V_{OUT} . Refer to the electrical characteristics table.)

APPLICATIONS

- Power source for handheld communication equipment.
- Power source for electrical appliances such as cameras, VCRs and camcorders.
- Power source for battery-powered equipment.

BLOCK DIAGRAMS

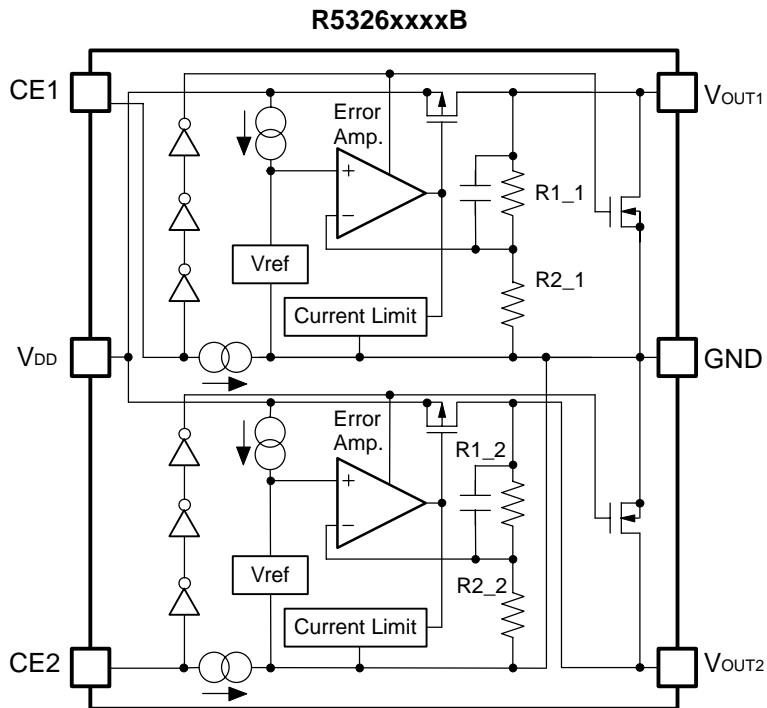
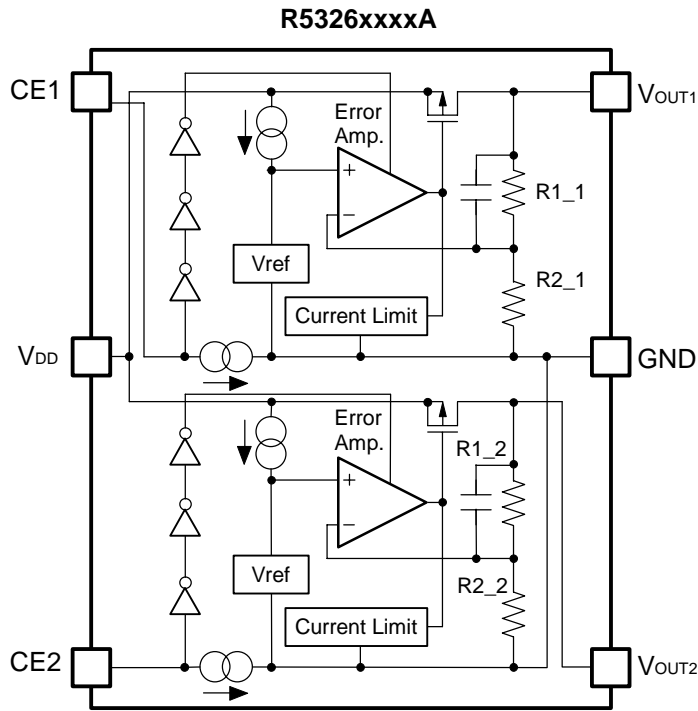

SELECTION GUIDE

The output voltage, auto discharge function*, and the taping type for the ICs can be selected at the user's request. The selection can be made with designating the part number as shown below;

R5326xxxxx-xx-x ←Part Number
 ↑ ↑ ↑ ↑ ↑
 a b c d e

Code	Contents
a	Designation of Package Type: N: SOT-23-6 K: PLP1820-6 Z: WLCSP-6-P1
b	Setting combination of 2ch Output Voltage (V_{OUT}): Serial Number for Voltage Setting, Stepwise setting with a step of 0.1V in the range of 0.8V to 4.2V is possible for each channel.
c	Designation of Mask Option: A: without auto discharge function* at OFF state. B: with auto discharge function* at OFF state.
d	Designation of Taping Type: Ex. TR (refer to Taping Specifications; for SOT-23-6 and PLP1820-6), E2 (for WLCSP-6-P1)
e	Designation of composition of plating: -F : Lead free plating (SOT-23-6, WLCSP-6-P1) None : Au plating (PLP1820-6)

*) When the mode is into standby with CE signal, auto discharge transistor turns on, and it makes the turn-off speed faster than normal type.

PIN CONFIGURATIONS

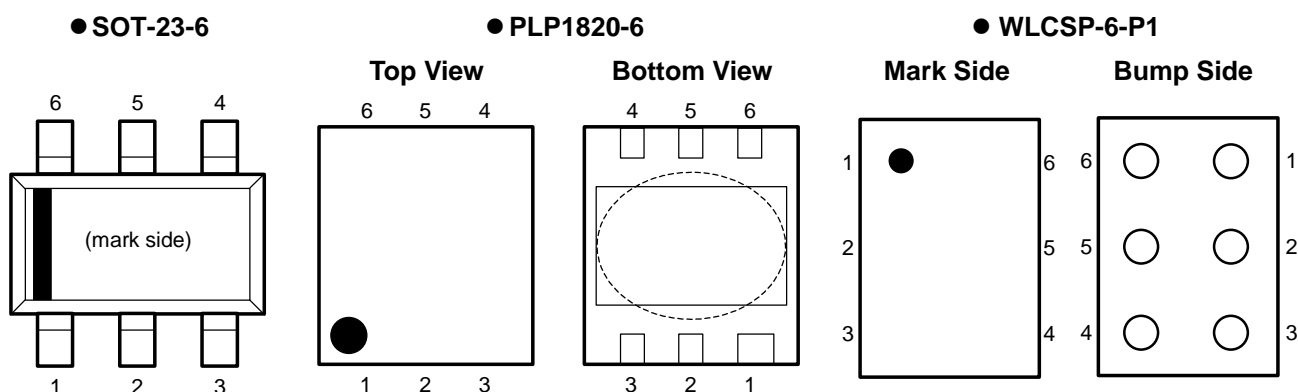

PIN DESCRIPTIONS

• SOT-23-6, WLCSP-6-P1

Pin No.	Symbol	Description
1	V_{OUT1}	Output Pin 1
2	V_{DD}	Input Pin
3	V_{OUT2}	Output Pin 2
4	CE2	Chip Enable Pin 2
5	GND	Ground Pin
6	CE1	Chip Enable Pin 1

• PLP1820-6

Pin No.	Symbol	Description
1	V_{OUT2}	Output Pin 2
2	V_{DD}	Input Pin
3	V_{OUT1}	Output Pin 1
4	CE1	Chip Enable Pin 1
5	GND	Ground Pin
6	CE2	Chip Enable Pin 2

* Tab in the  parts have GND level.
(They are connected to the back side of this IC.)
Do not connect to other wires or land patterns.

ABSOLUTE MAXIMUM RATINGS

Symbol	Item	Rating	Unit
V_{IN}	Input Voltage	6.5	V
V_{CE}	Input Voltage (CE Pin)	-0.3 to 6.5	V
V_{OUT}	Output Voltage	-0.3 to $V_{IN}+0.3$	V
I_{OUT1}, I_{OUT2}	Output Current	200	mA
P_D	Power Dissipation (SOT-23-6) *1	420	mW
	Power Dissipation (PLP1820-6) *1	880	
	Power Dissipation (WLCSP-6-P1) *1	633	
T_{opt}	Operating Temperature Range	-40 to 85	°C
T_{stg}	Storage Temperature Range	-55 to 125	°C

*1) For Power Dissipation, please refer to PACKAGE INFORMATION to be described.

ELECTRICAL CHARACTERISTICS

• R5326xxxxA/B

VR1/VR2

T_{opt}=25°C

Symbol	Item	Conditions	MIN.	TYP.	MAX.	Unit	
V _{OUT}	Output Voltage	V _{IN} -V _{OUT} =1V I _{OUT} =1mA	V _{OUT} > 1.5V	×0.99		×1.01	V
			V _{OUT} ≤ 1.5V	-15		+15	mV
I _{OUT}	Output Current	V _{IN} -V _{OUT} =1V	150			mA	
ΔV _{OUT} /ΔI _{OUT}	Load Regulation	V _{IN} -V _{OUT} =1V 1mA ≤ I _{OUT} ≤ 150mA			80	mV	
V _{DIF}	Dropout Voltage	I _{OUT} =150mA	0.8V ≤ V _{OUT} <0.9V		0.62	0.87	V
			0.9V ≤ V _{OUT} <1.0V		0.58	0.78	
			1.0V ≤ V _{OUT} <1.2V		0.48	0.69	
			1.2V ≤ V _{OUT} <1.5V		0.40	0.59	
			1.5V ≤ V _{OUT} <2.0V		0.31	0.48	
			2.0V ≤ V _{OUT} <2.8V		0.22	0.37	
			2.8 ≤ V _{OUT}		0.19	0.27	
I _{SS1}	Supply Current (Low Power Mode)	V _{IN} -V _{OUT} =1V, I _{OUT} =0mA		5.5	16	μA	
I _{SS2}	Supply Current (Fast Mode)	V _{IN} -V _{OUT} =1V, I _{OUT} =10mA		50		μA	
I _{standby}	Standby Current	V _{IN} -V _{OUT} =1V, V _{CE1} =V _{CE2} =GND		0.1	1.0	μA	
I _{OUTL}	Low Power Mode Current threshold	V _{IN} -V _{OUT} =1V, I _{OUT} =30mA to 1μA		0.6		mA	
I _{OUTH}	Fast Response Mode Current threshold	V _{IN} -V _{OUT} =1V, I _{OUT} =1μA to 30mA		3		mA	
ΔV _{OUT} /ΔV _{IN}	Line Regulation	V _{OUT} +0.5V ≤ V _{IN} ≤ 6V I _{OUT} =30mA (*V _{IN} ≥ 1.8V)		±0.02	±0.2	%/V	
RR	Ripple Rejection	Ripple 0.2Vp-p, V _{IN} -V _{OUT} =1V, I _{OUT} =30mA (In case that V _{OUT} <1.5V, V _{IN} -V _{OUT} =1.5V)	f=1kHz		70		dB
			f=10kHz		60		
V _{IN}	Input Voltage		1.4		6.0	V	
ΔV _{OUT} /ΔT _{opt}	Output Voltage Temperature Coefficient	I _{OUT} =30mA, -40°C ≤ T _{opt} ≤ 85°C		±100		ppm/°C	
I _{lim}	Short Current Limit	V _{OUT} =0V		50		mA	
I _{PD}	CE Pull-down Current		0.15	0.30	0.45	μA	
V _{CEH}	CE Input Voltage "H"		1.0		6.0	V	
V _{CEL}	CE Input Voltage "L"		0		0.4	V	
en	Output Noise	BW=10Hz to 100kHz		30		μV _{rms}	
R _{LOW}	Low Output Nch Tr. ON Resistance (of B version)			40		Ω	

TYPICAL APPLICATION

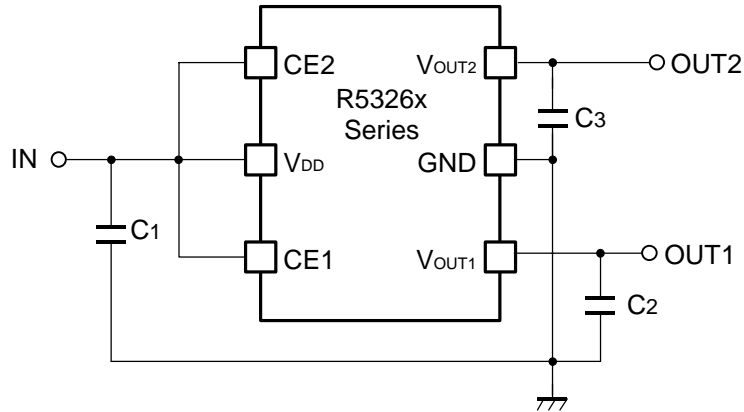

(External Components)
 Capacitor; Ceramic Type
 C1: 1 μ F Ceramic
 C2, C3: Refer to the following table

1. Mounting on PCB

Make V_{DD} and GND lines sufficient. If their impedance is high, noise pickup or unstable operation may result. Connect a capacitor with a capacitance value as much as 1.0 μ F or more as C1 between V_{DD} and GND pin, and as close as possible to the pins.

Set external components, especially the output capacitor, as close as possible to the ICs, and make wiring as short as possible.

2. Phase Compensation

In these ICs, phase compensation is made for securing stable operation even if the load current is varied. For this purpose, use capacitors C2 and C3 which are shown below table "Recommended Ceramic capacitor for output". If you use a tantalum type capacitor and ESR value of the capacitor is large, output might be unstable. Evaluate your circuit with considering frequency characteristics.

3. Recommended Ceramic capacitor for Output (C2, C3)

Output Voltage Range	Minimum Input Voltage	
	$1.4V \leq V_{IN} < 1.65$	$1.65 \leq V_{IN}$
$0.8V \leq V_{OUT} < 1.2V$	3.3 μ F or more	2.2 μ F or more
$1.2V \leq V_{OUT} \leq 4.2V$	3.3 μ F or more	1.0 μ F or more

Output Capacitors

- 3.3 μ F (Murata) GRM219B31A335KE18B
- 2.2 μ F (Murata) GRM155B30J225M
- 1.0 μ F (Murata) GRM155B31A105KE15

TEST CIRCUITS

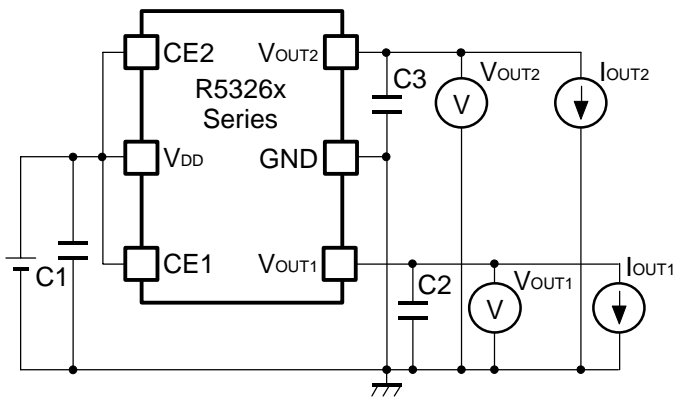

C1=Ceramic 1.0 μ F
C2,C3=refer to the term of the external capacitors

Fig.1 Standard test Circuit

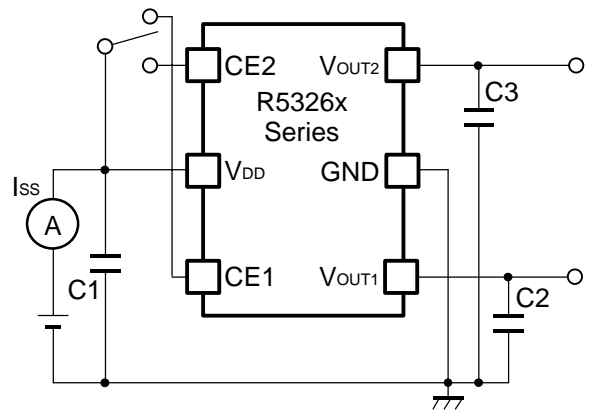

C1=Ceramic 1.0 μ F
C2,C3=refer to the term of the external capacitors

Fig.2 Supply Current Test Circuit

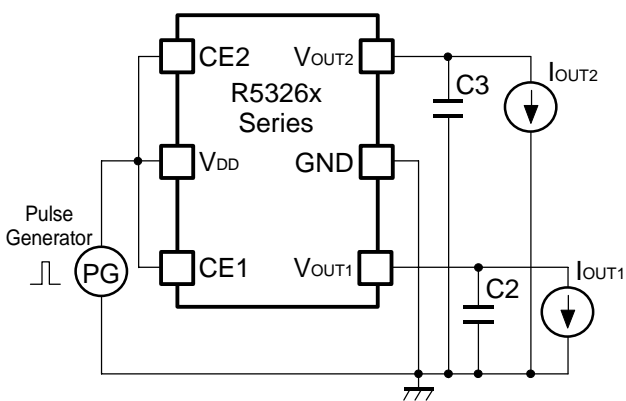

C2,C3= refer to the term of the external capacitors

Fig.3 Ripple Rejection, Line Transient Response Test Circuit

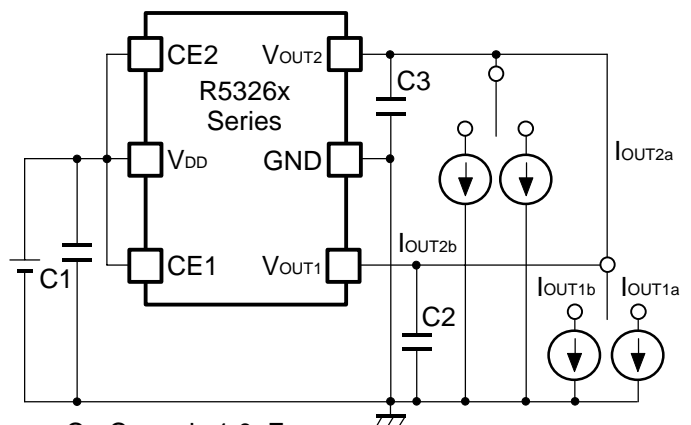

C1=Ceramic 1.0 μ F
C2,C3= refer to the term of the external capacitors

Fig.4 Load Transient Response Test Circuit

TYPICAL CHARACTERISTICS

1) Output Voltage vs. Output Current

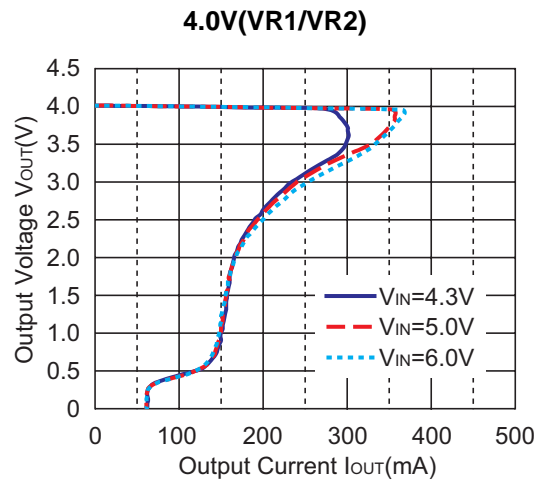
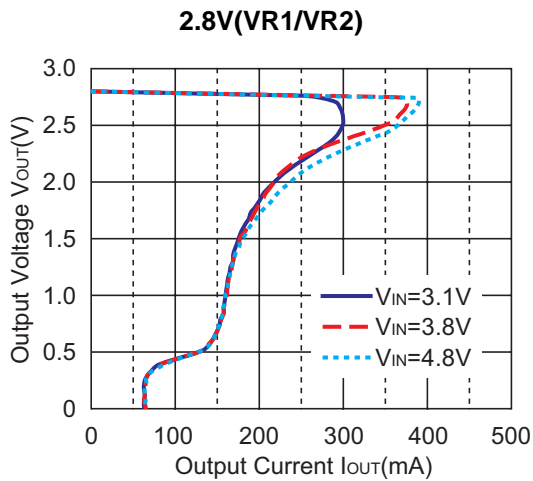
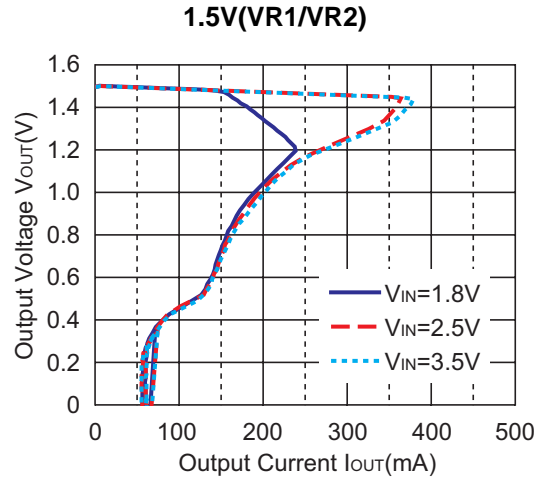
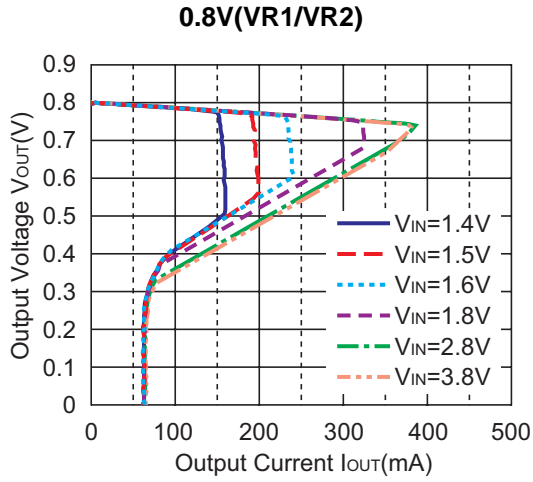

2) Input Voltage vs. Output Voltage

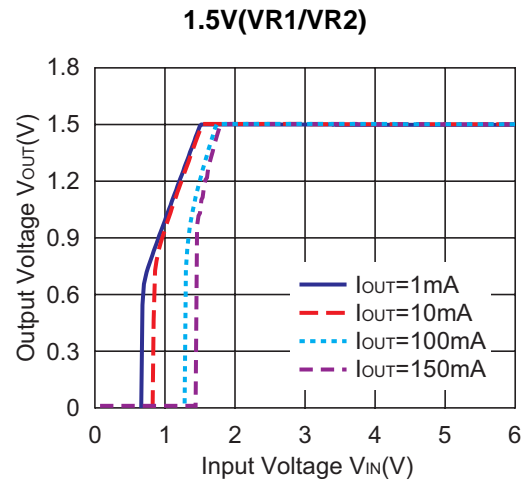
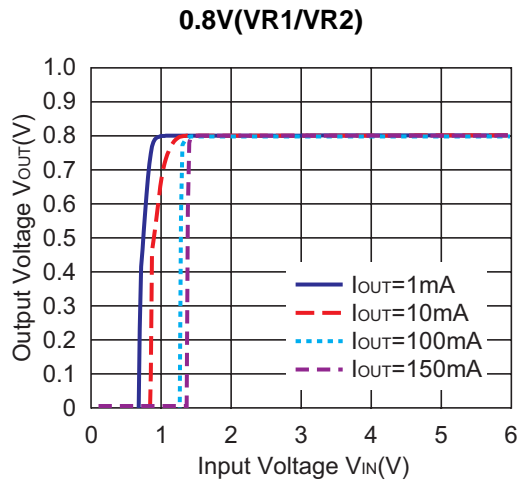

2.8V(VR1/VR2)

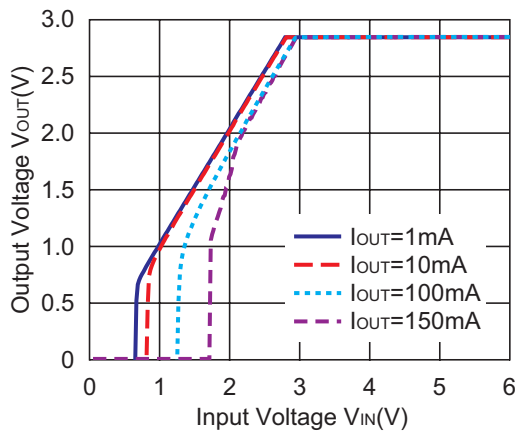

4.0V(VR1/VR2)

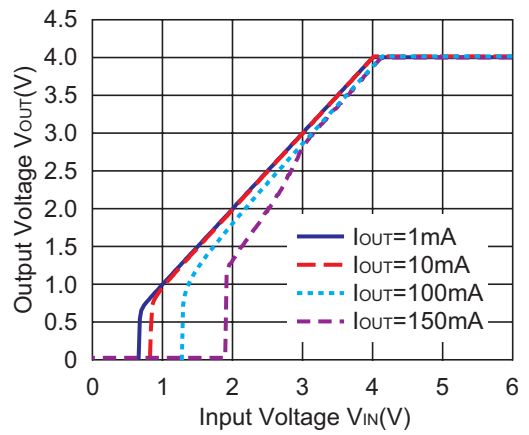

3) Supply Current vs. Input Voltage

0.8V(VR1/VR2)

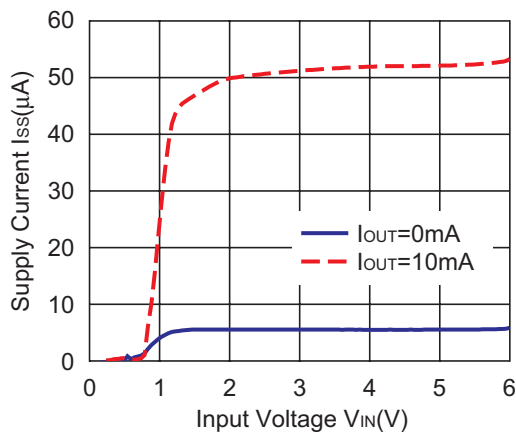

1.5V(VR1/VR2)

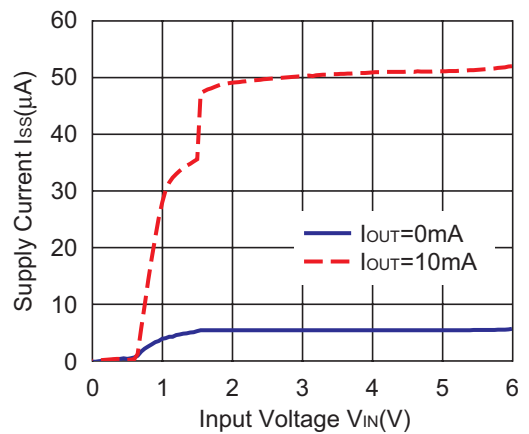

2.8V(VR1/VR2)

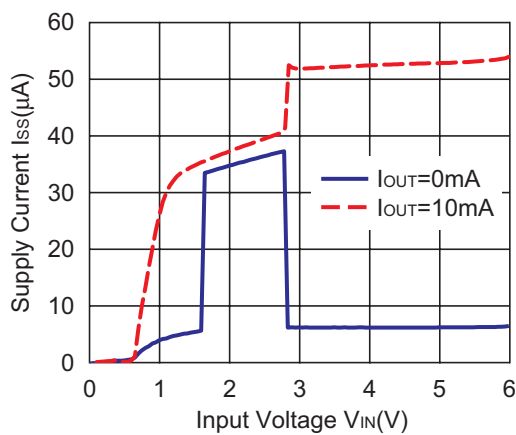

4.0V(VR1/VR2)

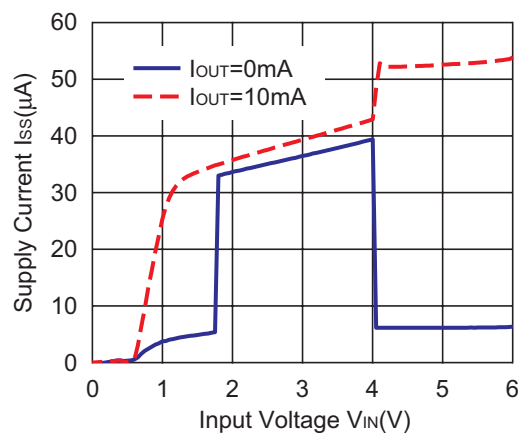

4) Supply current vs. Output current

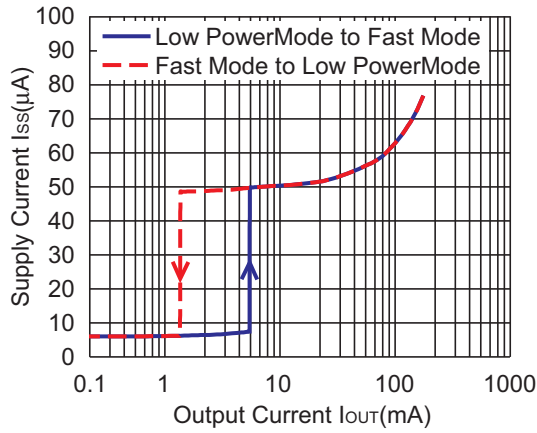

5) Output Voltage vs. Temperature

0.8V(VR1/VR2)

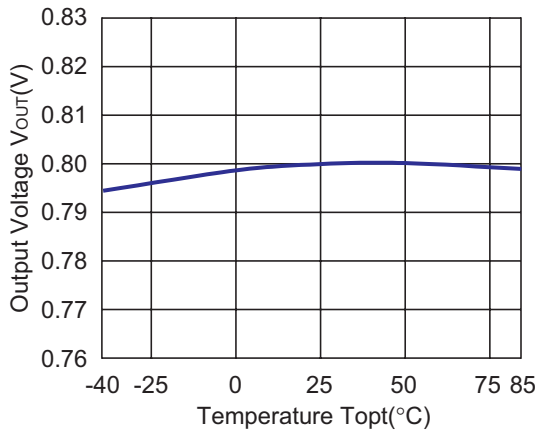

1.5V(VR1/VR2)

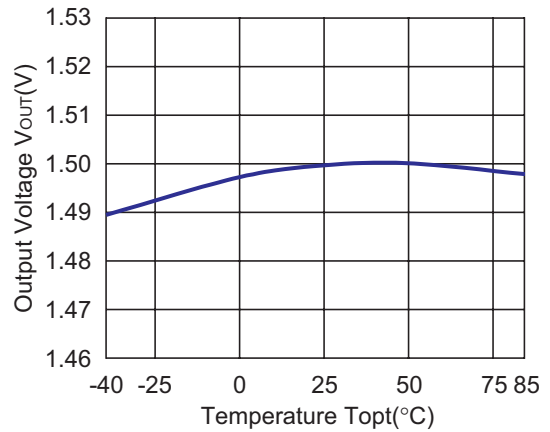

2.8V(VR1/VR2)

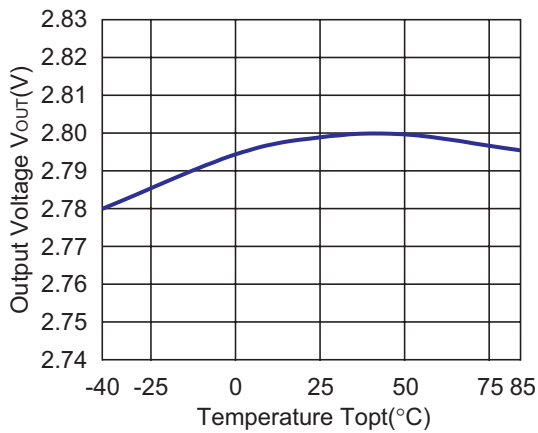

4.0V(VR1/VR2)

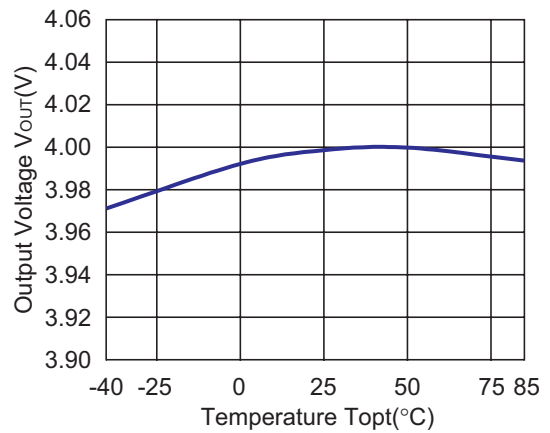

6) Supply Current vs. Temperature

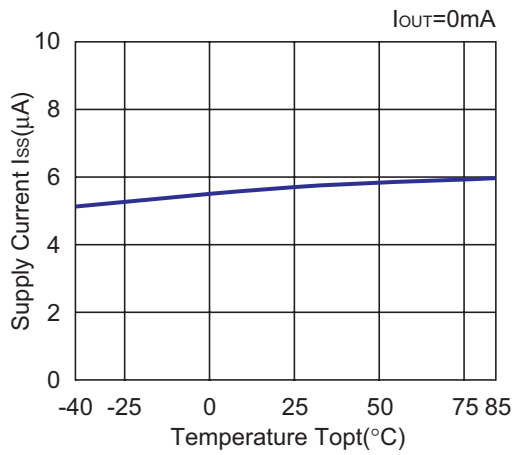

7) Dropout Voltage vs. Output Current

0.8V(VR1/VR2)

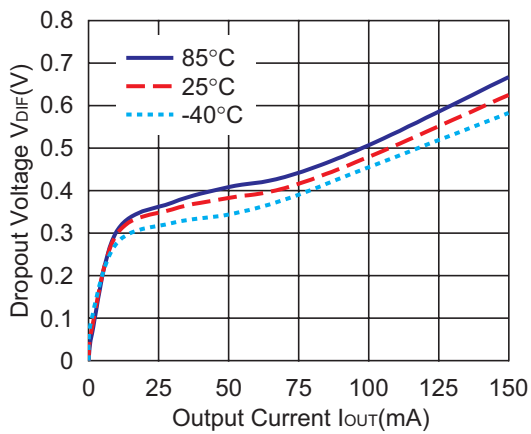

0.9V(VR1/VR2)

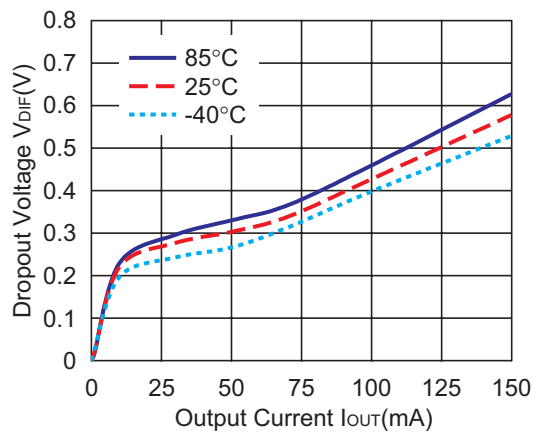

1.0V(VR1/VR2)

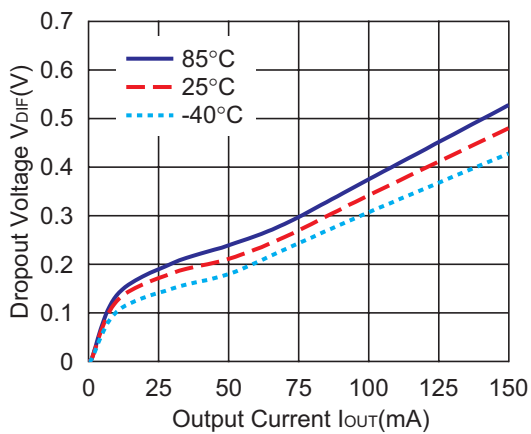

1.2V(VR1/VR2)

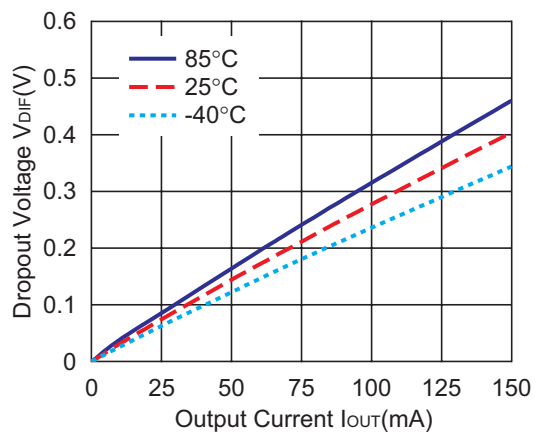

1.5V(VR1/VR2)

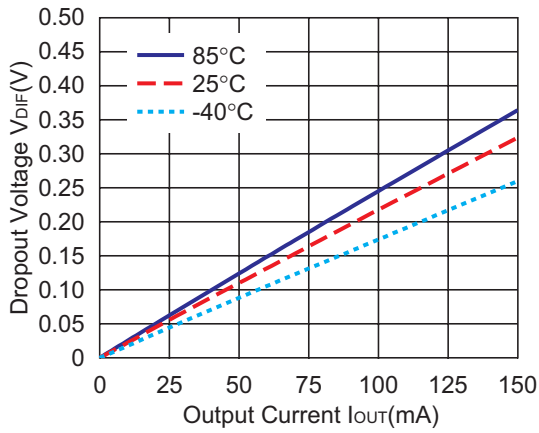

2.0V(VR1/VR2)

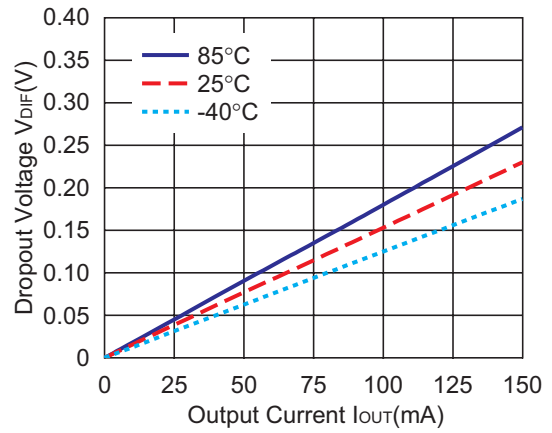

2.8V(VR1/VR2)

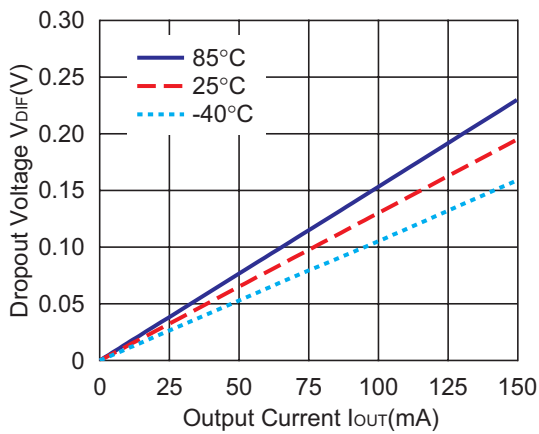

4.0V(VR1/VR2)

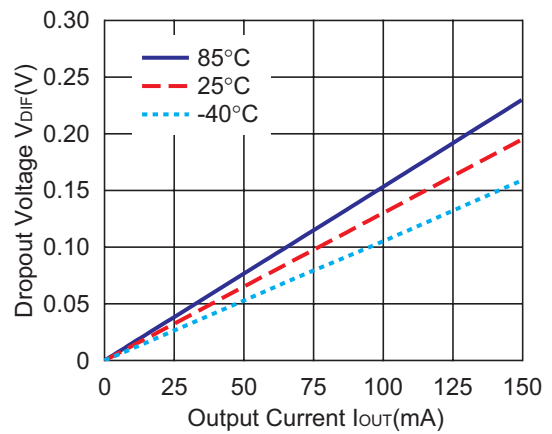

8) Dropout Voltage vs. Set Output Voltage

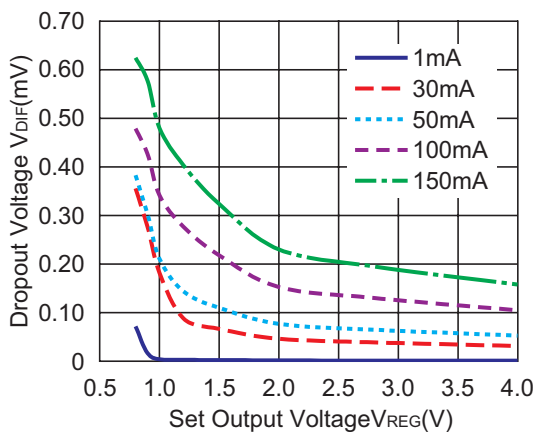

9) Ripple Rejection vs. Input Voltage

(Topt=25°C, Ripple 0.5Vp-p, CIN=none, COUT=Ceramic 1.0μF)

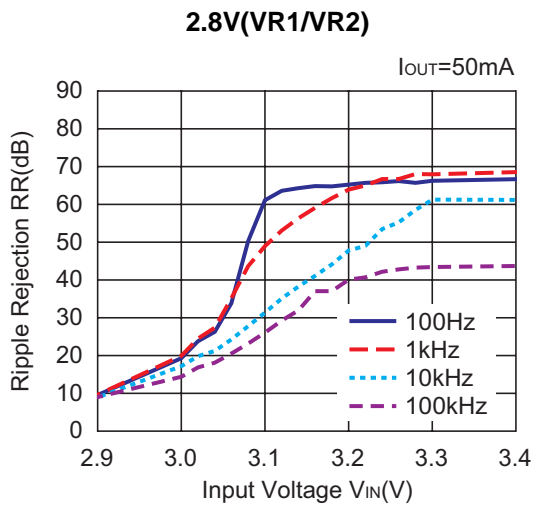
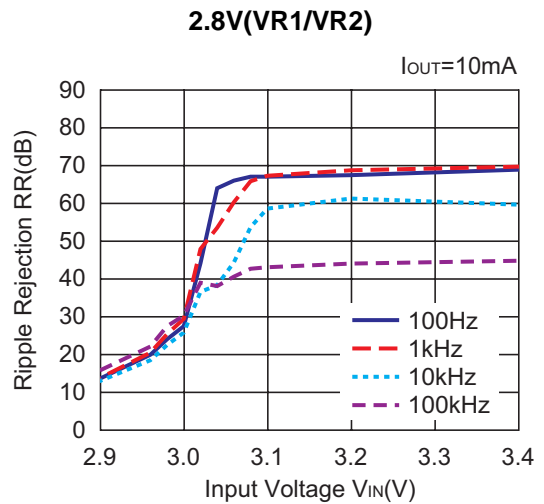
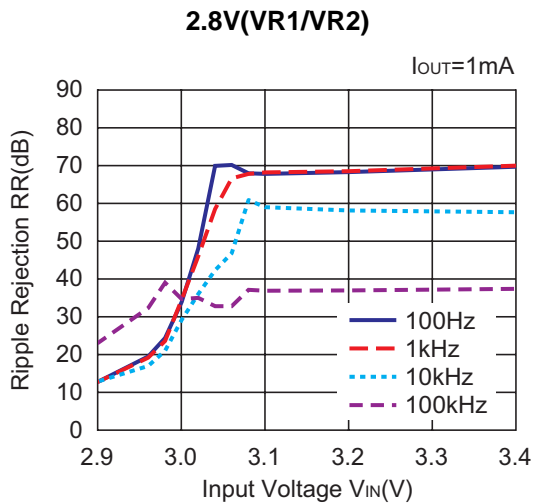

10) Minimum Operating Voltage

0.8V(VR1/VR2)

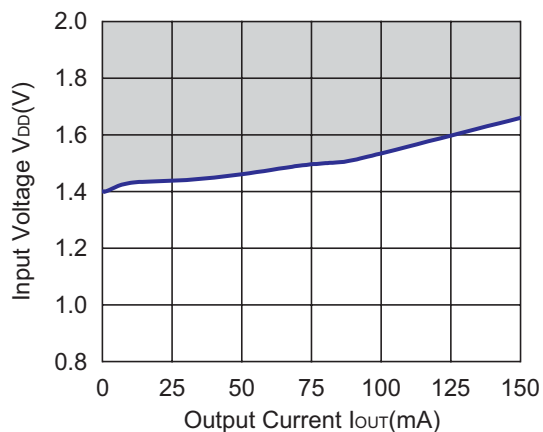

Hatched area is available for 0.8V output

11) Ripple Rejection vs Frequency (C_{IN}=none)

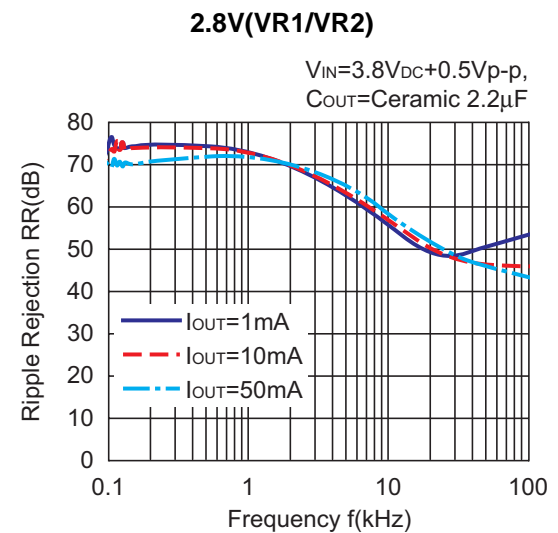
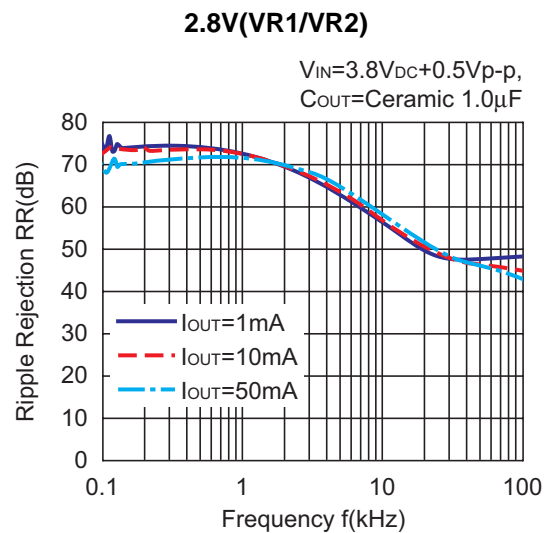
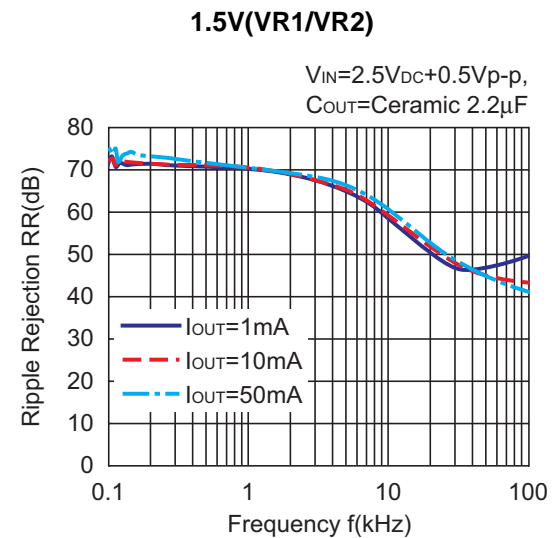
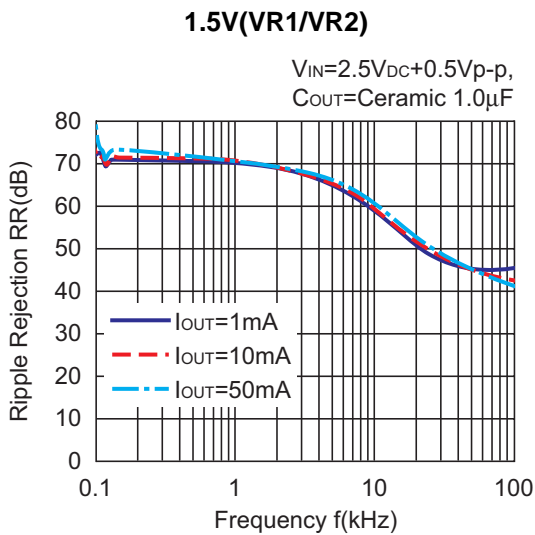
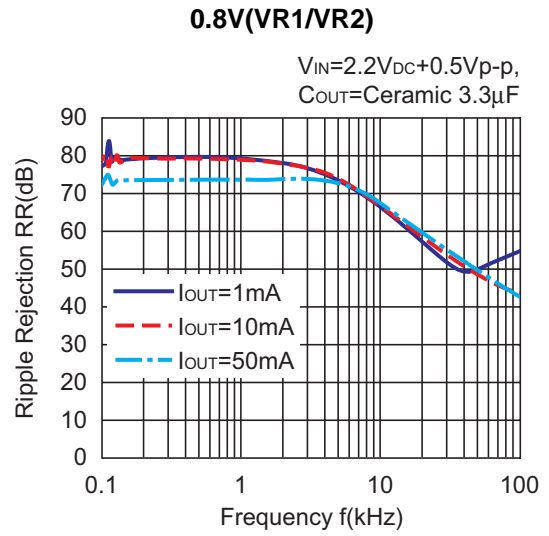
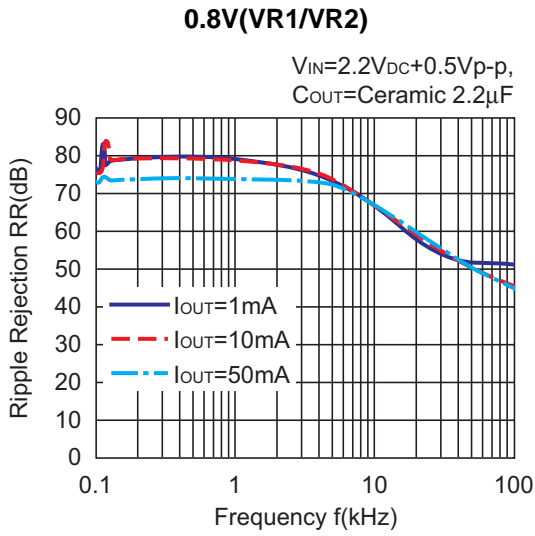

4.0V(VR1/VR2)

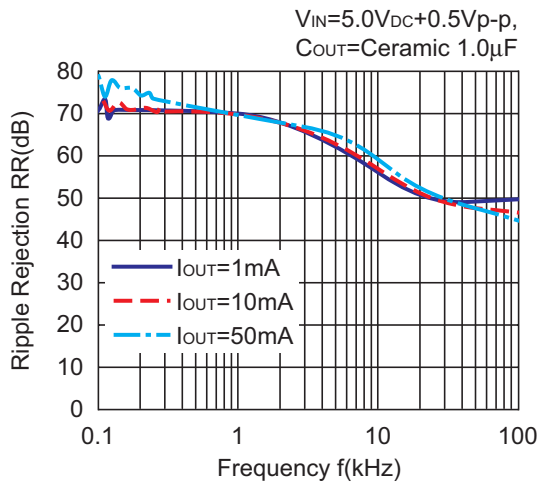

4.0V(VR1/VR2)

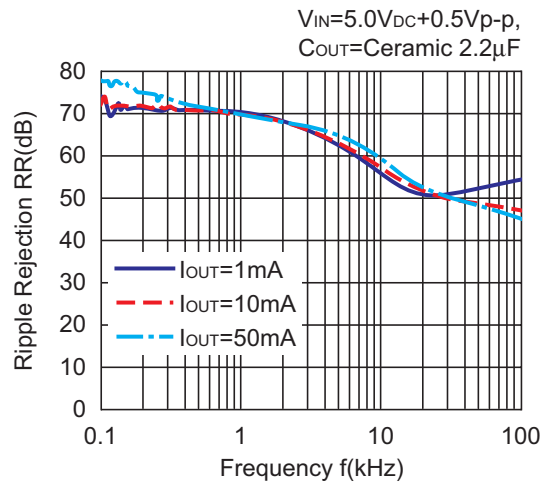

12) Input Transient Response ($I_{OUT}=30\text{mA}$, $t_r=t_f=5\mu\text{s}$, $C_{IN}=\text{none}$)

0.8V(VR1/VR2)

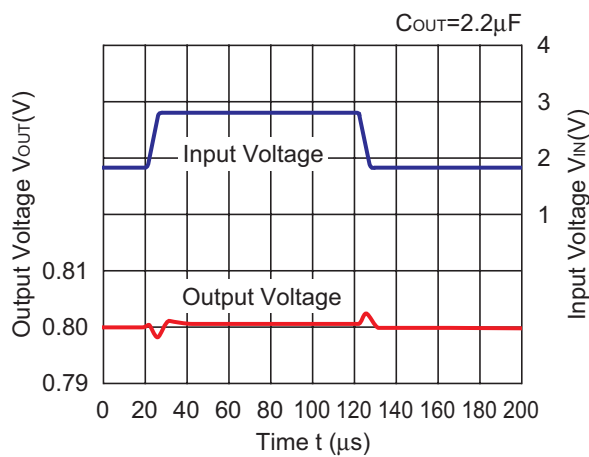

1.5V(VR1/VR2)

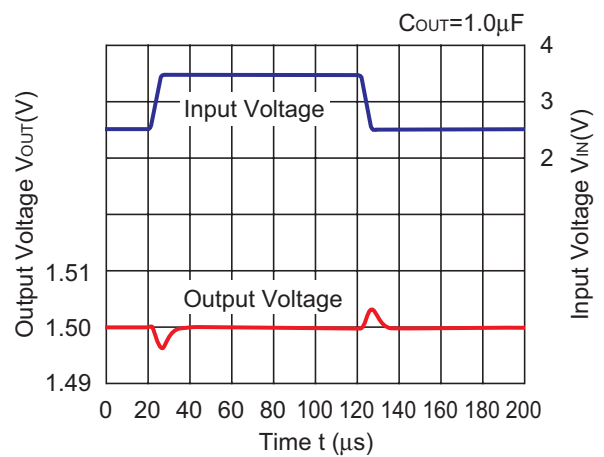

2.8V(VR1/VR2)

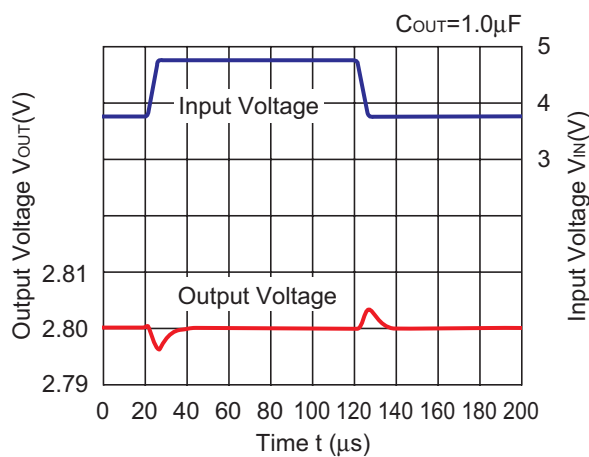

4.0V(VR1/VR2)

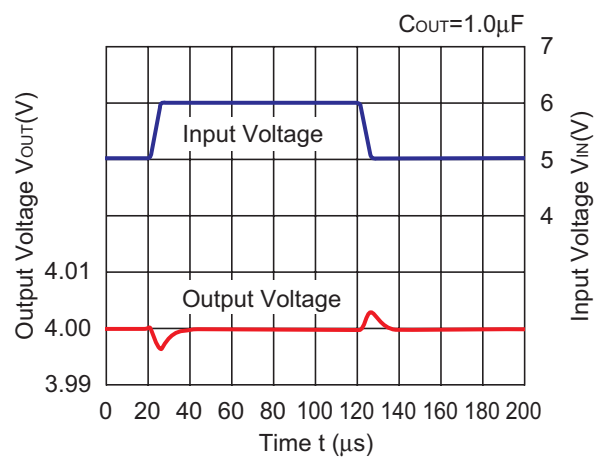

13) Load Transient Response1 ($t_r=t_f=0.5\mu s$, $C_{IN}=1.0\mu F$)

0.8V(VR1/VR2)

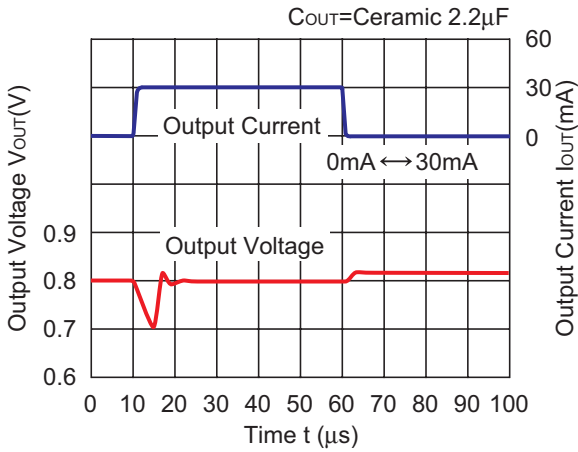

0.8V(VR1/VR2)

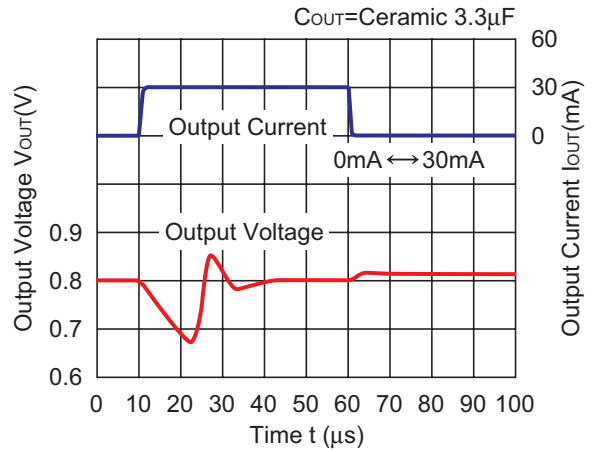

0.8V(VR1/VR2)

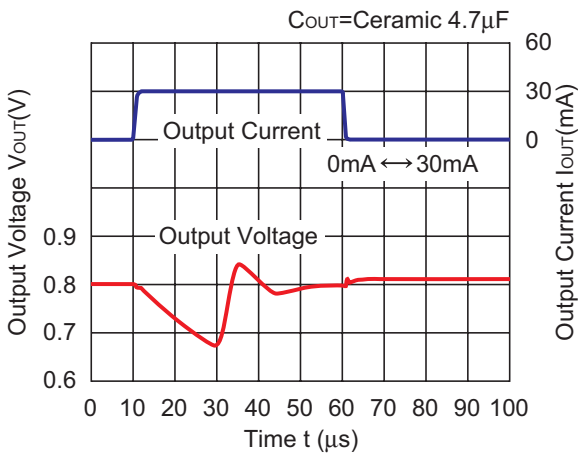

0.8V(VR1/VR2)

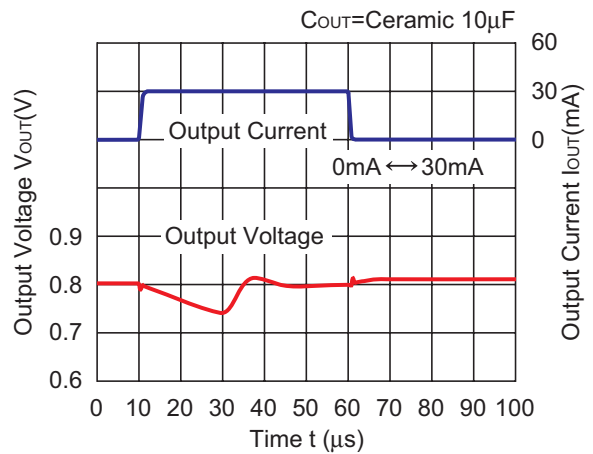

0.8V(VR1/VR2)

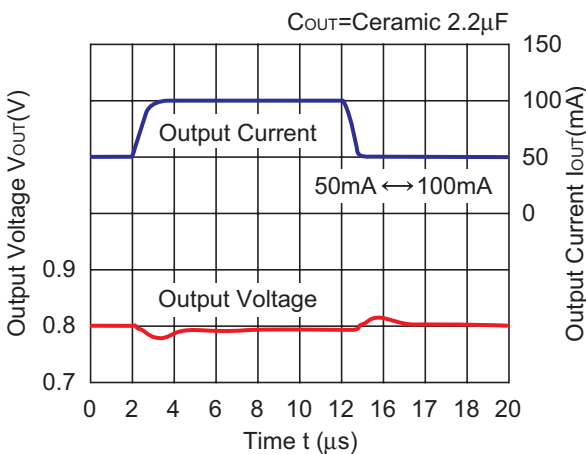

0.8V(VR1/VR2)

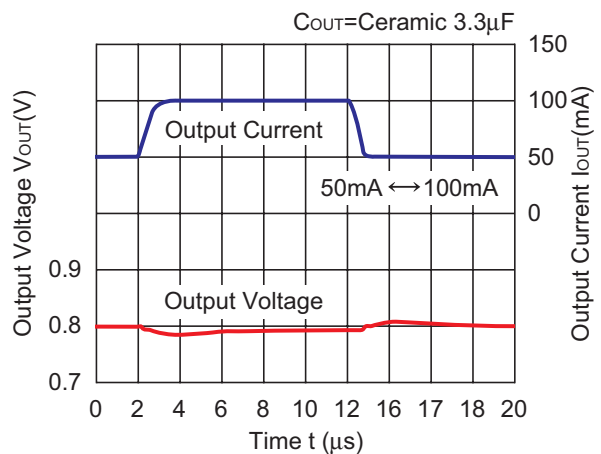

1.5V (VR1/VR2)

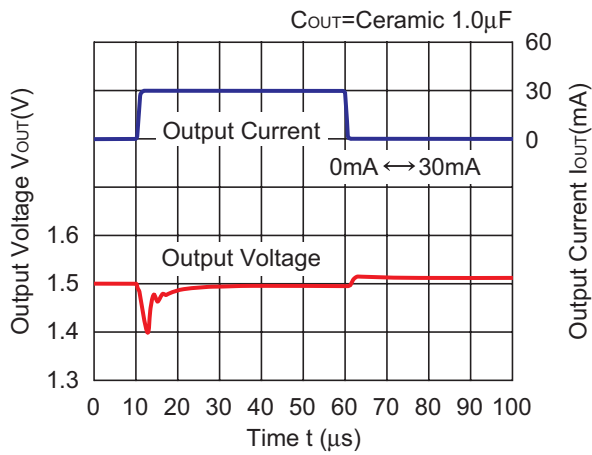

1.5V (VR1/VR2)

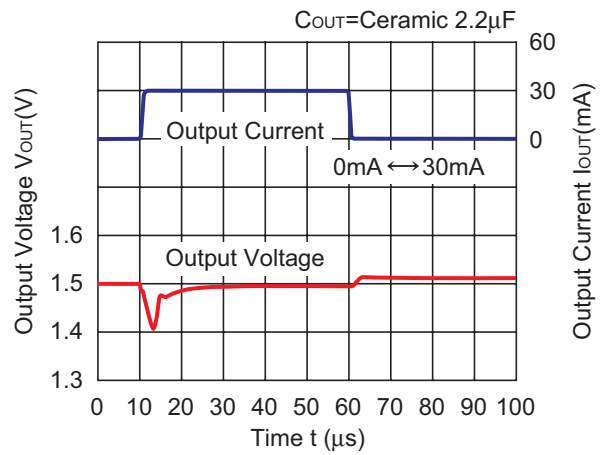

1.5V (VR1/VR2)

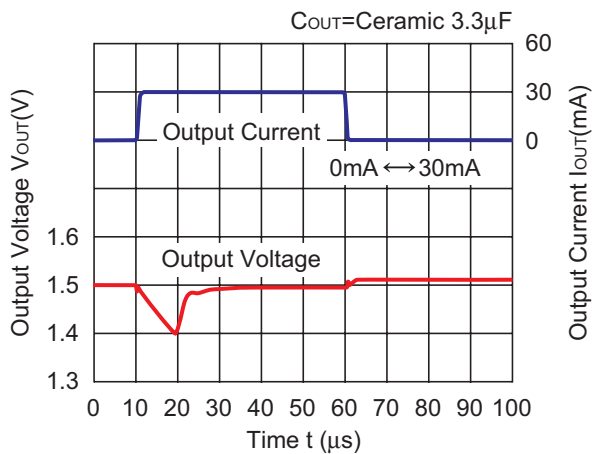

1.5V (VR1/VR2)

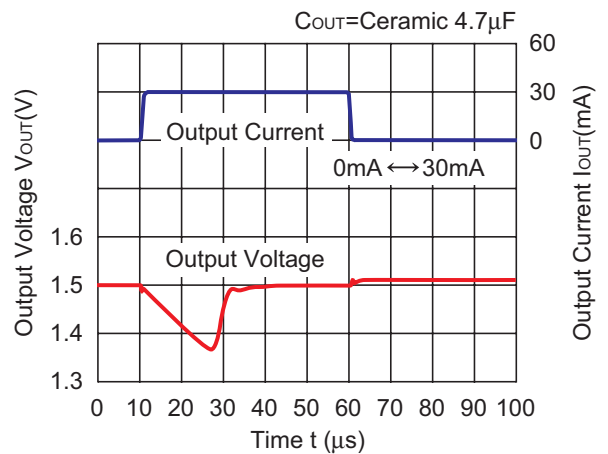

1.5V (VR1/VR2)

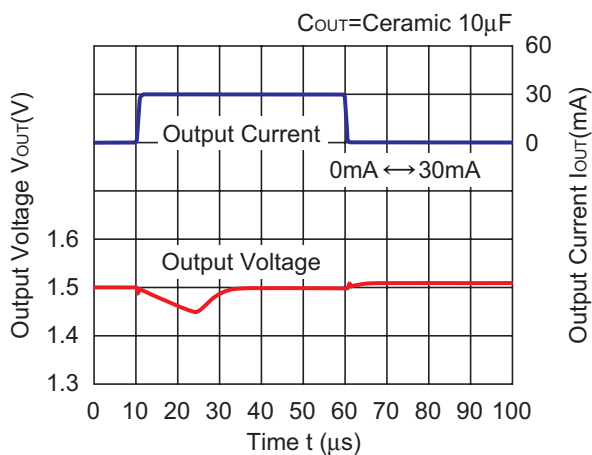

1.5V (VR1/VR2)

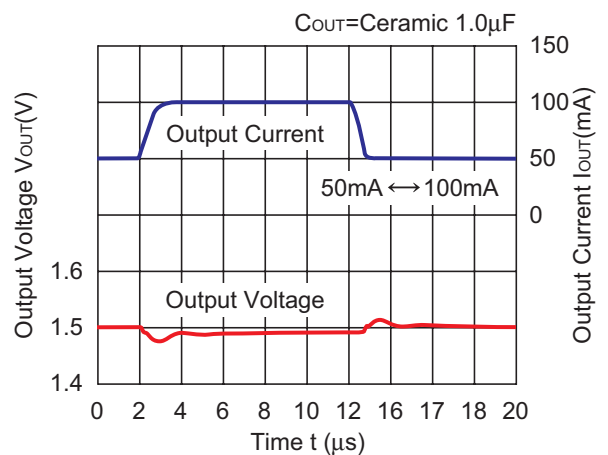

2.8V (VR1/VR2)

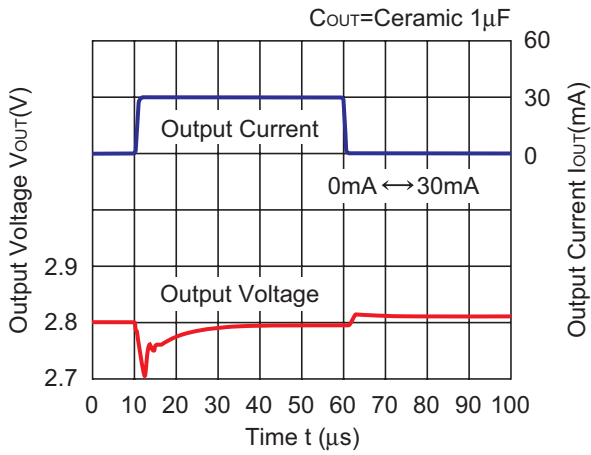

2.8V (VR1/VR2)

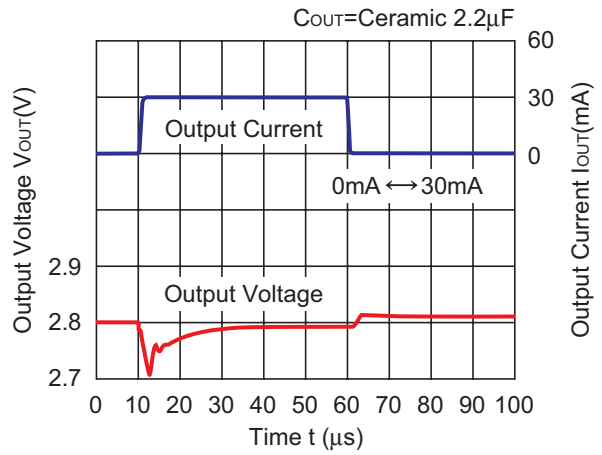

2.8V (VR1/VR2)

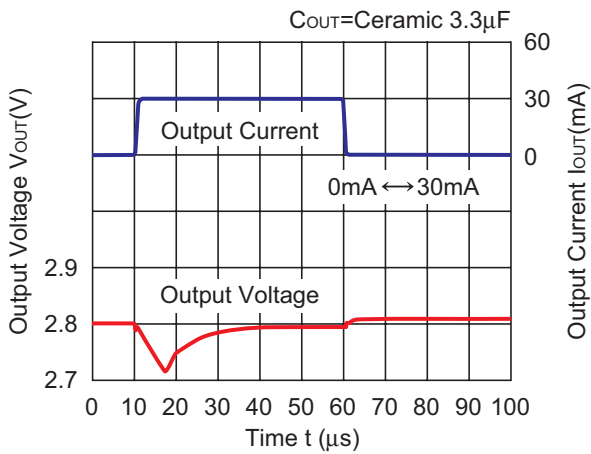

2.8V (VR1/VR2)

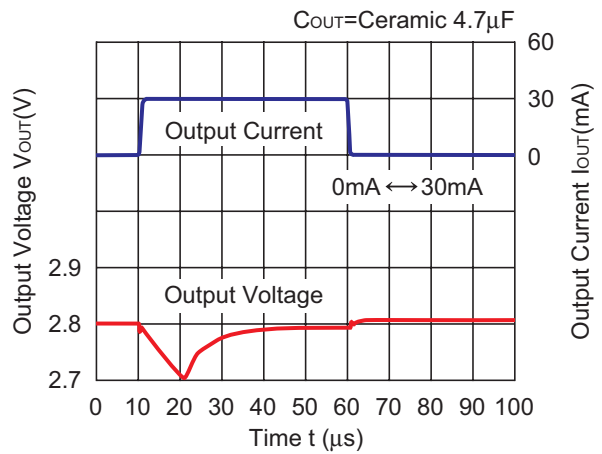

2.8V (VR1/VR2)

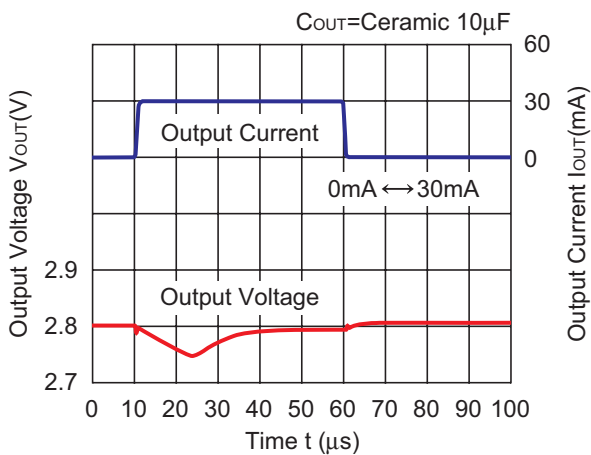

2.8V (VR1/VR2)

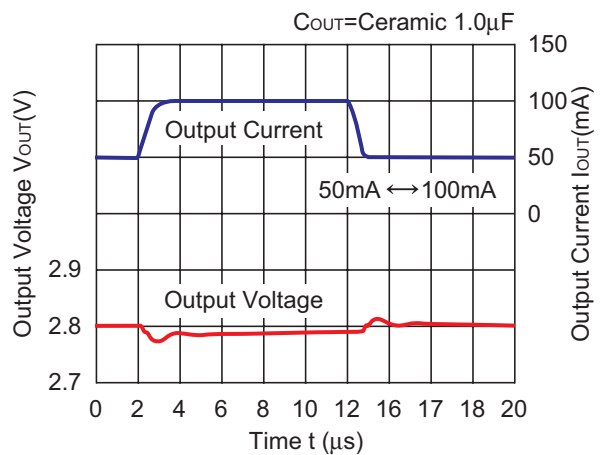

4.0V (VR1/VR2)

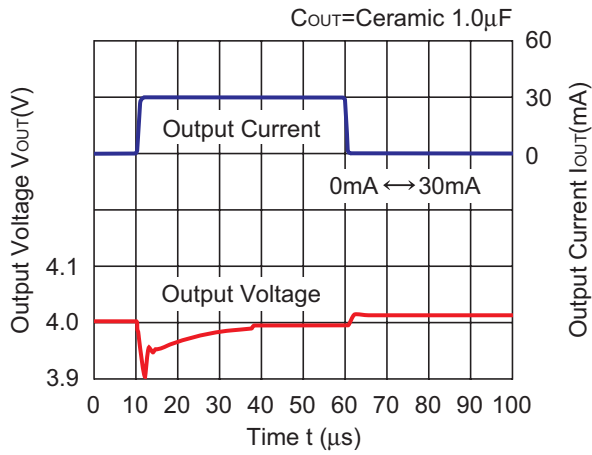

4.0V (VR1/VR2)

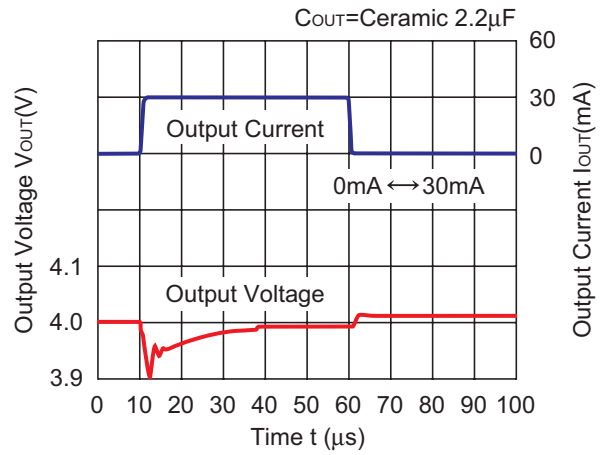

4.0V (VR1/VR2)

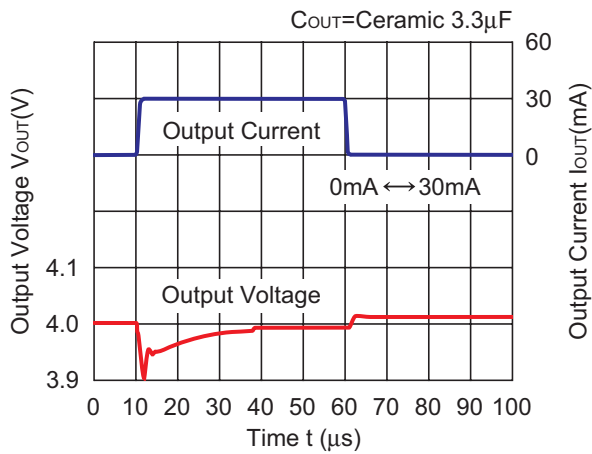

4.0V (VR1/VR2)

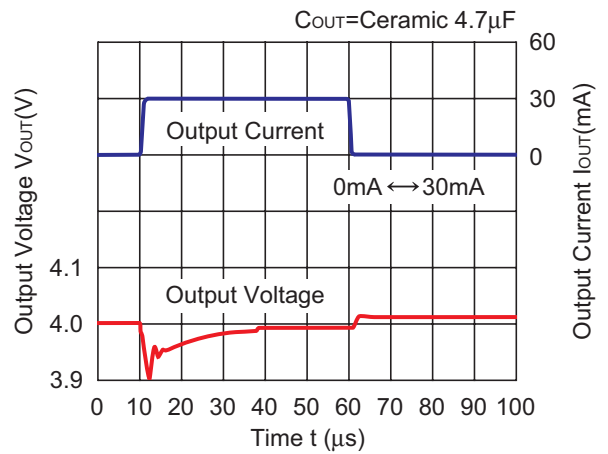

4.0V (VR1/VR2)

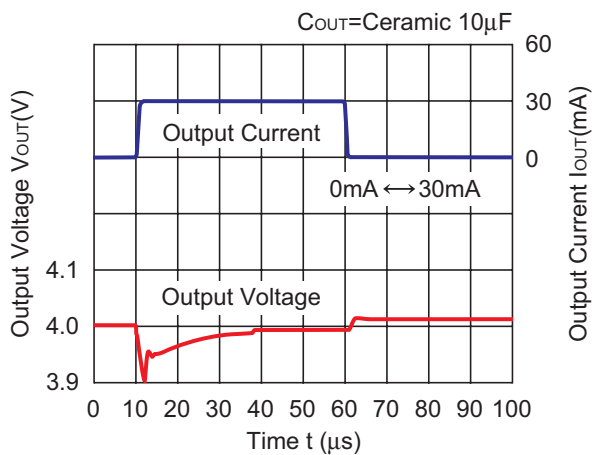

4.0V (VR1/VR2)

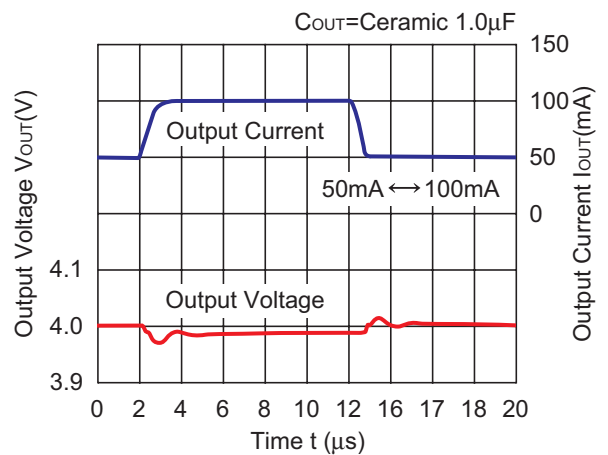

14) Load Transient Response2 ($t_r=t_f=0.5\mu s$, $C_{IN}=1.0\mu F$)

2.8V(VR1/VR2)

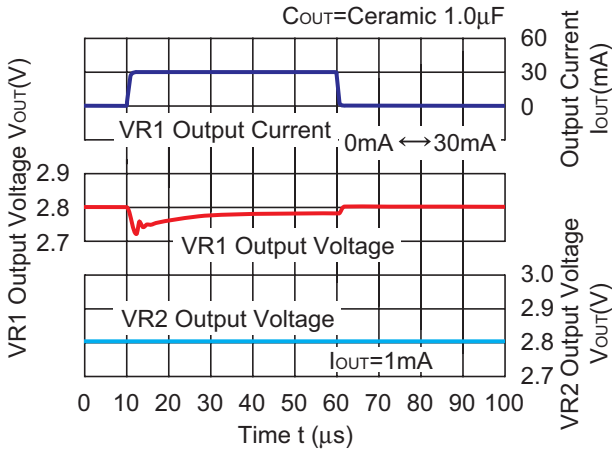

2.8V(VR1/VR2)

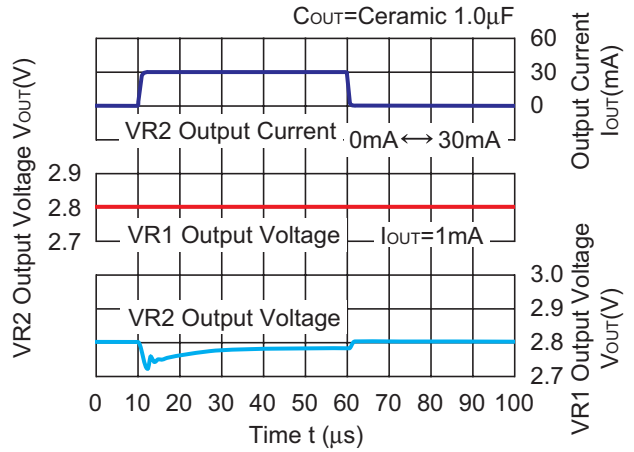

2.8V(VR1/VR2)

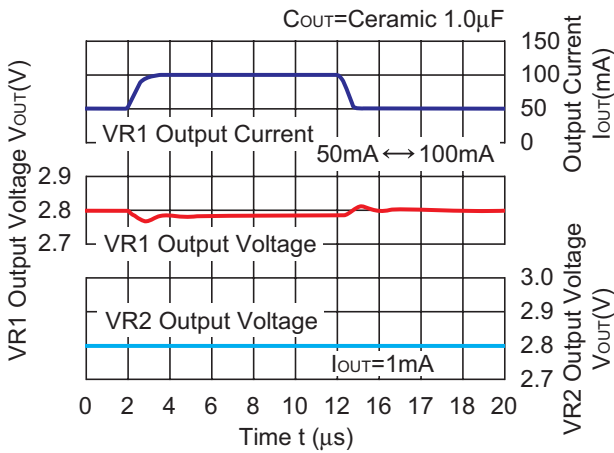

2.8V(VR1/VR2)

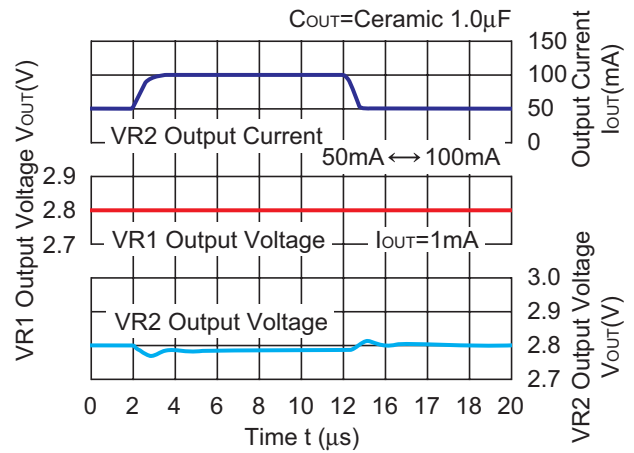

15) Load Transient Response3 ($t_r=t_f=10ns$)

3.0V(VR1/VR2)

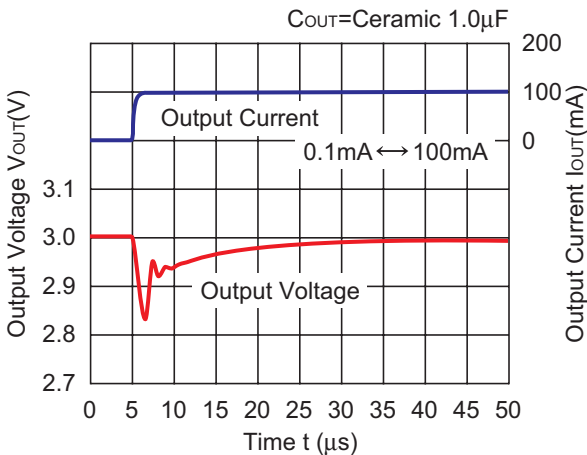

16) Turn on speed with CE Pin (C_{IN} =Ceramic 1.0 μ F)

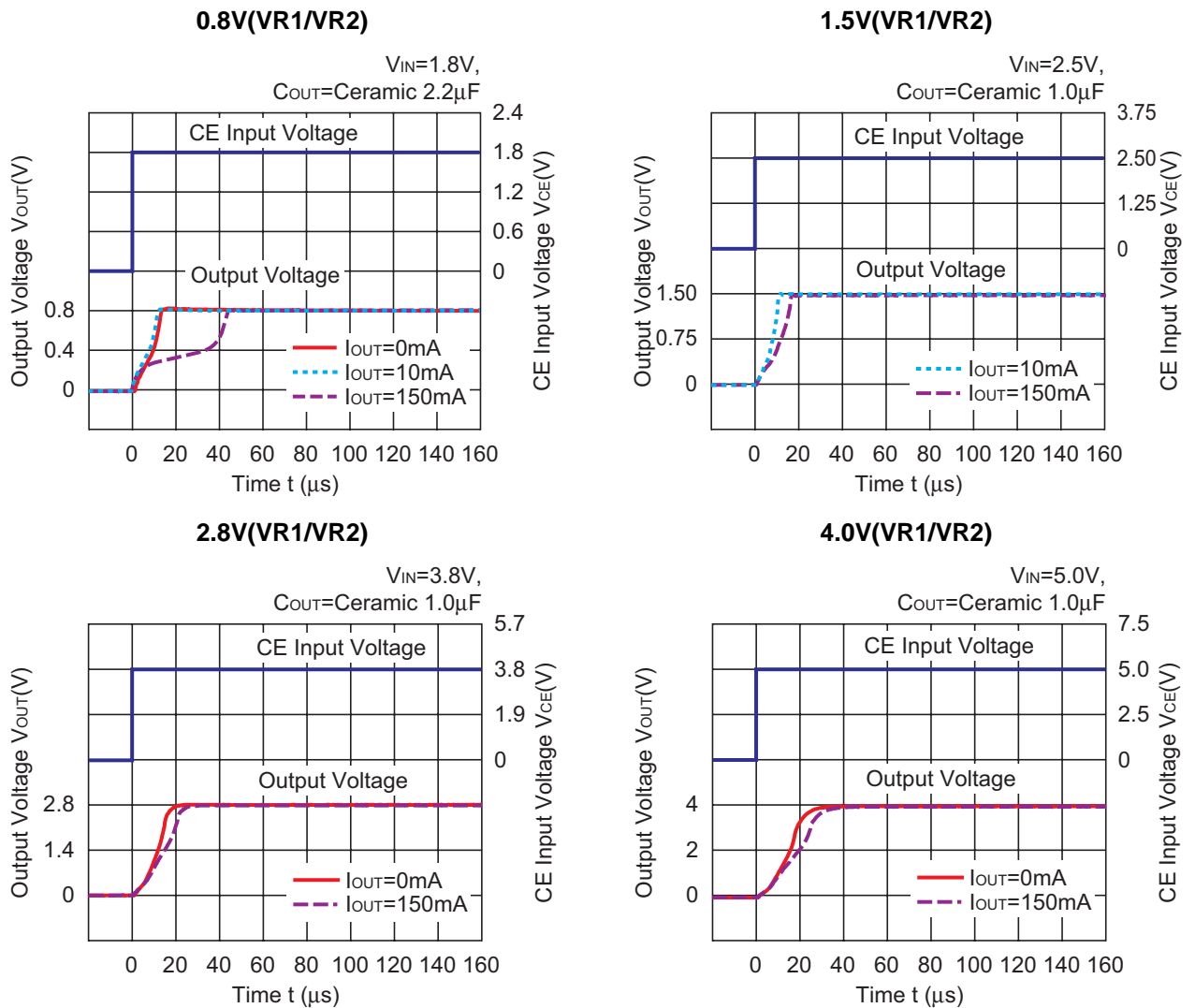

17) Turn off speed with CE Pin (C_{IN} =Ceramic 1.0 μ F)

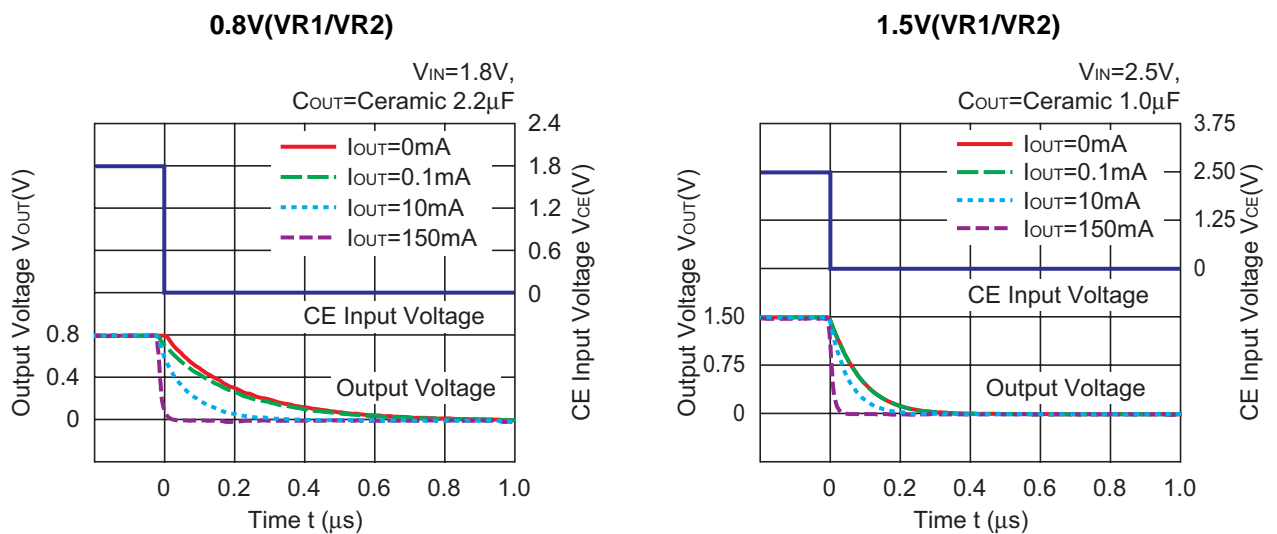

2.8V(VR1/VR2)

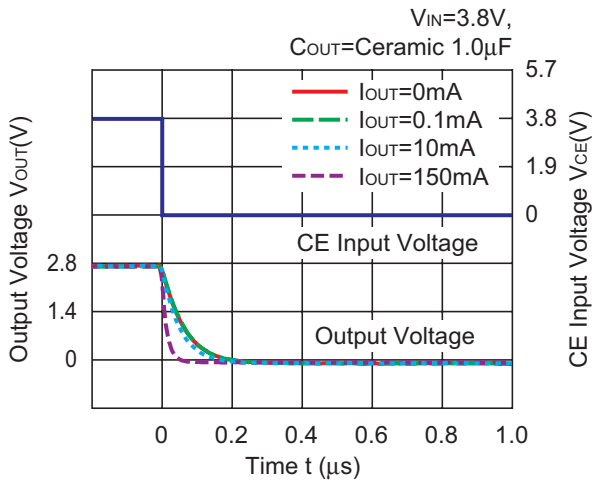

4.0V(VR1/VR2)

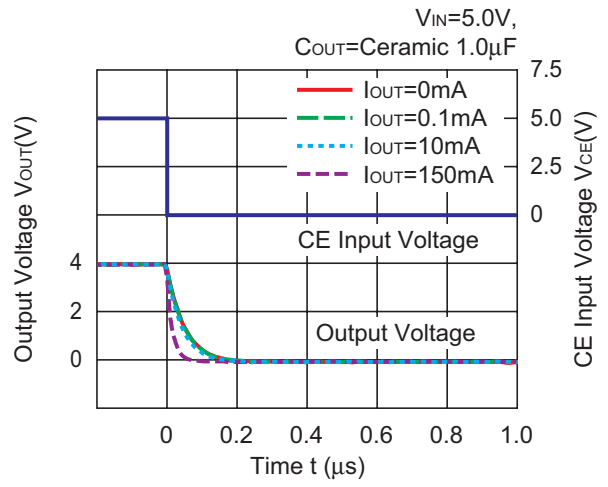

15) ESR vs. Output Current

(Inside area of the borders means the stable area. C_{IN} =Ceramic 1.0 μ F)

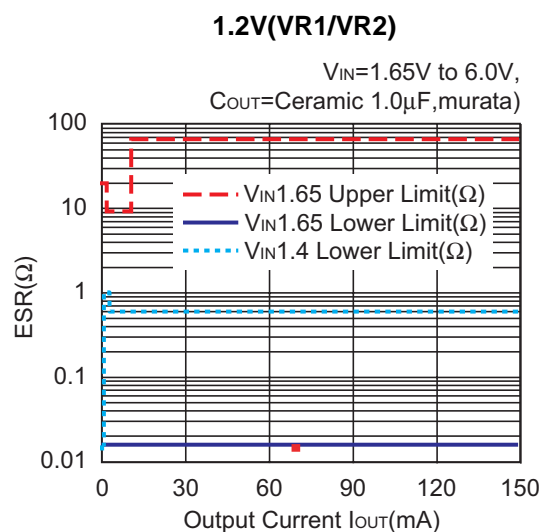
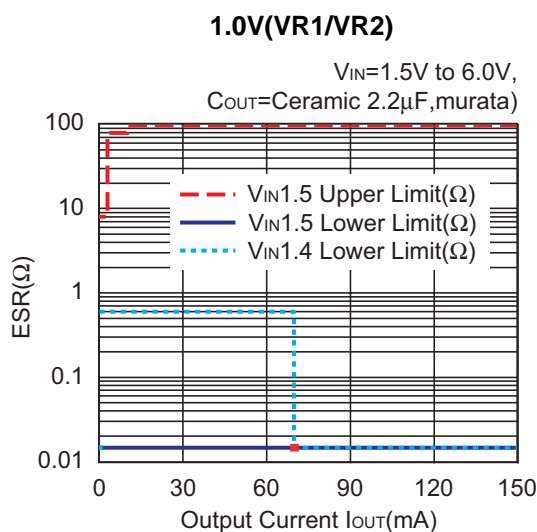
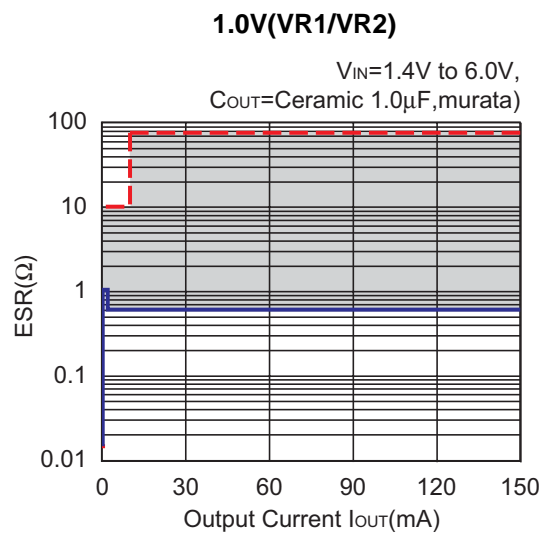
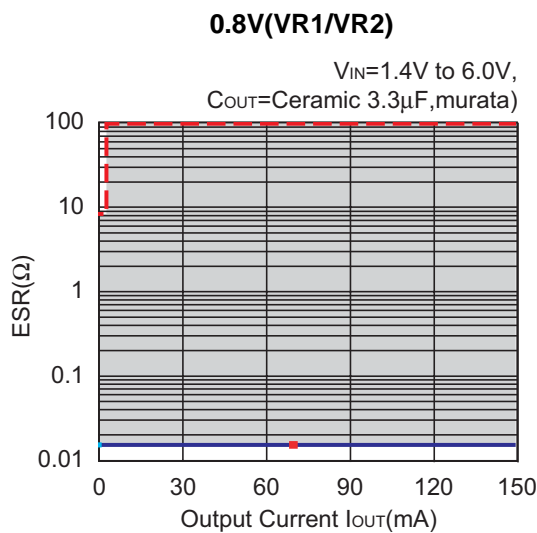
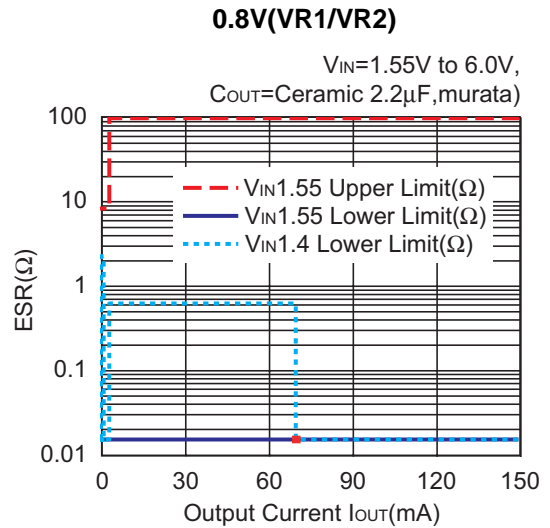
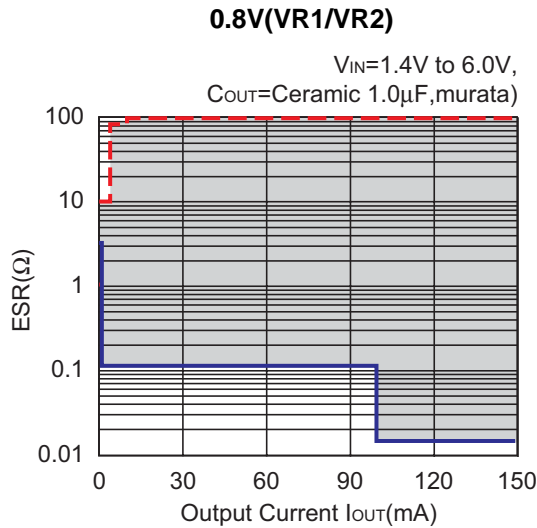

1.2V(VR1/VR2)

$V_{IN}=1.5V$ to $6.0V$,
 $C_{OUT}=\text{Ceramic } 2.2\mu\text{F, murata}$

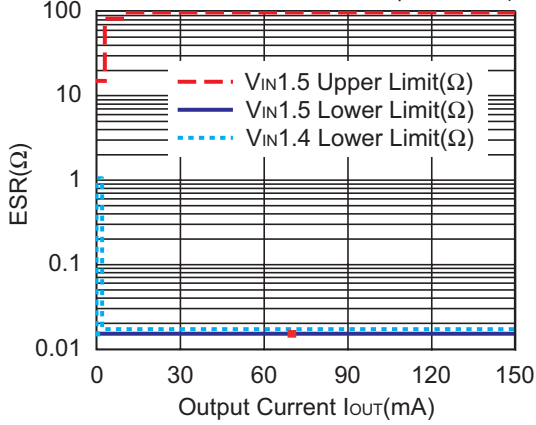

1.2V(VR1/VR2)

$V_{IN}=1.4V$ to $6.0V$,
 $C_{OUT}=\text{Ceramic } 3.3\mu\text{F, murata}$

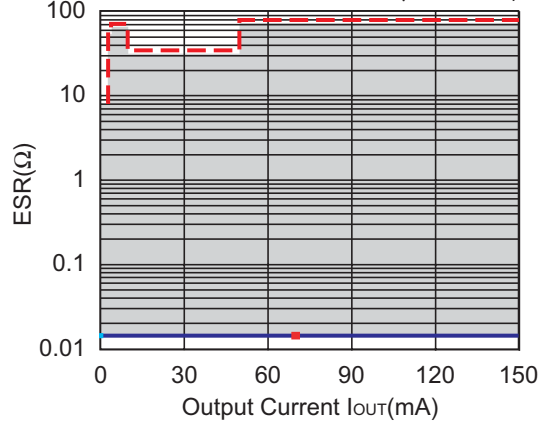

2.8V(VR1/VR2)

$V_{IN}=2.8V$ to $6.0V$,
 $C_{OUT}=\text{Ceramic } 1.0\mu\text{F, murata}$

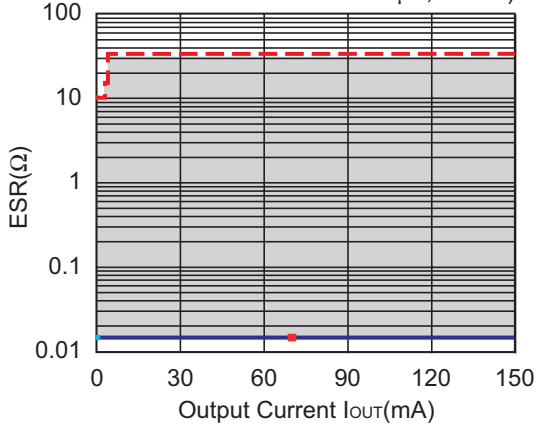

4.0V(VR1/VR2)

$V_{IN}=4.0V$ to $6.0V$,
 $C_{OUT}=\text{Ceramic } 1.0\mu\text{F, murata}$

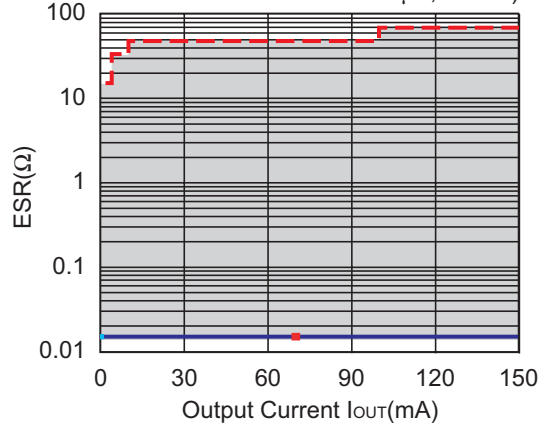

0.8V(VR1/VR2)

$V_{IN}=1.5V$ to $6.0V$,
 $C_{OUT}=\text{Ceramic } 2.2\mu\text{F, kyocera}$

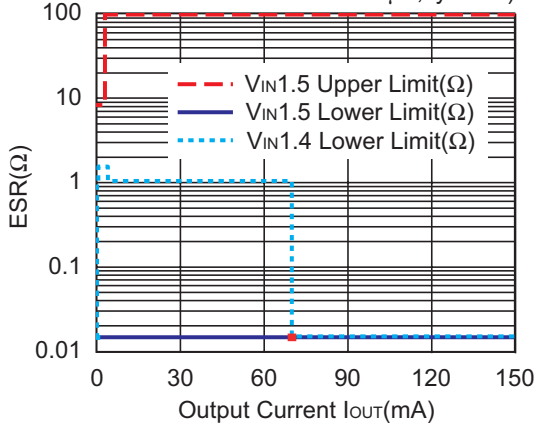

1.0V(VR1/VR2)

$V_{IN}=1.5V$ to $6.0V$,
 $C_{OUT}=\text{Ceramic } 2.2\mu\text{F, kyocera}$

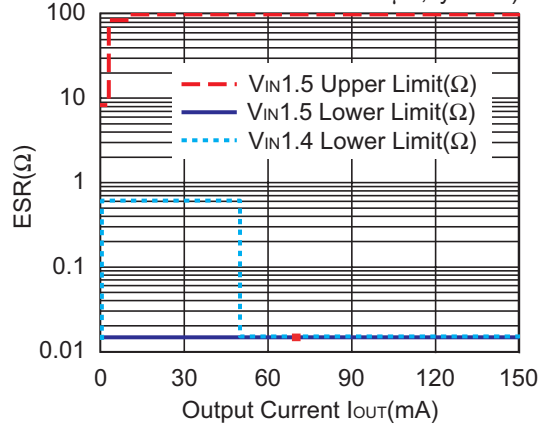

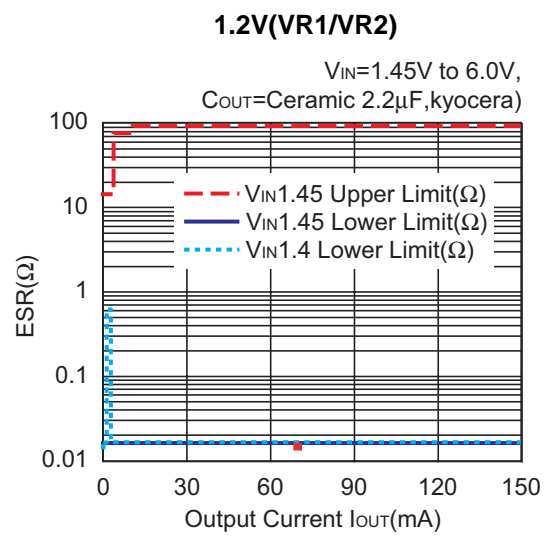

- SOT-23-6 (SC-74)

Unit: mm

PACKAGE DIMENSIONS

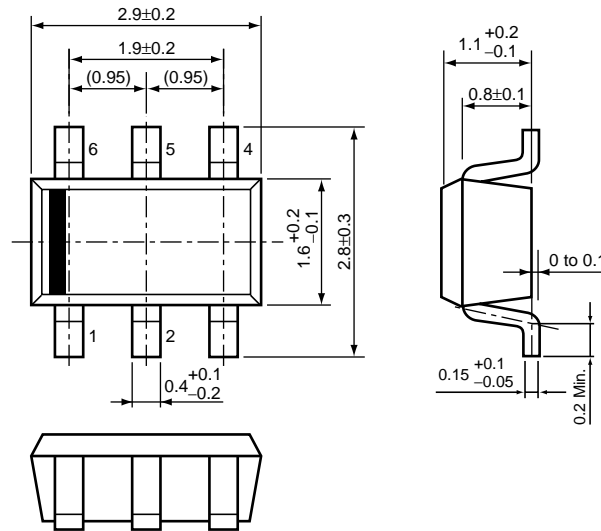

TAPING SPECIFICATION

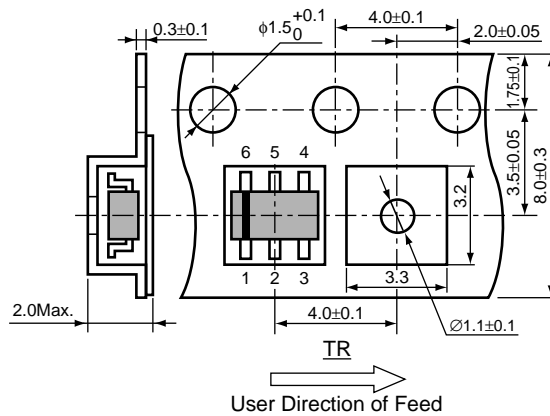

TAPING REEL DIMENSIONS REUSE REEL (EIAJ-RRM-08Bc)

(1reel=3000pcs)

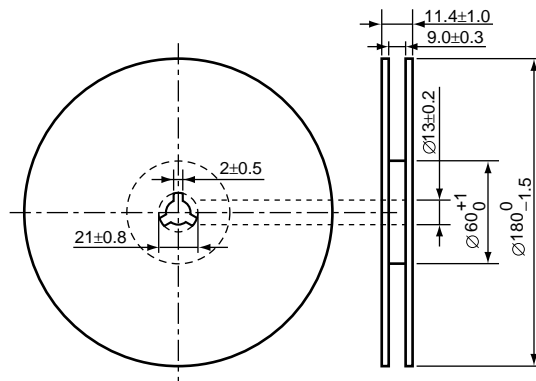

POWER DISSIPATION (SOT-23-6)

This specification is at mounted on board. Power Dissipation (P_D) depends on conditions of mounting on board. This specification is based on the measurement at the condition below:

Measurement Conditions

	Standard Land Pattern
Environment	Mounting on Board (Wind velocity=0m/s)
Board Material	Glass cloth epoxy plactic (Double sided)
Board Dimensions	40mm × 40mm × 1.6mm
Copper Ratio	Top side : Approx. 50% , Back side : Approx. 50%
Through-hole	φ0.5mm × 44pcs

Measurement Result

($T_{opt}=25^{\circ}C, T_{jmax}=125^{\circ}C$)

	Standard Land Pattern	Free Air
Power Dissipation	420mW	250mW
Thermal Resistance	$\theta_{ja}=(125-25^{\circ}C)/0.42W=263^{\circ}C/W$	400°C/W

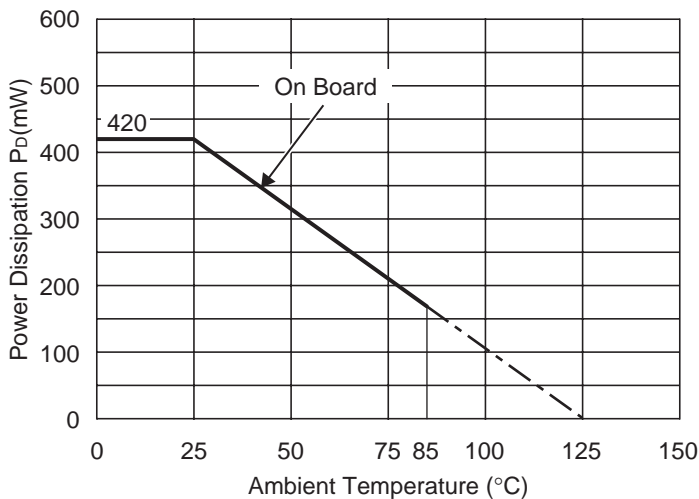

Power Dissipation

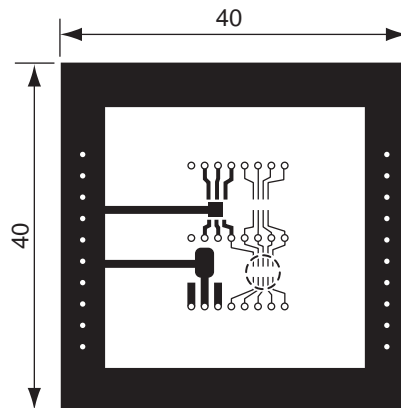

Measurement Board Pattern

○ IC Mount Area Unit : mm

RECOMMENDED LAND PATTERN

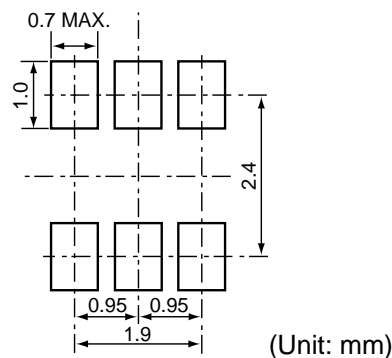

● PLP1820-6

Unit: mm

PACKAGE DIMENSIONS

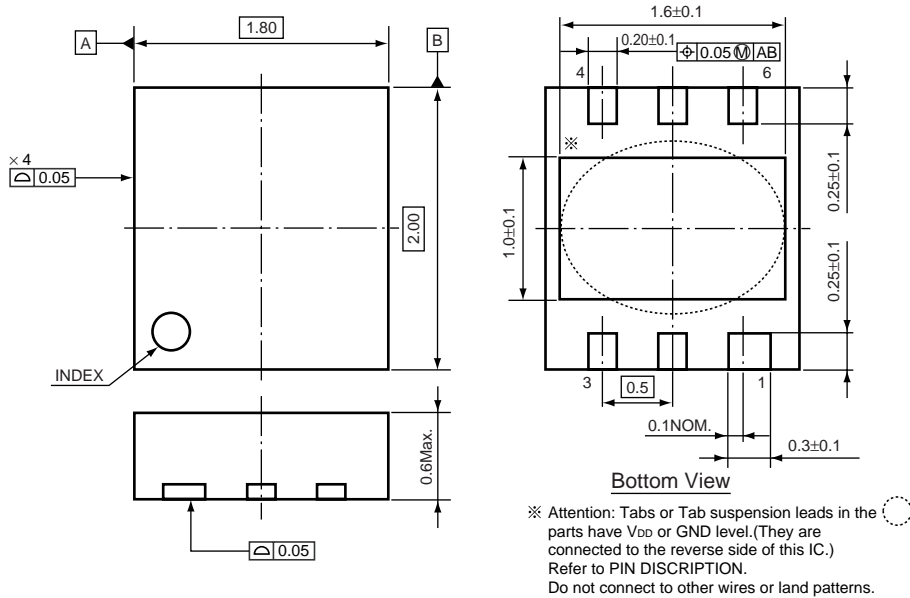

TAPING SPECIFICATION

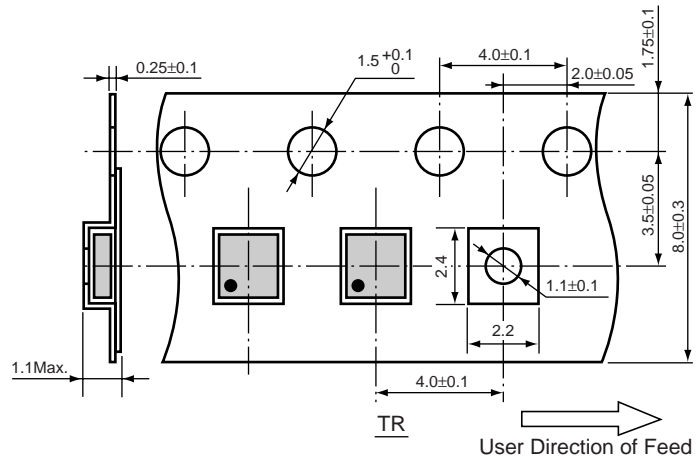

TAPING REEL DIMENSIONS REUSE REEL (EIAJ-RRM-08Bc)

(1reel=5000pcs)
 (R5323K,R5325K : 1reel=3000pcs)

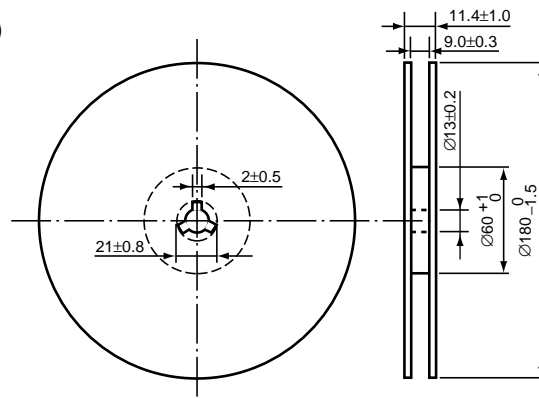

POWER DISSIPATION (PLP1820-6)

This specification is at mounted on board. Power Dissipation (P_D) depends on conditions of mounting on board. This specification is based on the measurement at the condition below:

Measurement Conditions

	Standard Land Pattern
Environment	Mounting on Board (Wind velocity=0m/s)
Board Material	Glass cloth epoxy plactic (Double sided)
Board Dimensions	40mm × 40mm × 1.6mm
Copper Ratio	Top side : Approx. 50% , Back side : Approx. 50%
Through-hole	φ0.54mm × 30pcs

Measurement Result ($T_{opt}=25^{\circ}C, T_{jmax}=125^{\circ}C$)

	Standard Land Pattern
Power Dissipation	880mW
Thermal Resistance	$\theta_{ja}=(125-25^{\circ}C)/0.88W=114^{\circ}C/W$

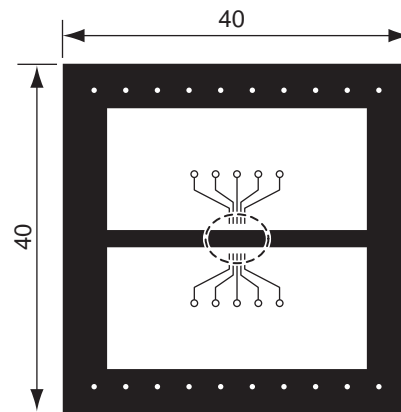
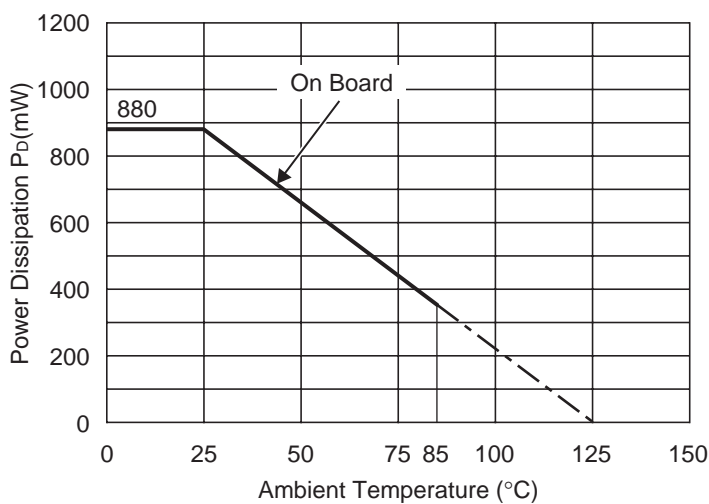

Measurement Board Pattern

○ IC Mount Area Unit : mm

RECOMMENDED LAND PATTERN

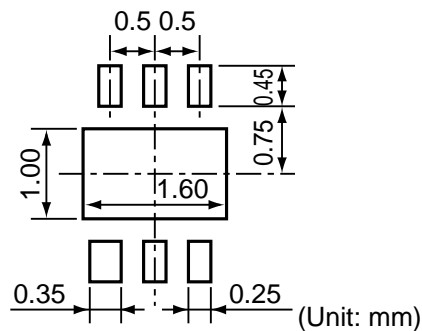

• WLCSP-6-P1

Unit: mm

PACKAGE DIMENSIONS

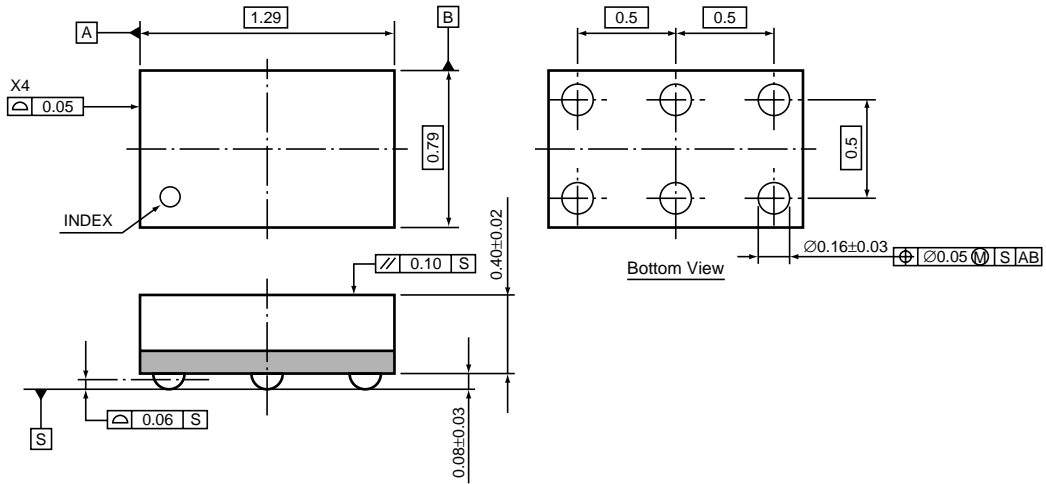

TAPING SPECIFICATION

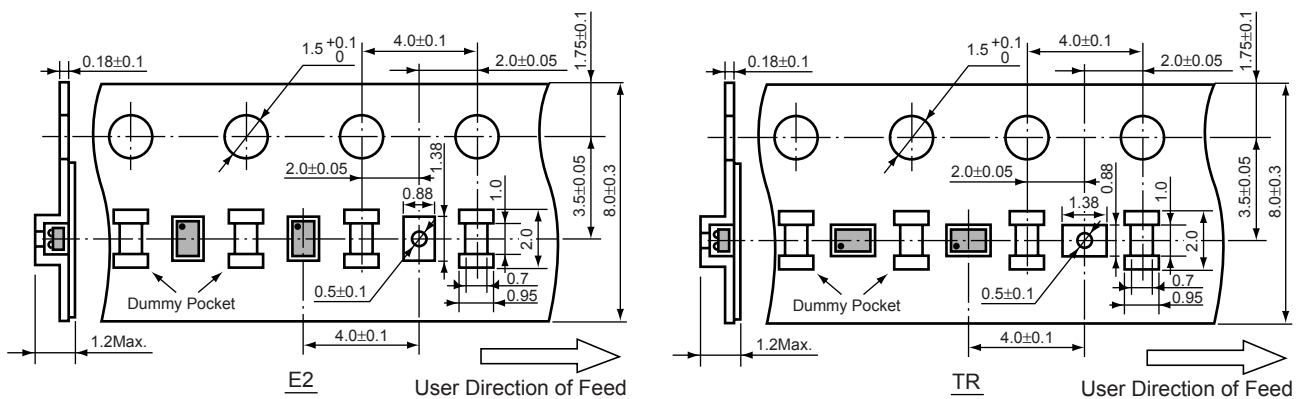

The TAPING SPECIFICATION becomes one kind in each product.
Please refer to SELECTION GUIDE for details.

TAPING REEL DIMENSIONS REUSE REEL (EIAJ-RRM-08Bc)

- (1reel=5000pcs : E2 Type)
- (1reel=3000pcs : TR Type)

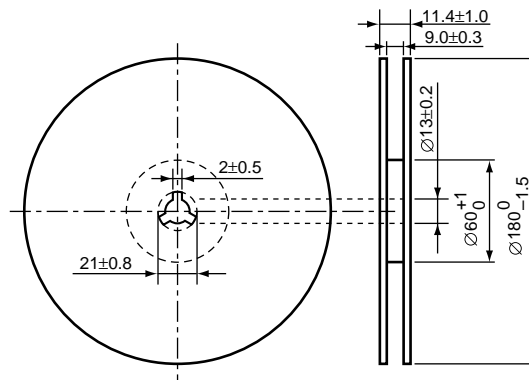

POWER DISSIPATION (WLCSP-6-P1)

This specification is at mounted on board. Power Dissipation (P_D) depends on conditions of mounting on board. This specification is based on the measurement at the condition below:

Measurement Conditions

	Standard Land Pattern
Environment	Mounting on Board (Wind velocity=0m/s)
Board Material	Glass cloth epoxy plactic (Double sided)
Board Dimensions	40mm × 40mm × 1.6mm
Copper Ratio	Top side : Approx. 50% , Back side : Approx. 50%
Through-hole	—

Measurement Result ($T_{opt}=25^{\circ}C, T_{jmax}=125^{\circ}C$)

	Standard Land Pattern
Power Dissipation	633mW
Thermal Resistance	$\theta_{ja}=(125-25^{\circ}C)/0.633W=158^{\circ}C/W$

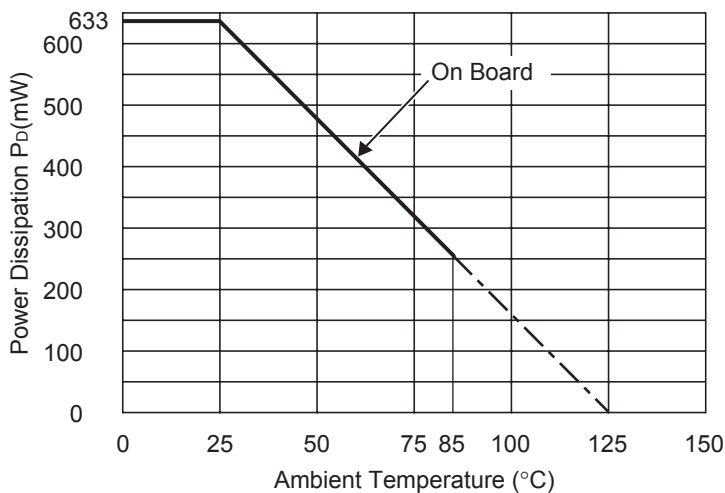

Power Dissipation

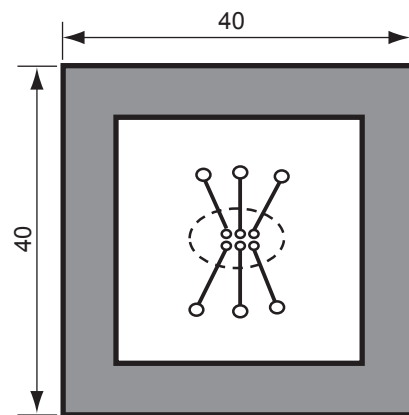

Measurement Board Pattern

○ IC Mount Area (Unit : mm)

RECOMMENDED LAND PATTERN (WLCSP)

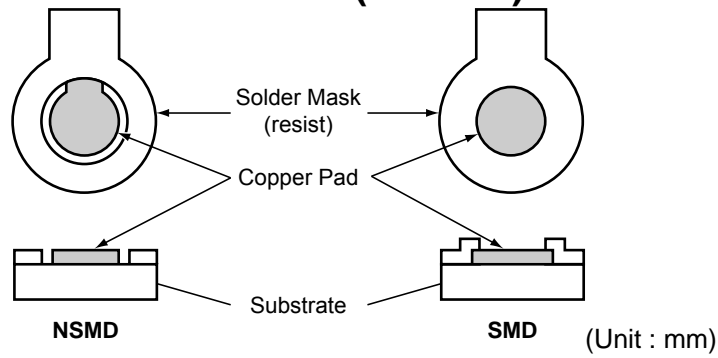

NSMD and SMD Pad Definition

Pad definition	Copper Pad	Solder Mask Opening
NSMD (Non-Solder Mask defined)	0.20mm	Min. 0.30mm
SMD (Solder Mask defined)	Min. 0.30mm	0.20mm

- * Pad layout and size can be modified by customers material, equipment, method.
- * Please adjust pad layout according to your conditions.
- * Recommended Stencil Aperture Size....ø0.3mm
- * Since lead free WL-CSP components are not compatible with the tin/lead solder process, you shall not mount lead free WL-CSP components using the tin/lead solder paste.

R5326N SERIES MARK SPECIFICATION

• SOT-23-6 (SC-74)

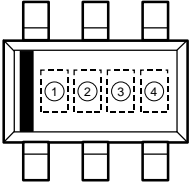

①, ② : Product Code (refer to Part Number vs. Product Code)

③, ④ : Lot Number

• Part Number vs. Product Code

Part Number	Product Code		Set V _{OUT}	
	①	②	VR1	VR2
R5326N001A	1	A	2.8V	2.8V
R5326N002A	1	B	1.8V	3.0V
R5326N003A	1	C	2.8V	3.3V
R5326N004A	1	D	1.8V	1.8V
R5326N005A	1	E	2.8V	2.6V
R5326N006A	1	F	1.2V	1.8V
R5326N007A	1	G	2.5V	1.2V
R5326N008A	1	H	1.8V	2.6V
R5326N009A	1	J	2.7V	1.8V
R5326N010A	1	K	2.8V	1.8V
R5326N011A	1	L	1.5V	2.6V
R5326N012A	1	M	1.1V	1.3V
R5326N013A	1	N	2.5V	2.8V
R5326N014A	1	P	2.9V	2.9V
R5326N015A	1	Q	2.7V	1.3V
R5326N016A	1	R	1.2V	2.8V
R5326N017A	1	S	1.1V	1.1V
R5326N018A	1	T	1.2V	1.2V
R5326N019A	1	U	1.2V	2.9V

Part Number	Product Code		Set V _{OUT}	
	①	②	VR1	VR2
R5326N001B	0	A	2.8V	2.8V
R5326N002B	0	B	1.8V	3.0V
R5326N003B	0	C	2.8V	3.3V
R5326N004B	0	D	1.8V	1.8V
R5326N005B	0	E	2.8V	2.6V
R5326N006B	0	F	1.2V	1.8V
R5326N007B	0	G	2.5V	1.2V
R5326N008B	0	H	1.8V	2.6V
R5326N009B	0	J	2.7V	1.8V
R5326N010B	0	K	2.8V	1.8V
R5326N011B	0	L	1.5V	2.6V
R5326N012B	0	M	1.1V	1.3V
R5326N013B	0	N	2.5V	2.8V
R5326N014B	0	P	2.9V	2.9V
R5326N015B	0	Q	2.7V	1.3V
R5326N016B	0	R	1.2V	2.8V
R5326N017B	0	S	1.1V	1.1V
R5326N018B	0	T	1.2V	1.2V
R5326N019B	0	U	1.2V	2.9V

R5326K SERIES MARK SPECIFICATION

● PLP1820-6

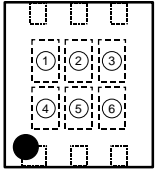

① to ④ : Product Code (refer to Part Number vs. Product Code)

⑤, ⑥ : Lot Number

● Part Number vs. Product Code

Part Number	Product Code				Set V _{out}	
	①	②	③	④	VR1	VR2
R5326K001A	V	0	0	1	2.8V	2.8V
R5326K002A	V	0	0	2	1.8V	3.0V
R5326K003A	V	0	0	3	2.8V	3.3V
R5326K004A	V	0	0	4	1.8V	1.8V
R5326K005A	V	0	0	5	2.8V	2.6V
R5326K006A	V	0	0	6	1.2V	1.8V
R5326K007A	V	0	0	7	2.5V	1.2V
R5326K008A	V	0	0	8	1.8V	2.6V
R5326K009A	V	0	0	9	2.7V	1.8V
R5326K010A	V	0	1	0	2.8V	1.8V
R5326K011A	V	0	1	1	1.5V	2.6V
R5326K012A	V	0	1	2	1.1V	1.3V
R5326K013A	V	0	1	3	2.5V	2.8V
R5326K014A	V	0	1	4	2.9V	2.9V
R5326K015A	V	0	1	5	2.7V	1.3V
R5326K016A	V	0	1	6	1.2V	2.8V
R5326K017A	V	0	1	7	1.1V	1.1V
R5326K018A	V	0	1	8	1.2V	1.2V
R5326K019A	V	0	1	9	1.2V	2.9V

Part Number	Product Code				Set V _{out}	
	①	②	③	④	VR1	VR2
R5326K001B	U	0	0	1	2.8V	2.8V
R5326K002B	U	0	0	2	1.8V	3.0V
R5326K003B	U	0	0	3	2.8V	3.3V
R5326K004B	U	0	0	4	1.8V	1.8V
R5326K005B	U	0	0	5	2.8V	2.6V
R5326K006B	U	0	0	6	1.2V	1.8V
R5326K007B	U	0	0	7	2.5V	1.2V
R5326K008B	U	0	0	8	1.8V	2.6V
R5326K009B	U	0	0	9	2.7V	1.8V
R5326K010B	U	0	1	0	2.8V	1.8V
R5326K011B	U	0	1	1	1.5V	2.6V
R5326K012B	U	0	1	2	1.1V	1.3V
R5326K013B	U	0	1	3	2.5V	2.8V
R5326K014B	U	0	1	4	2.9V	2.9V
R5326K015B	U	0	1	5	2.7V	1.3V
R5326K016B	U	0	1	6	1.2V	2.8V
R5326K017B	U	0	1	7	1.1V	1.1V
R5326K018B	U	0	1	8	1.2V	1.2V
R5326K019B	U	0	1	9	1.2V	2.9V

R5326Z SERIES MARK SPECIFICATION

• WLCSP-6-P1

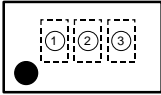

- ① : H (Fixed)
- ②, ③ : Lot Number

• Product Code vs. Marking

(A part number is discriminable from a product code and a lot number)

Part Number	Product Code	Set V _{OUT}		Part Number	Product Code	Set V _{OUT}	
	①	VR1	VR2		①	VR1	VR2
R5326Z001A	H	2.8V	2.8V	R5326Z001B	H	2.8V	2.8V
R5326Z002A	H	1.8V	3.0V	R5326Z002B	H	1.8V	3.0V
R5326Z003A	H	2.8V	3.3V	R5326Z003B	H	2.8V	3.3V
R5326Z004A	H	1.8V	1.8V	R5326Z004B	H	1.8V	1.8V
R5326Z005A	H	2.8V	2.6V	R5326Z005B	H	2.8V	2.6V
R5326Z006A	H	1.2V	1.8V	R5326Z006B	H	1.2V	1.8V
R5326Z007A	H	2.5V	1.2V	R5326Z007B	H	2.5V	1.2V
R5326Z008A	H	1.8V	2.6V	R5326Z008B	H	1.8V	2.6V
R5326Z009A	H	2.7V	1.8V	R5326Z009B	H	2.7V	1.8V
R5326Z010A	H	2.8V	1.8V	R5326Z010B	H	2.8V	1.8V
R5326Z011A	H	1.5V	2.6V	R5326Z011B	H	1.5V	2.6V
R5326Z012A	H	1.1V	1.3V	R5326Z012B	H	1.1V	1.3V
R5326Z013A	H	2.5V	2.8V	R5326Z013B	H	2.5V	2.8V
R5326Z014A	H	2.9V	2.9V	R5326Z014B	H	2.9V	2.9V
R5326Z015A	H	2.7V	1.3V	R5326Z015B	H	2.7V	1.3V
R5326Z016A	H	1.2V	2.8V	R5326Z016B	H	1.2V	2.8V
R5326Z017A	H	1.1V	1.1V	R5326Z017B	H	1.1V	1.1V
R5326Z018A	H	1.2V	1.2V	R5326Z018B	H	1.2V	1.2V
R5326Z019A	H	1.2V	2.9V	R5326Z019B	H	1.2V	2.9V