

Metal Film Fuse Resistors

Type: **ERQN**

(Metal film resistors
Low power fusible type)



■ Features

- Fuse within 60 seconds at 1.25 W
- No increase of electric current or arcing at fusion
- Covered with shrink tube
- Very low surface temperature at overload
- Low resistance values on request
- Approved under the ISO 9001 system

■ Explanation of Part Numbers

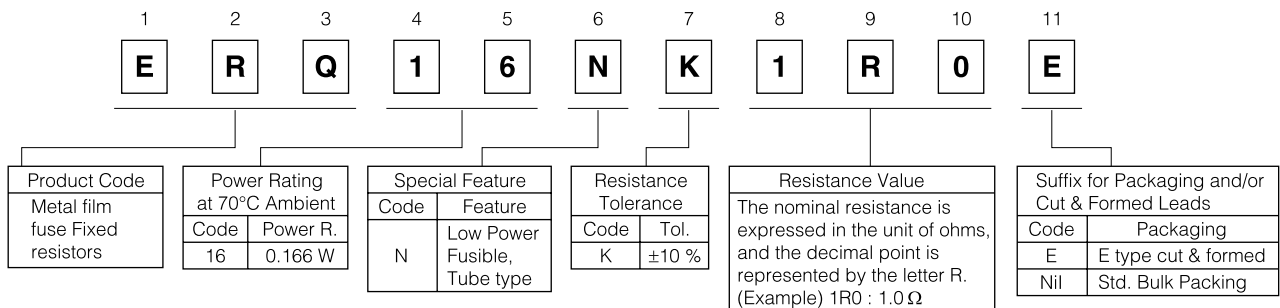

The above example shows a standard metal film fuse resistor, 0.166 W power rating, resistance value of 1.0Ω tolerance of 10 %, and package of E type cut & formed.

■ Construction

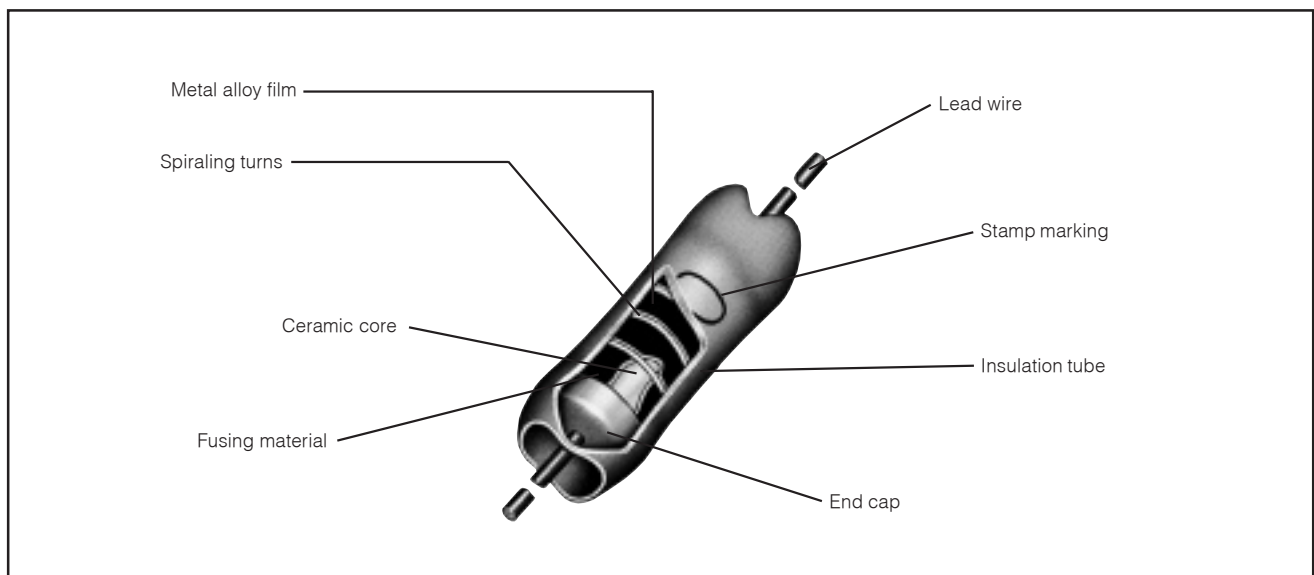

■ Ratings

Type	Power Rating at 70 °C (W)	Maximum Overload Voltage	Dielectric Withstanding Voltage (VAC)	Resistance Tolerance (%)	Resistance Range (Ω)		T.C.R. ×10 ⁻⁶ /°C (ppm/°C)	Standard Resistance Values	Marking Method on Body	Weight (g/pcs.)
					min.	max.				
ERQ16N	0.166	2.5 times of rated voltage ⁽¹⁾	350	K (±10)	0.1	2.2	3200±500	E12	Stamp	0.26

(1) Rated Continuous Working Voltage (RCWV)=√ Power Rating (W) × Resistance Value (Ω)

Maximum Open Circuit Voltage

Refers to the maximum value of the voltage applied between terminals of the resistor when the resistor is opened in an electric circuit, 10 kW (Zero to peak).

$$E_p = \sqrt{10000 \times R}$$

E_p : Maximum Open Circuit Voltage (V)

R: Resistance Value (Ω)

Power Derating Curve

For resistors operated in ambient temperatures above 70 °C, power rating should be derated in accordance with the figure to the right.

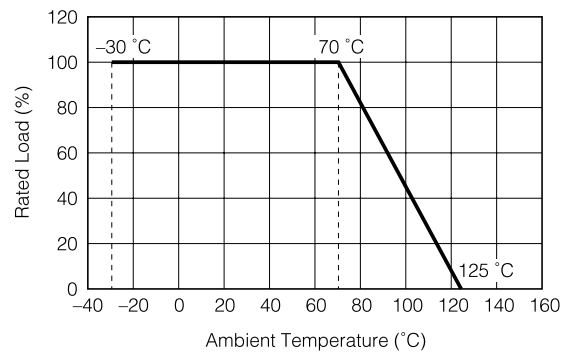

■ Explanation of Marking

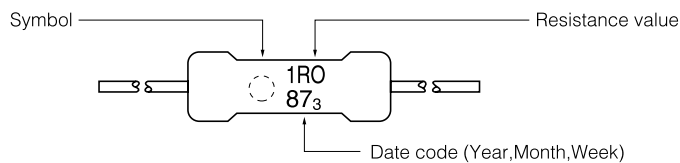

■ Dimensions in mm (not to scale)

● Bulk type

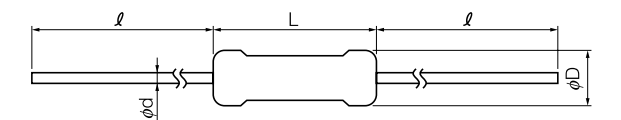

Type	L	φD	l	φd
ERQ16N	7.0±1.5	2.3±1.0	30.0±3.0	0.65±0.05

● Cut & Formed type (Type E)

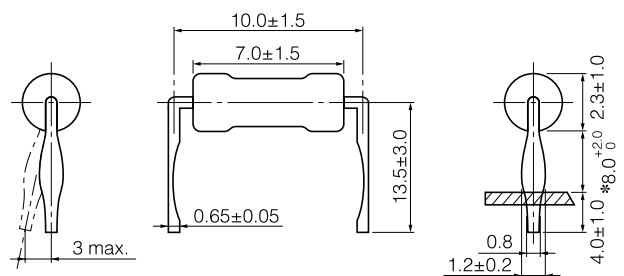

* Dimension: The height from the upper surface of PCB when inserting a resistor's lead wire in the 0.8 mm hole.

Performance Specifications

Characteristics	Specifications	Test Methods
Incombustibility	The flame should be extinguished within 10 seconds after the resistors taken out of the test flame.	The resistor is exposed to specified test flame for 15 seconds, and is taken out for 15 seconds. This cycle is conducted 5 times.
Fusing Characteristics	Open within 60 seconds at 1.25 W. (Constant current circuit)	

Typical Performance Data

1. Example of Fusing Characteristics (Reference)

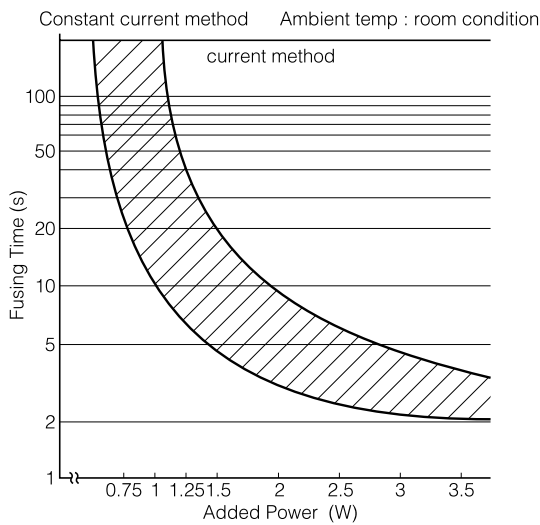

2. Hot Spot Temperature (Reference)

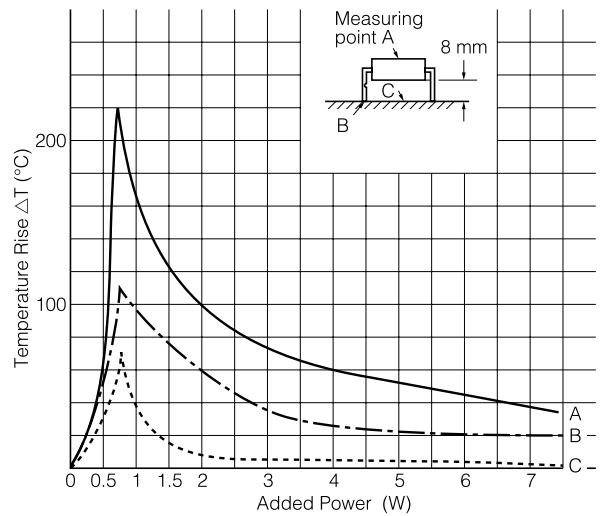

⚠ Safety Precautions

These are fixed metal film resistors, low power fusible type, and are different from ordinary fixed resistors. Special precautions are required as instructed below. Conditions of use should be mutually confirmed by both parties and denoted in the Individual Specifications for approval.

1. Confirmation of fusing condition

The fusing characteristics of this resistor differs between a constant current circuit and a constant voltage circuit, and should be carefully confirmed in an actual circuit before actual use.

2. Consideration for waveform pulse voltage, inrush voltage, transient voltage.

In the case of inrush voltage circuit, transient phenomenon for such application of a considerably high voltage in a short time, or application of waveform pulse voltage with high peak voltage, sufficient consideration should be given depending on the actual application circuit.

3. Conditions of use in steady state

Unless used in the load range within the power derating curve, a premature breakage (opening of circuit although it is not abnormal) may occur. Consider using them within the sufficient allowance under the power derating curve.

4. Mounting by soldering

1) When mounting on a printed circuit board by soldering, make sure the soldering temperature and time applied to the lead wires are within specifications.

Particular care should be taken when preheating process is done before dipping in solder bath. Soldering conditions are specified as follows.

(Type E cut & formed)

- Preheat Not higher than 100 °C, within 60 seconds.
- Solder dip Not higher than 260 °C, within 4 seconds.

(For details, test and review for every possible cases)

2) When using a soldering iron, release heat by using pliers or the like as shown in Fig. 1 to minimize the heat effect to the resistance element. If soldered for a long time at high temperature the performance may be deteriorated by heat, or the resistor may open. So, keep a safe distance over 6 mm from the body and solder within 3 seconds at 300 °C or lower temperature.

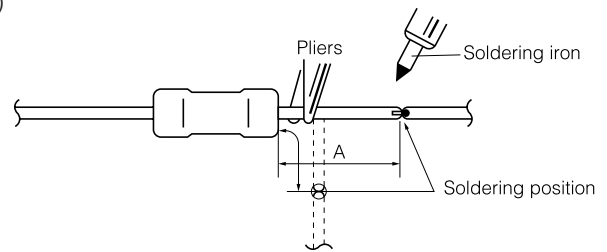

Fig.1

5. Precautions

The products in this catalog are intended for use in general standard applications for general electronic equipment (AV products, household electric appliances, office equipment, information and communication equipment, etc.); Accordingly, the use in the following special environments, and such environmental conditions may affect the performance of the products; Do not use in the following environmental conditions.

- ① In liquids such as water, oil, chemical, and organic solvent.
- ② Under direct sunlight, outdoor and dusty atmospheres.
- ③ In places full of corrosive gases such as salt water, Cl₂, H₂S, NH₃, SO₂, and NO₂.
- ④ In environments with high static electricity and strong electromagnetic waves.
- ⑤ Close to a heating component, and where a flammable such as a polyvinyl chloride wire is arranged close to the product.
- ⑥ If sealed and coated with resin, etc.
- ⑦ When water or a water-soluble detergent is used in cleaning free soldering and in flux cleaning after soldering. (Pay particular attention to soluble flux.)

6. Cleaning

This resistor is not solvent resistant, and where the manufacturing process includes a cleaning step using organic solvent or the like, arrange the process so as to mount the resistor after cleaning.

7. Handling of resistor

- 1) Do not apply more tension than necessary on the lead wire, in particular, the joint of terminal. When bending a lead wire, be careful not to apply force to the resistance element, and bend in a natural curvature.
- 2) Be careful so that the surface coating tube of the resistor is not damaged by sharp edge of knife or the like.

8. Mounting position of resistor

Arrange so that vinyl-coated wire does not contact the resistor. Select the mounting position carefully if there is any heat source in the peripheral parts.

9. Long-term storage

When storing the resistors for a long period, avoid damp, dusty or hot place, and harmful atmospheres (hydrogen chloride, sulfurous acid, etc.)

(Data for Reference)

■ Pulse Characteristics (Normal)

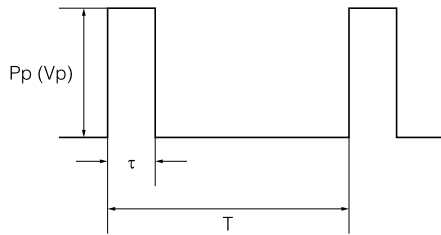

- P_p : Pulse limit power (W)
- V_p : Pulse limit voltage (V)
- τ : Pulse continuous time (s)
- T : Period (s)
- V_R : Rated voltage (V)
- P : Rated power (W)
- R : Resistance Value (Ω)

Withstand pulse limit power is calculated by the next method.

$$P_p = K \cdot P \cdot T/\tau$$

$$V_p = \sqrt{K \cdot P \cdot R \cdot T/\tau}$$

$$I_p = \sqrt{K \cdot P \cdot 1/R \cdot T/\tau}$$

- $T > 1(s) \rightarrow T = 1(s)$
- $T/\tau > 100 \rightarrow T/\tau = 100$
- $P_p < P \rightarrow P$ stands for P_p
($V_p < V_R \rightarrow V_R$ stands for V_p)
- P_p or V_p is reference value
Conditions : Pulse added time=1000 h
Resistance change= $\pm 5\%$
Room temperature

Type	K
ERQ16N	0.2

■ Pulse Characteristics (Inrush)

(Test Methods)

Resistance change $\leq \pm 5\%$ with pulse 10000 cycles as in the figure.

- 1) Added power and added voltage are within the graph shown below.
- 2) Added in normal temperature and humidity

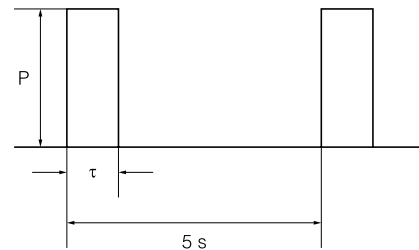

(Closely Resemble Methods)

Peak voltage put together as shown in the figure.

