

### VIPower: Offline constant current LED driver using VIPer12/22A

#### Introduction

High brightness LEDs are becoming a prominent source of light and often have better efficiency and reliability when compared to that of conventional light sources. While LEDs can operate from an energy source as simple as a battery and resistor, most applications require an efficient energy source not only for the reduction of losses, but also for the lumen maintenance of the LED itself. Using integrated off line switching regulators like the VIPer12A and VIPer22A in a constant current configuration, a low cost, high efficient LED driver for multiple LEDs has been developed.

This document introduces the isolated and non-isolated offline constant current LED driver based on the VIPerX2A family. All three LED driver configurations operate in the extended wide range input voltage, from 90 to 264Vac.

VIPer12A and VIPer22A are low cost monolithic smart power devices with integrated PWM controllers. Their internal control circuit offers benefits such as automatic burst mode in low load condition, overvoltage protection in hiccup mode, and large voltage range on the VDD pin. An isolated VIPer12A constant current LED driver has been configured to drive 1 to 4 LEDs while the isolated VIPer22A configuration has been optimized for 2 to 8 LEDs.

#### VIPer12A constant current LED driver board layout

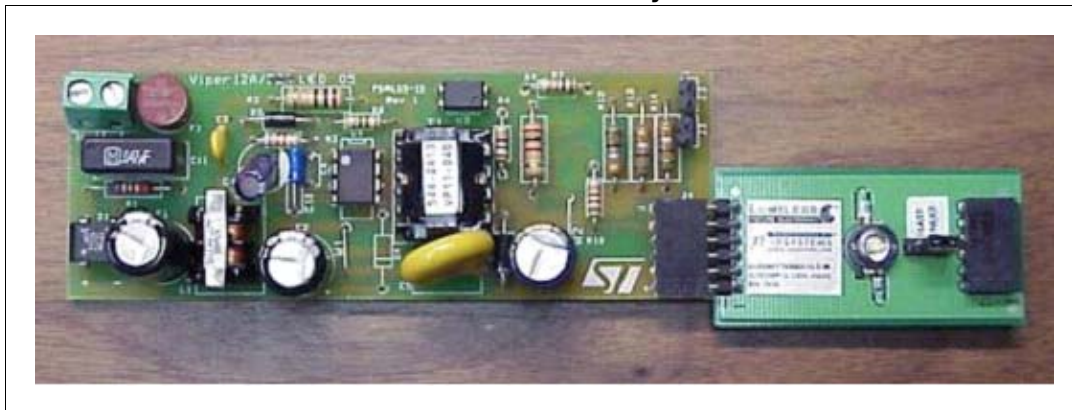

# Contents

<b>1</b>	<b>LED parameters</b> .....	<b>6</b>
<b>2</b>	<b>LED Intensity</b> .....	<b>7</b>
<b>3</b>	<b>Design consideration</b> .....	<b>8</b>
<b>4</b>	<b>Board description</b> .....	<b>11</b>
<b>5</b>	<b>Transformer specifications</b> .....	<b>12</b>
<b>6</b>	<b>Current selectable reference board</b> .....	<b>13</b>
<b>7</b>	<b>PCB layout</b> .....	<b>29</b>
<b>8</b>	<b>General circuit description</b> .....	<b>30</b>
<b>9</b>	<b>Waveforms</b> .....	<b>31</b>
<b>10</b>	<b>EMI results</b> .....	<b>32</b>
<b>11</b>	<b>Current regulation</b> .....	<b>33</b>
<b>12</b>	<b>Ripple current</b> .....	<b>34</b>
<b>13</b>	<b>1.8" Round LED board configuration</b> .....	<b>35</b>
<b>14</b>	<b>Round LED board layout</b> .....	<b>36</b>
<b>15</b>	<b>EMI result</b> .....	<b>37</b>
<b>16</b>	<b>Current regulation</b> .....	<b>38</b>
<b>17</b>	<b>Ripple current</b> .....	<b>39</b>
<b>18</b>	<b>Low cost option</b> .....	<b>40</b>

---

19	PCB layout .....	42
20	Conclusion .....	43
21	Revision history .....	44

## List of figures

Figure 1.	Current vs. LUX and VF . . . . .	8
Figure 2.	Mechanical characteristics of the transformer . . . . .	12
Figure 3.	VIPer12A current selectable LED driver schematic . . . . .	13
Figure 4.	VIPer22A current selectable LED driver schematic . . . . .	15
Figure 5.	VIPer12A constant current (350mA) LED driver schematic . . . . .	17
Figure 6.	VIPer22A constant current (350mA) LED driver schematic . . . . .	19
Figure 7.	VIPer12A constant current (700mA) LED driver schematic . . . . .	21
Figure 8.	VIPer22A constant current (700mA) LED driver schematic . . . . .	23
Figure 9.	VIPer12A constant current (1.05A) LED driver schematic . . . . .	25
Figure 10.	VIPer22A constant current (1.05A) LED driver schematic . . . . .	27
Figure 11.	Board top side (not in scale) . . . . .	29
Figure 12.	Board bottom side viewed from top side (not in scale) . . . . .	29
Figure 13.	VIPer12A with 1 LED at output . . . . .	31
Figure 14.	VIPer12A with 4 LEDs at output . . . . .	31
Figure 15.	VIPer22A with 2 LEDs at output . . . . .	31
Figure 16.	VIPer22A with 8 LEDs at output . . . . .	31
Figure 17.	VIPer12A EMI . . . . .	32
Figure 18.	VIPer22A EMI . . . . .	32
Figure 19.	VIPer12A current regulation . . . . .	33
Figure 20.	VIPer22A current regulation . . . . .	33
Figure 21.	Ripple at 264Vac (VIPer12A) . . . . .	34
Figure 22.	Ripple at 264Vac (VIPer22A) . . . . .	34
Figure 23.	Top Side of Board (not in scale) . . . . .	36
Figure 24.	Bottom Side of Board (not in scale) . . . . .	36
Figure 25.	Top board layout . . . . .	36
Figure 26.	Bottom board layout . . . . .	36
Figure 27.	VIPer22A round LED EMI . . . . .	37
Figure 28.	VIPer12A round LED EMI . . . . .	37
Figure 29.	VIPer22A round LED board current regulation . . . . .	38
Figure 30.	VIPer12A round LED board current regulation . . . . .	38
Figure 31.	Ripple Current at 264Vac input (VIPer22A) . . . . .	39
Figure 32.	Ripple Current at 264Vac input (VIPer12A) . . . . .	39
Figure 33.	Non-isolated buck configuration schematic . . . . .	40
Figure 34.	VIPer22A buck board layout . . . . .	42

## List of tables

Table 1.	Electrical characteristics at 350mA, junction temperature, $T_J = 25\text{ }^\circ\text{C}$ . . . . .	6
Table 2.	Flux characteristics at 350mA, junction temperature, $T_J = 25\text{ }^\circ\text{C}$ . . . . .	7
Table 3.	1 to 4 LEDs system at 350mA . . . . .	9
Table 4.	2 to 8 LEDs system at 350mA . . . . .	9
Table 5.	VIPer12A LED system at 700mA . . . . .	10
Table 6.	VIPer12A LED system at 1.05A . . . . .	10
Table 7.	VIPer22A LED system at 700mA . . . . .	10
Table 8.	VIPer22A LED system at 1.05A . . . . .	10
Table 9.	Number of LEDs that can be driven . . . . .	11
Table 10.	Bill of materials . . . . .	14
Table 11.	Bill of materials . . . . .	16
Table 12.	Bill of material . . . . .	18
Table 13.	Bill of materials . . . . .	20
Table 14.	BOM change for VIPer22A 350mA solution . . . . .	21
Table 15.	Bill of materials . . . . .	22
Table 16.	Bill of materials . . . . .	24
Table 17.	Bill of materials . . . . .	26
Table 18.	Bill of materials . . . . .	28
Table 19.	Bill of materials . . . . .	40
Table 20.	Document revision history . . . . .	44

# 1 LED parameters

LED voltage drop tolerance varies by +/- 16.6% for the white LED, as shown in [Table 1](#). Different colors will have different typical voltage drop. For this reason, it is recommended that the LEDs be connected in series rather than parallel. If the LEDs were connected in parallel, the current flowing in each LED would depend on each unit's individual voltage drop ( $V_F$ ) characteristic and not be matched to the other devices, resulting in different brightness for each LED. Below is the forward voltage drop spec from the Luxeon Star Technical Data Sheet DS23

**Table 1. Electrical characteristics at 350mA, junction temperature,  $T_J = 25\text{ }^\circ\text{C}$**

Color	Forward Voltage $V_F$ (V)			Dynamic Resistance ( $\Omega$ ) $R_D$	Temperature Coefficient of Forward Voltage (mV/ $^\circ\text{C}$ ) $\Delta V_F/\Delta T_J$
	Min	Typ.	Max		
White	2.79	3.42	3.99	1.0	-2.0
Green	2.79	3.42	3.99	1.0	-2.0
Cyan	2.79	3.42	3.99	1.0	-2.0
Blue	2.79	3.42	3.99	1.0	-2.0
Royal Blue	2.79	3.42	3.99	1.0	-2.0
Red	2.31	2.85	3.27	2.4	-2.0
Amber	2.31	2.85	3.27	2.4	-2.0

## 2 LED Intensity

The intensity of the brightness also varies with different color as shown in the Luxeon data sheet.

**Table 2. Flux characteristics at 350mA, junction temperature,  $T_J = 25\text{ }^\circ\text{C}$**

Color	Minimum Luminous Flux (lm) or Radiometric Power (MW) $\phi_V$	Typical Luminous Flux (lm) Or Radiometric Power (MW) $\phi_V$
White	13.9	25
Green	13.9	30
Cyan	13.9	30
Blue	3.8	10
Royal Blue	55MW	150MW
Red	13.9	27
Amber	10.7	25

The brightness is directly related to the current driving the LED. A test was conducted in a closed box with a white LED mounted 12 inches away from the light meter. The results showed a linear relationship between current and light output as shown in [Figure 1](#).

[Figure 1](#). also shows the relation between current and forward drop of the LED.

### 3 Design consideration

The main consideration in designing this constant current power supply is the transformer. Since one to four LEDs can be operated, and each LED is 3.5V nominal, the output can vary from 3.5V to 14V. The output voltage will be reflected back across the transformer and will in turn change the V<sub>dd</sub> voltage to the control circuit and the peak V<sub>ds</sub> voltage across the MOSFET. The transformer must be designed with three limiting factors in mind.

- V<sub>dd</sub>, which has a range of 9V for under voltage to 38V for the over voltage threshold.
- Wattage, specified at 8W for the VIPer12A and 12W for the VIPer22A
- Reflected voltage across the drain of the MOSFET which is the turn ratio of  $(N_p \div N_s) \times V_{out}$ , added to the input voltage and must be below 730V.

Figure 1. Current vs. LUX and V<sub>F</sub>

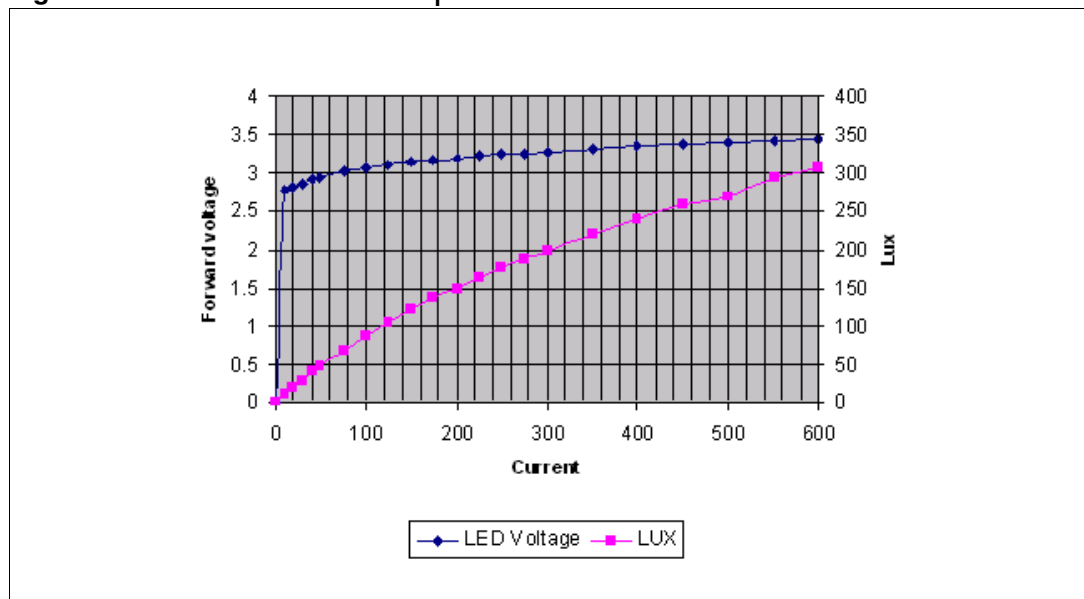

In order to keep the reflected voltage manageable, the transformer is designed for a turn's ratio of primary to secondary output voltage for the maximum number of LEDs. Using this criteria, as the number of LEDs is reduced, so is the reflected voltage. If the transformer were based on one LED then the reflected voltage would quadruple with four LEDs and may exceed the rating of the VIPer. The turn's ratio between secondary to the V<sub>dd</sub> winding is set for an output voltage of one LED to the minimum V<sub>dd</sub> voltage, of 9V. As more LEDs are added, the V<sub>dd</sub> voltage increases proportionally until it reaches the overvoltage shutdown point of 42V nominal. With this starting point a table can be derived as shown in [Table 3](#). for the VIPer12 and [Table 4](#). for VIPer22A. The highlighted values indicate parameters that are approaching the limit for that parameter. The following table shows the results of the parameters that should be considered for the proper design.



**Table 3. 1 to 4 LEDs system at 350mA**

# of LEDs	Output voltage at 350mA [1]	Vdd	Output Wattage	V reflected	Vds not including spike at 375Vdc	Turns ratio Ns/Np
1	3.57	10.05	1.25	30.51282	405.5128	0.117
2	6.99	18.33	2.45	59.74359	434.7436	Nvdd/Ns
3	10.41	26.60	3.64	88.97436	463.9744	2.419
4	13.83	34.87	4.85	118.2051	493.2051	
5	17.25	43.15	6.04	147.4359	522.4359	

- 1 The output voltage includes 0.175V drop in the current sense resistor.

In the case of [Table 3.](#), the Vdd would be the limiting factor reaching the over voltage shut down point. In the case of [Table 4.](#), the Vdd would be the limiting factor reaching the overvoltage shutdown point. The turn ratio of primary to secondary is based on the highest output voltage for 8 LEDs. The VIPer12A and VIPer22A are ideal for this application because of the wide range of Vdd. This ranges from 8 to 42V typical. The overvoltage kicks in at 42V, preventing the addition of LEDs driving the output voltage, the voltage across the drain to source and the wattage, from being exceeded.

**Table 4. 2 to 8 LEDs system at 350mA**

# of LEDs	Output voltage at 350mA [2]	Vdd	Output Wattage	V reflected	Vds not including spike at 375Vdc	Turns ratio
2	6.99	10.63	2.45	33.12796	408.128	0.211
3	10.41	15.67	3.64	49.33649	424.3365	Nvdd/Ns
4	13.83	20.71	4.84	65.54502	440.545	1.474
5	17.25	25.75	6.04	81.75355	456.7536	
6	20.67	30.79	7.23	97.96209	472.9621	
7	24.09	35.84	8.43	114.1706	489.1706	
8	27.51	40.88	9.63	130.3791	505.3791	
9	30.93	45.92	10.83	146.5877	521.5877	

- 2 The output voltage includes 0.175V drop in the current sense resistor.

The circuit shown in [Figure 5.](#) can drive from 1 to 4 LEDs. The circuit shown in [Figure 6.](#) can drive from 2 to 8 LEDs. [Table 3.](#) and [Table 4.](#) are based on the nominal voltage drop for a white LED as stated in the LED datasheet shown earlier. The actual number of LEDs that can be driven depends on the VF spread of the type of LEDs used and the Vdd range (9V to 38V) when worse case conditions are taken into account. Worse case parameters must be considered for a robust design. If the design calls for a fixed number of LEDs, then the only limiting factor is the VIPer's maximum output power capability.

[Table 5.](#) to [Table 8.](#) will show the same measurements taken with 700mA and 1.05A at the output for VIPer12A and VIPer22A circuit configurations. Here, the limiting factor is the maximum output power that can be attained from VIPer12A and VIPer22A with 6W maximum and 10W maximum output power respectively.

**Table 5. VIPer12A LED system at 700mA**

# of LEDs	Output voltage at 700mA	Vdd	Output Wattage	V reflected	Vds not including spike at 375Vdc	Turns ratio Ns/Np
1	3.67	13.22	2.61	30.51282	433	0.117
2	7.15	23.42	5.10	59.74359	464	

**Table 6. VIPer12A LED system at 1.05A**

# of LEDs	Output voltage at 1050mA	Vdd	Output Wattage	V reflected	Vds not including spike at 375Vdc	Turns ratio Ns/Np
1	3.42	13.49	3.49	30.51282	430	0.117

**Table 7. VIPer22A LED system at 700mA**

# of LEDs	Output voltage at 700mA	Vdd	Output Wattage	V reflected	Vds not including spike at 375Vdc	Turns ratio
2	7.18	11.75	5.026	33.12796	433	0.211
3	10.48	16.72	7.336	49.33649	447	
4	13.48	21.2	9.436	65.54502	461	

**Table 8. VIPer22A LED system at 1.05A**

# of LEDs	Output voltage at 1050mA	Vdd	Output Wattage	V reflected	Vds not including spike at 375Vdc	Turns ratio
2	6.62	11.5	6.951	33.12796	433	0.211

## 4 Board description

This demonstration board is a redesign of earlier versions of the VIPer12A and VIPer22A LED driver reference designs. The board has been configured to allow the user to select the output current of 350mA, 700mA or 1.05A by using the jumpers, J2 and J4, on the board without having to change any components on the evaluation board. [Table 9](#), below outlines the range of LEDs that can be driven depending on the version of board and type of LEDs selected:

**Table 9. Number of LEDs that can be driven**

Board Version	1W LED (I <sub>out</sub> = 350mA)		3W LED (I <sub>out</sub> = 700mA)		5W LED (I <sub>out</sub> = 1.05A)	
VIPer12A	Min 1	Max 4	Min 1	Max 2	Min 1	Max 1
VIPer22A	Min 2	Max 8	Min 2	Max 4	Min 2	Max 2

On the evaluation board, the value of the sense resistor is selected by jumpers J2 and J3. When both J2 and J3 are open, the sense resistor is set to 0.5Ω making the output current 0.35mA. When either J2 or J3 is shorted, the output sense resistor is fixed to 0.25Ω making the output current 700mA. With both J2 and J3 shorted, the output current will be set to 1.05A.

## 5 Transformer specifications

The transformer is designed and manufactured by Cramer Coil and Transformer Co. The electrical characteristics of the transformer are as follows:

- Primary Inductance: 3.25mH +/-10%
- Primary Leakage Inductance: 39.9µH typical
- HIPOT (N1, N3, N4 to N2): 4000VAC, 1Sec
- Turns Ratio (N1/N4:N2): 1:0.117
- Turns Ratio (N1/N4:N3): 1:0.283

When the VIPerx2A (U4) is on, energy is stored in the primary winding of transformer (8-10), T1. This energy is transferred to the auxiliary winding (5-6), and to the output (1-2) when the VIPerx2A turns off. The auxiliary winding provides the bias voltage for the VIPerx2A at pin 4 ( $V_{dd}$ ).

**Figure 2. Mechanical characteristics of the transformer**

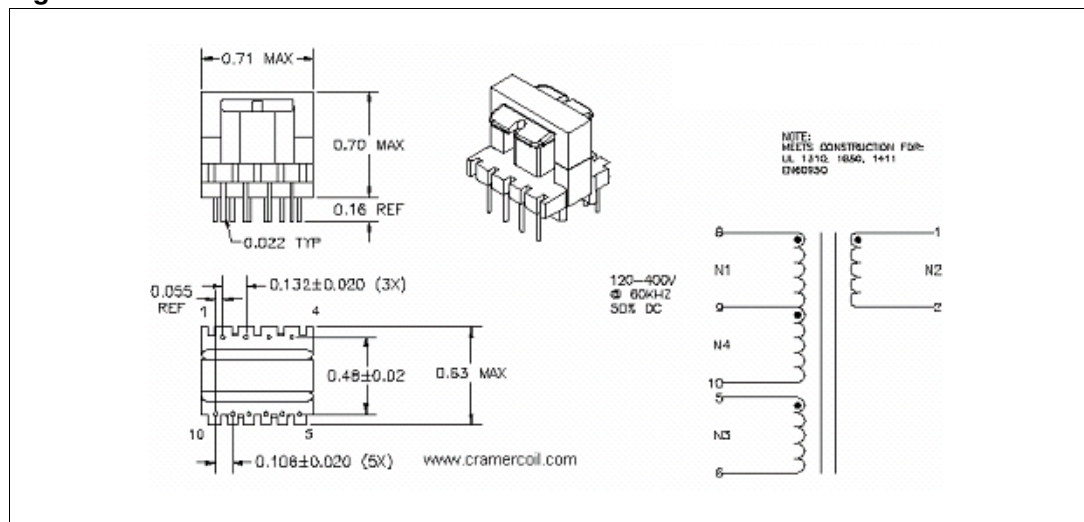

An alternate source for the transformer is Midcom, Inc. The part number for the transformer on the VIPer12A LED and VIPer22A LED board are 31929 and 31928 respectively. Further information and samples could be obtained from <http://www.midcom-inc.com>.

## 6 Current selectable reference board

The evaluation board is designed to display the full functionality of VIPer12A and VIPer22A as LED drivers to drive 1W, 3W as well as 5W LEDs at wide range input voltage. The components selected are optimized for 5W LED driver application. The following pages contain the schematics and bills of materials that reflect the components used on the boards. Based on this circuit, there are six different configurations with different output power level that could be derived by making minor components changes to the evaluation board. The subsequent pages will show the schematics and bills of materials for the circuit to drive 1W, 3W and 5W LEDs.

**Figure 3. VIPer12A current selectable LED driver schematic**

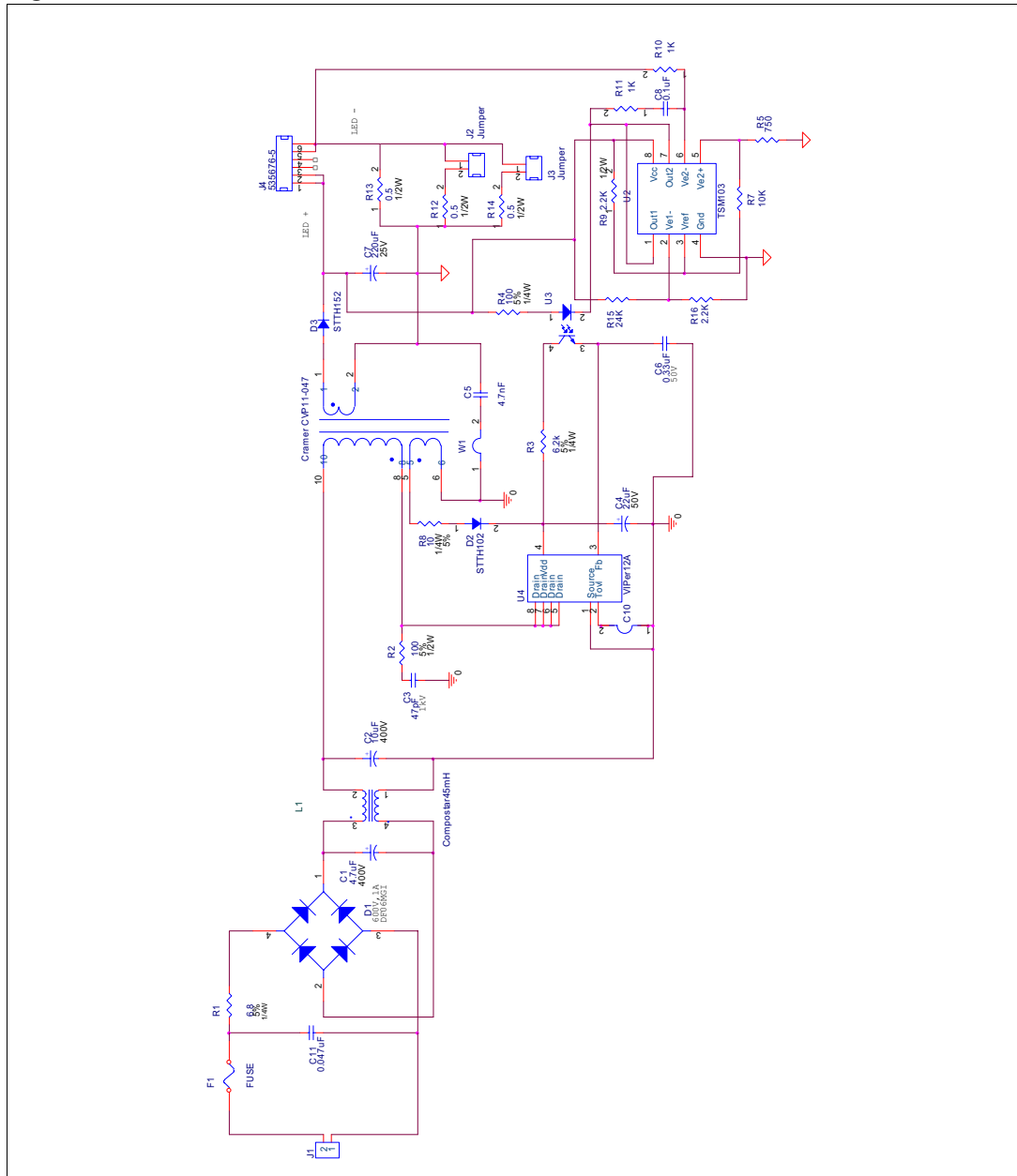

Table 10. Bill of materials

Qty	Reference	Part Description	Mfg P/N	Mfg	Geometry	Mounting
1	C1	4.7uF 400V Electrolytic	TKR2GM4R7D	Compostar	Radial	TH
1	C2	10uF 400V Electrolytic	TKR2GM100D	Compostar	Radial	TH
1	C3	47pF 1kV Ceramic	ECC-D3A470JGE	Panasonic		TH
1	C4	22uF 50V Electrolytic	EEU-FC1H220	Panasonic	Radial	TH
1	C5	4.7nF 250V Ceramic	ECK-DNA472ME	Panasonic		TH
1	C6	0.33uF 50V Ceramic	ECU-S1H334KBB	Panasonic		TH
1	C7	220uF 25V Electrolytic	EEU-FC1E221	Panasonic	Radial	TH
1	C8	0.1uF 50V Ceramic			1206	SMD
1	C10	22Ga solid bus wire			Axial	TH
1	C11	0.047uF 250V boxcap	ECQ-U2A473MG	Panasonic	Radial	TH
1	D1	DIPBridge 600V 1A	DB105	Micro Commercial		TH
1	D2	STTH102 diode	STTH102	STMicroelectronics	Axial DO-41	TH
1	D3	STTH152 diode	STTH152	STMicroelectronics	Axial DO-15	TH
1	F1	Fuse TR5 0.5A	3720500041	Wickman	Radial	TH
1	J1	Phoenix 2 Pin Connector	MKDSN1.5/2	Phoenix Contact		TH
2	J2, J3	Current Select Jumper	22-28-8020	Molex		TH
1	J4	Stackable Receptacle	535676-5	Tyco	6 Pin	TH
1	L1	45mH common mode choke	FUU10S-V24503-Q22650	Compostar		TH
1	R1	6.8Ω 5% 1/4W	Carbon Composition		Axial	TH
1	R2	100Ω 5% 0.5W			Axial	TH
1	R3	6.2Ω 5% 0.25W			Axial	TH
1	R4	100Ω 5% 0.25W			Axial	TH
1	R5	750Ω 5% 0.25W			1206	SMD
1	R7	10kΩ 5% 0.25W			Axial	TH
1	R8	10Ω 5% 0.25W			Axial	TH
1	R9	2.2kΩ 5% 0.5W			Axial	TH
1	R10	1kΩ 5% 0.25W			Axial	TH
1	R11	1kΩ 5% 0.25W			1206	SMD
3	R12, R13, R14	0.5Ω 5% 0.5W			Axial	TH
1	R15	24kΩ 5% 0.25W			1206	SMD
1	R16	2.2kΩ 5% 0.25W			1206	SMD
1	T1	Cramer Transformer	CVP11-047	Cramer Coil		TH



Table 11. Bill of materials

Qty	Reference	Part Description	Mfg P/N	Mfg	Geometry	Mounting
2	C1, C2	10uF 400V Electrolytic	TKR2GM100D	Compostar	Radial	TH
1	C3	47pF 1kV Ceramic	ECC-D3A470JGE	Panasonic		TH
1	C4	22uF 50V Electrolytic	EEU-FC1H220	Panasonic	Radial	TH
1	C5	4.7nF 250V Ceramic	ECK-DNA472ME	Panasonic		TH
1	C6	0.33uF 50V Ceramic	ECU-S1H334KBB	Panasonic		TH
1	C7	220uF 50V Electrolytic	EEU-FC1H221	Panasonic	Radial	TH
1	C8	0.1uF 50V Ceramic			1206	SMD
1	C10	22Ga solid bus wire			Axial	TH
1	C11	0.047uF 250V boxcap	ECQ-U2A473MG	Panasonic	Radial	TH
1	D1	DIPBridge 600V 1A	DB105	Micro Commercial		TH
1	D2	STTH102 diode	STTH102	STMicroelectronics	Axial DO-41	TH
1	D3	STTH152 diode	STTH152	STMicroelectronics	Axial DO-15	TH
1	D4	Peak Clamp	PKC136	STMicroelectronics	Axial DO-15	TH
1	F1	Fuse TR5 0.5A	3720500041	Wickman	Radial	TH
1	J1	Phoenix 2 Pin Connector	MKDSN1.5/2	Phoenix Contact		TH
2	J2, J3	Current Select Jumper	22-28-8020	Molex		TH
1	J4	Stackable Receptacle	535676-5	Tyco	6 Pin	TH
1	L1	45mH common mode choke	FUU10S-V24503-Q22650	Compostar		TH
1	R1	5Ω 5% 1W wire wound			Axial	TH
1	R2	100Ω 5% 0.5W			Axial	TH
1	R3	6.2kΩ 5% 0.25W			Axial	TH
1	R4	100Ω 5% 0.25W			Axial	TH
1	R5	750Ω 5% 0.25W			1206	SMD
1	R7	10kΩ 5% 0.25W			Axial	TH
1	R8	51Ω 5% 0.25W			Axial	TH
1	R9	2.2kΩ 5% 0.5W			Axial	TH
1	R10	1kΩ 5% 0.25W			Axial	TH
1	R11	1kΩ 5% 0.25W			1206	SMD
3	R12, R13, R14	0.5Ω 5% 0.5W			Axial	TH
1	R15	24kΩ 5% 0.25W			1206	SMD
1	R16	2.2kΩ 5% 0.25W			1206	SMD
1	T1	Cramer Transformer	CVP11-046	Cramer Coil		TH
1	U2	VIPer22A	VIPer22ADIP	STMicroelectronics	8 Pin DIP	TH



Table 11. Bill of materials

Qty	Reference	Part Description	Mfg P/N	Mfg	Geometry	Mounting
1	U3	Dual OpAmp & Voltage Ref.	TSM103ID	STMicroelectronics	SO8	SMD
1	U4	Optocoupler	H11A817A/LTV817A	Fairchild/LiteOn	4 Pin DIP	TH
1	W1	22 Ga solid bus wire			Axial	TH

Figure 5. VIPer12A constant current (350mA) LED driver schematic

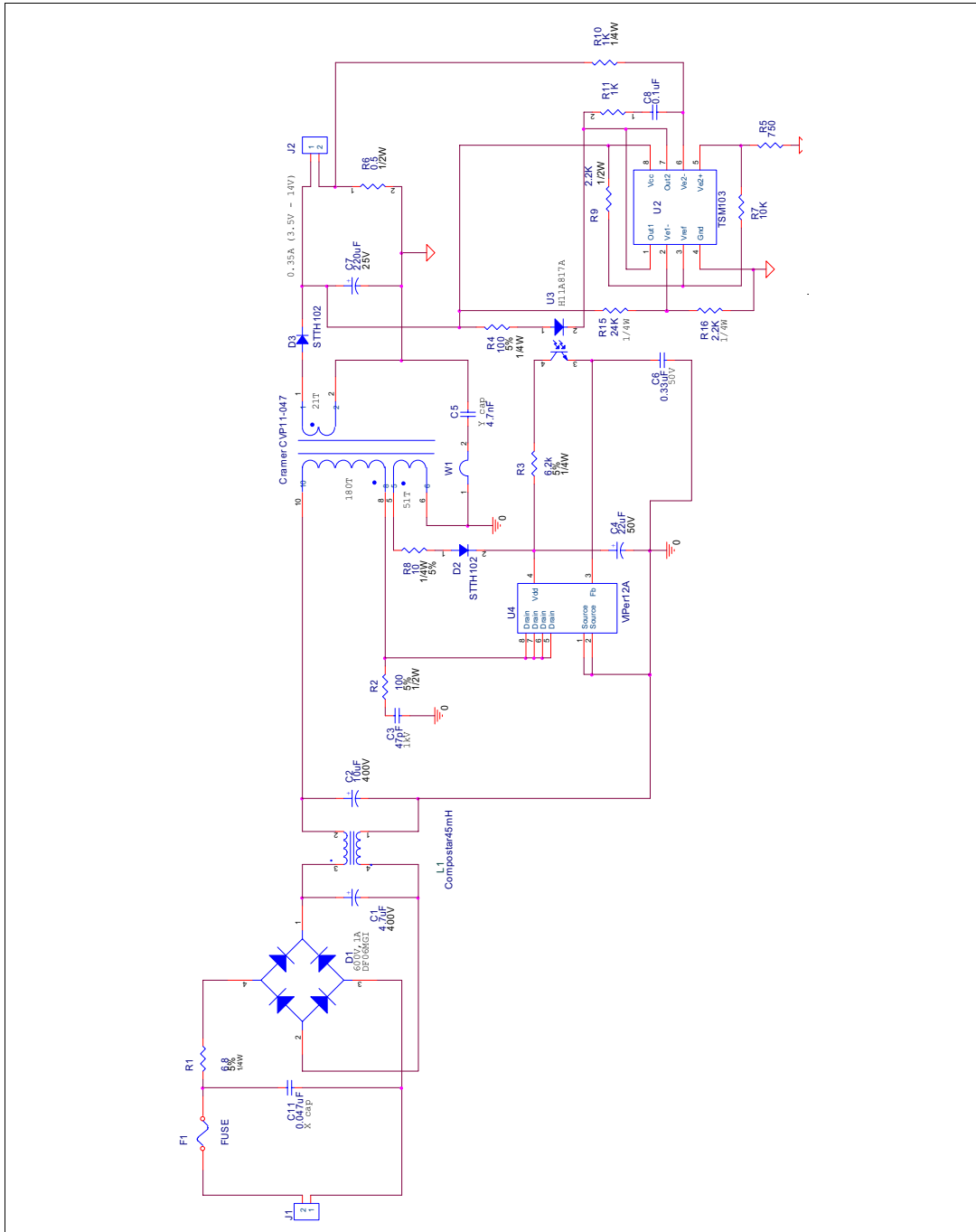

Table 12. Bill of material

Qty	Reference	Part Description	Mfg P/N	Mfg	Geometry	Mounting
1	C1	4.7uF 400V Electrolytic	TKR2GM4R7D	Compostar	Radial	TH
1	C2	10uF 400V Electrolytic	TKR2GM100D	Compostar	Radial	TH
1	C3	47pF 1kV Ceramic	ECC-D3A470JGE	Panasonic		TH
1	C4	22uF 50V Electrolytic	EEU-FC1H220	Panasonic	Radial	TH
1	C5	4.7nF 250V Ceramic	ECK-DNA472ME	Panasonic		TH
1	C6	0.33uF 50V Ceramic	ECU-S1H334KBB	Panasonic		TH
1	C7	220uF 25V Electrolytic	EEU-FC1E221	Panasonic	Radial	TH
1	C8	0.1uF 50V Ceramic	ECU-S1H104BB	Panasonic		TH
1	C11	0.047uF 250V boxcap	ECQ-U2A473MG	Panasonic		TH
1	D1	DipBridge 600V 1A	DB105	Micro Commercial	Radial	TH
1	D2	STTH102 Diode	STTH102	STMicroelectronics	Axial DO-41	TH
1	D3	STTH102 Diode	STTH102	STMicroelectronics	Axial DO-41	TH
1	F1	Fuse TR5 0.5A	3720500041	Wickman	Radial	TH
2	J1, J2	Phoenix 2 PIN Connector	MKDSN1.5/2	Phoenix Contact		TH
1	L1	45mH common mode choke	FUU10S-V24503-Q22650	Compostar		TH
1	R1	6.8Ω 5% 1/4W	Carbon Composition		Axial	TH
1	R2	100Ω 5% 0.5W			Axial	TH
1	R3	6.2kΩ 5% 0.25W			Axial	TH
1	R4	100Ω 5% 0.25W			Axial	TH
1	R5	750Ω 5% 0.25W			Axial	TH
1	R6	0.5Ω 5% 0.5W			Axial	TH
1	R7	10kΩ 5% 0.25W			Axial	TH
1	R8	10Ω 5% 0.25W			Axial	TH
1	R9	2.2kΩ 5% 0.5W			Axial	TH
2	R10, R11	1kΩ 5% 0.25W			Axial	TH
1	R15	24kΩ 5% 0.25W			Axial	TH
1	R16	2.2kΩ 5% 0.25W			Axial	TH
1	T1	Cramer Transformer	CVP11-047	Cramer Coil		TH
1	U2	Dual OpAmp&Voltage Ref.	TSM103ID	STMicroelectronics	SO8	SMD
1	U3	Optocoupler	H11A817A/LTV817A	Fairchild/LiteOn	4 Pin DIP	TH
1	U4	VIPer12A	VIPer12A DIP	STMicroelectronics	8 PIN DIP	TH
1	W1	22 Ga Solid Bus Wire				TH

Figure 6. VIPer22A constant current (350mA) LED driver schematic

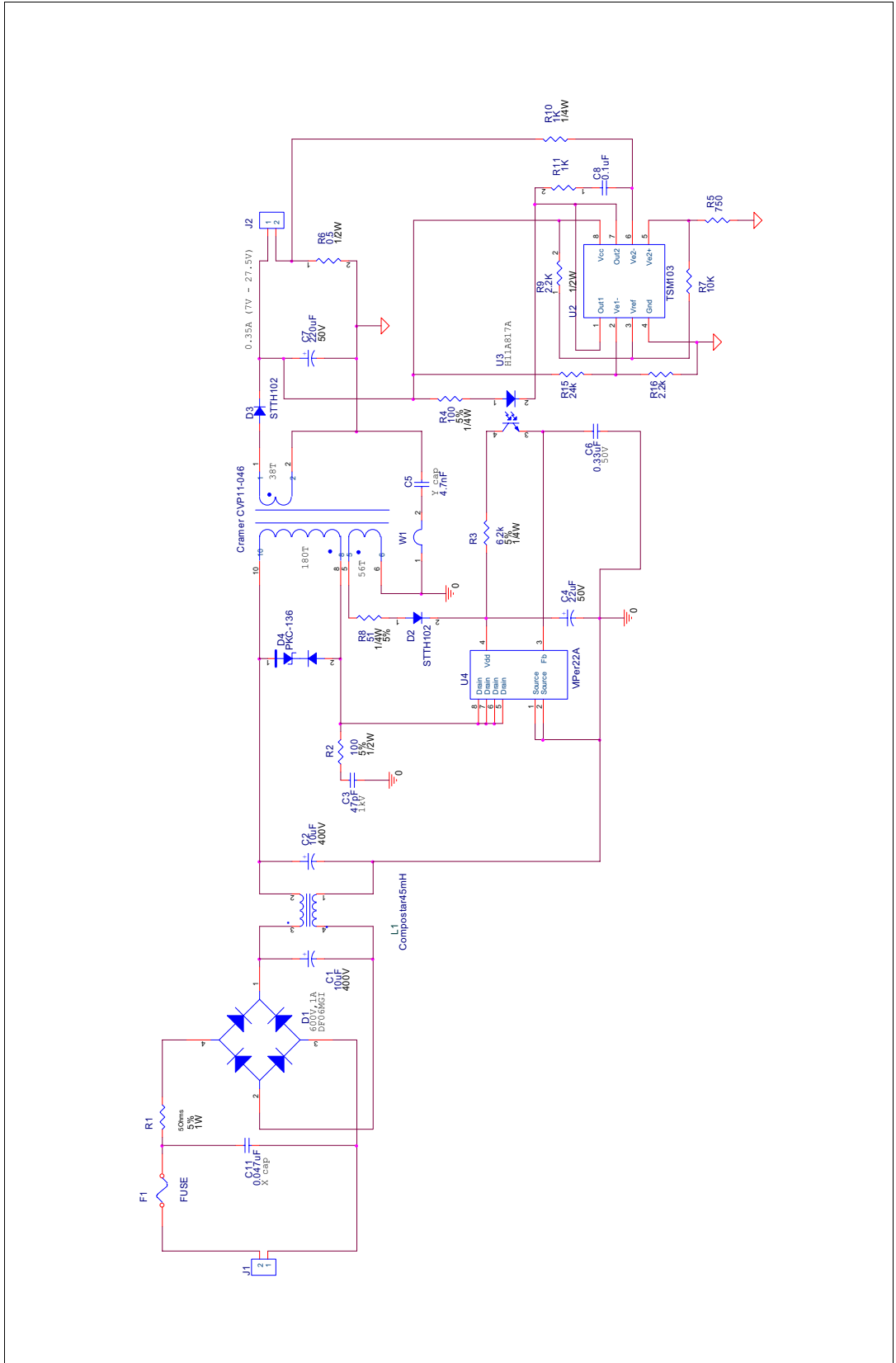

Table 13. Bill of materials

Qty	Reference	Part Description	Mfg P/N	Mfg	Geometry	Mounting
2	C1, C2	10uF 400V Electrolytic	TKR2GM100D	Compostar	Radial	TH
1	C3	47pF 1Kv Ceramic	ECC-D3A470JGE	Panasonic		TH
1	C4	22uF 50V Electrolytic	EEU-FC1H220	Panasonic	Radial	TH
1	C5	4.7nF 250V Ceramic	ECK-DNA472ME	Panasonic		TH
1	C6	0.33uF 50V Ceramic	ECU-S1H334KBB	Panasonic		TH
1	C7	220uF 50V Electrolytic	EEU-FC1H221	Panasonic	Radial	TH
1	C8	0.1uF 50V Ceramic	ECU-S1H104BB	Panasonic		TH
1	C11	0.047uF 250V boxcap	ECQ-U2A473MG	Panasonic		TH
1	D1	DipBridge 600V 1A	DB105	Micro Commercial		TH
2	D2, D3	STTH102 diode	STTH102	STMicroelectronics	Axial DO-41	TH
1	D4	Peak Clamp	PKC136	STMicroelectronics	Axial DO-15	TH
1	F1	Fuse TR5 0.5A	3720500041	Wickman	Radial	TH
2	J1, J2	Phoenix 2 Pin Conn	MKDSN1.5/2	Phoenix Contact		TH
1	L1	45mH common mode choke	FUU10S-V24503-Q22650	Compostar		TH
1	R1	5Ω 5% 1W	Wirewound		Axial	TH
1	R2	100Ω 5% 0.5W			Axial	TH
1	R3	6.2kΩ 5% 0.25W			Axial	TH
1	R4	100Ω 5% 0.25W			Axial	TH
1	R5	750Ω 5% 0.25W			Axial	TH
1	R6	0.5Ω 5% 0.5W			Axial	TH
1	R7	10kΩ 5% 0.25W			Axial	TH
1	R8	51Ω 5% 0.25W			Axial	TH
1	R9	2.2k 5% 0.5W			Axial	TH
2	R10, R11	1KΩ 5% 0.25W			Axial	TH
1	R15	24kΩ 5% 0.25W			Axial	TH
1	R16	2.2kΩ 5% 0.25W			Axial	TH
1	T1	Cramer Transformer	CVP11-046	Compostar		TH
1	U2	Dual OpAmp & Voltage Ref.	TSM103ID	STMicroelectronics	SO8	SMD
1	U3	Optocoupler	H11A817A/LTV817A	Fairchild/LiteOn	4 Pin DIP	TH
1	U4	VIPer22A	VIPer22ADIP	STMicroelectronics	8 Pin DIP	TH
1	W1	22 Ga solid bus wire			Axial	TH

3 The following components are changed for the VIPer22A constant current (350mA) LED driver configuration from the VIPer12A constant current (350mA) LED driver configuration.

**Table 14. BOM change for VIPer22A 350mA solution**

Quantity	Reference	Description
1	C1	10uF/400V electrolytic
1	C7	220uF/50V electrolytic
1	R8	51Ω5% 0.25W
1	D4	STMicroelectronics PKC-136
1	T1	Cramer Coil transformer CVP11-046
1	U4	STMicroelectronics VIPer22A

**Figure 7. VIPer12A constant current (700mA) LED driver schematic**

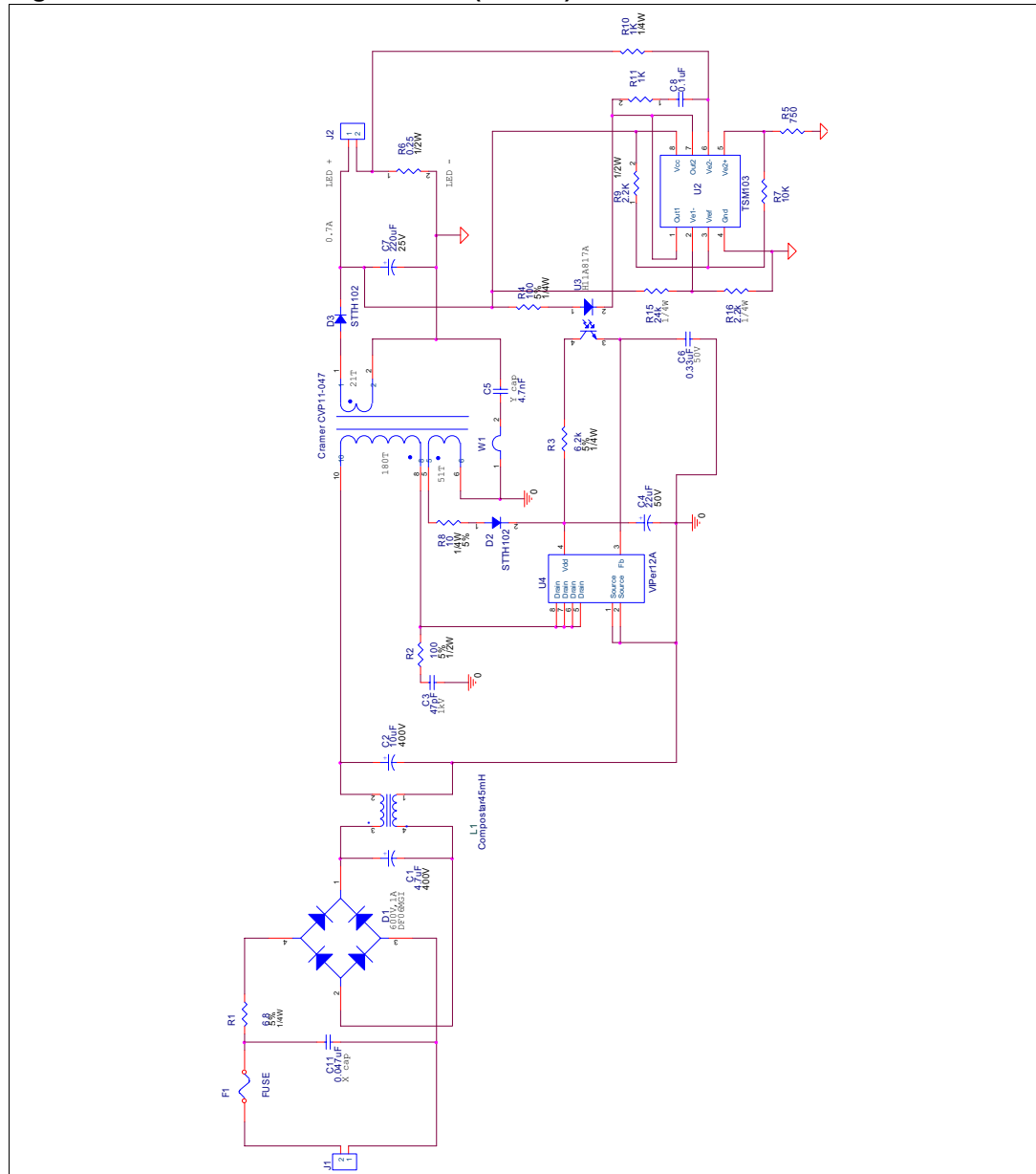

Table 15. Bill of materials

Qty	Reference	Part Description	Mfg P/N	Mfg	Geometry	Mounting
1	C1	4.7uF 400V Electrolytic	TKR2GM4R7D	Compostar	Radial	TH
1	C2	10uF 400V Electrolytic	TKR2GM100D	Compostar	Radial	TH
1	C3	47pF 1kV Ceramic	ECC-D3A470JGE	Panasonic		TH
1	C4	22uF 50V Electrolytic	EEU-FC1H220	Panasonic	Radial	TH
1	C5	4.7nF 250V Ceramic	ECK-DNA472ME	Panasonic		TH
1	C6	0.33uF 50V Ceramic	ECU-S1H334KBB	Panasonic		TH
1	C7	220uF 50V Electrolytic	EEU-FH1E221	Panasonic	Radial	TH
1	C8	0.1uF 50V Ceramic	ECU-S1H104BB	Panasonic		TH
1	C11	0.047uF 250V boxcap	ECQ-U2A473MG	Panasonic		TH
1	D1	DipBridge 600V 1A	DB105	Micro Commercial	Radial	TH
1	D2	STTH102 Diode	STTH102	STMicroelectronics	Axial DO-41	TH
1	D3	STTH102 Diode	STTH102	STMicroelectronics	Axial DO-41	TH
1	F1	Fuse TR5 0.5A	3720500041	Wickman	Radial	TH
2	J1, J2	Phoenix 2 PIN Connector	MKDSN1.5/2	Phoenix Contact		TH
1	L1	45mH common mode choke	FUU10S-V24503-Q22650	Compostar		TH
1	R1	6.8Ω5% 1/4W	Carbon Composition		Axial	TH
1	R2	100Ω5% 0.5W			Axial	TH
1	R3	6.2kΩ5% 0.25W			Axial	TH
1	R4	100Ω5% 0.25W			Radial	TH
1	R5	750Ω5% 0.25W			Radial	TH
1	R6	0.25Ω5% 0.5W			Radial	TH
1	R7	10kΩ5% 0.25W			Axial	TH
1	R8	10Ω5% 0.25W			Axial	TH
1	R9	2.2kΩ5% 0.5W			Axial	TH
2	R10, R11	1kΩ5% 0.25W			Axial	TH
1	R15	24kΩ5% 0.25W			Axial	TH
1	R16	2.2kΩ5% 0.25W			Axial	TH
1	T1	Cramer Transformer	CVP11-047	Cramer Coil		TH
1	U2	Dual OpAmp&Voltage Ref.	TSM103ID	STMicroelectronics	SO8	SMD
1	U3	Optocoupler	H11A817A/LTV817A	Fairchild/LiteOn	4 Pin DIP	TH
1	U4	VIPer12A	VIPer12A DIP	STMicroelectronics	8 Pin DIP	TH
1	W1	22 Ga Solid Bus Wire				TH

Figure 8. VIPer22A constant current (700mA) LED driver schematic

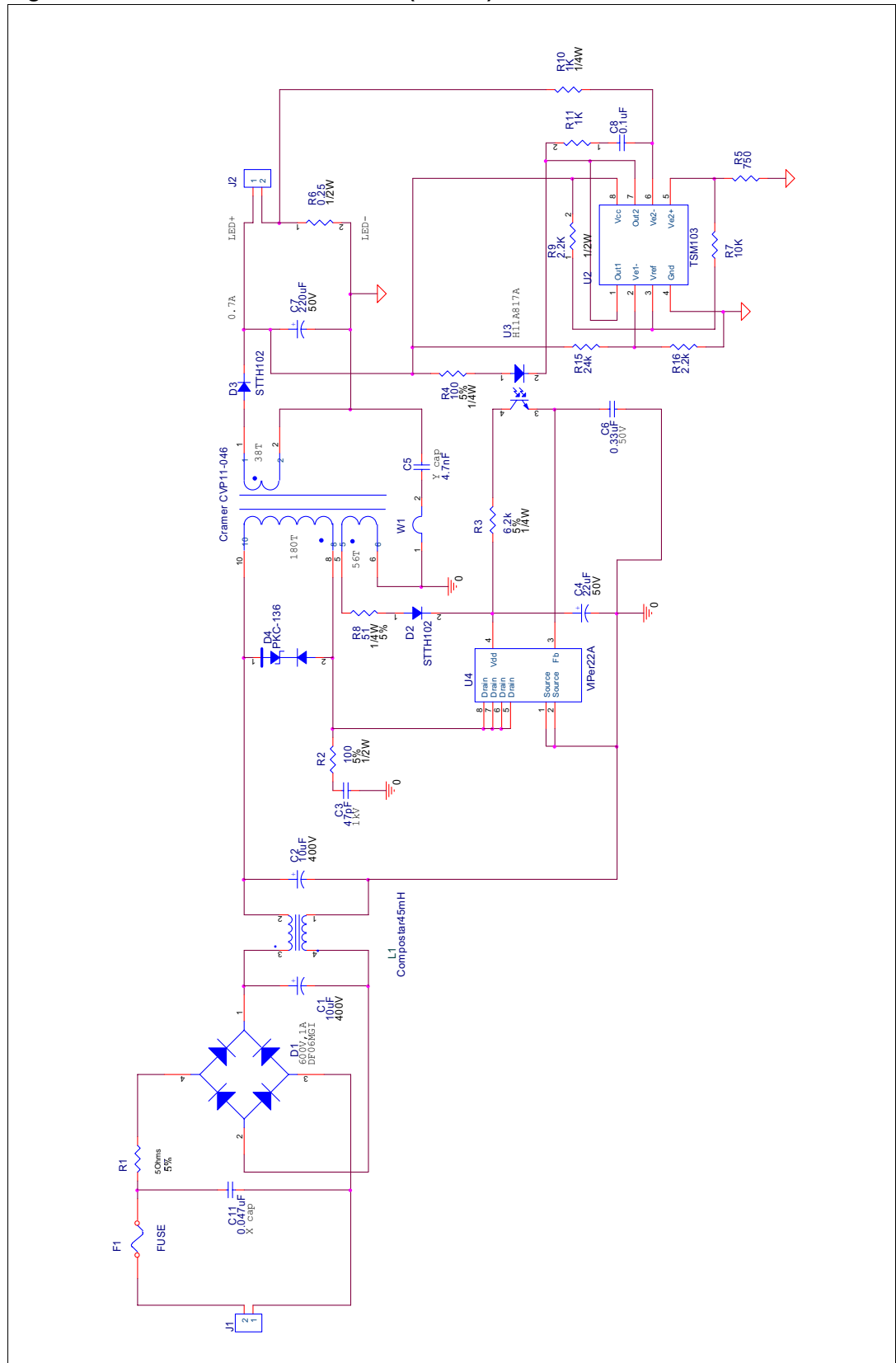

Table 16. Bill of materials

Qty	Reference	Part description	Mfg P/N	Mfg	Geometry	Mounting
2	C1, C2	10uF 400V Electrolytic	TKR2GM100D	Compostar	Radial	TH
1	C3	47pF 1Kv Ceramic	ECC-D3A470JGE	Panasonic		TH
1	C4	22uF 50V Electrolytic	EEU-FC1H220	Panasonic	Radial	TH
1	C5	4.7nF 250V Ceramic	ECK-DNA472ME	Panasonic		TH
1	C6	0.33uF 50V Ceramic	ECU-S1H334KBB	Panasonic		TH
1	C7	220uF 50V Electrolytic	EEU-FC1H221	Panasonic	Radial	TH
1	C8	0.1uF 50V Ceramic	ECU-S1H104BB	Panasonic		TH
1	C11	0.047uF 250V boxcap	ECQ-U2A473MG	Panasonic		TH
1	D1	DipBridge 600V 1A	DB105	Micro Commercial		TH
2	D2, D3	STTH102 diode	STTH102	STMicroelectronics	Axial DO-41	TH
1	D4	Peak Clamp	PKC136	STMicroelectronics	Axial DO-15	TH
1	F1	Fuse TR5 0.5A	3720500041	Wickman	Radial	TH
2	J1, J2	Phoenix 2 Pin Conn	MKDSN1.5/2	Phoenix Contact		TH
1	L1	45mH common mode choke	FUU10S-V24503-Q22650	Compostar		TH
1	R1	5Ω 5% 1W	Wirewound		Axial	TH
1	R2	100Ω 5% 0.5W			Axial	TH
1	R3	6.2kΩ 5% 0.25W			Axial	TH
1	R4	100Ω 5% 0.25W			Axial	TH
1	R5	750Ω 5% 0.25W			Axial	TH
1	R6	0.25Ω 5% 0.5W			Axial	TH
1	R7	10kΩ 5% 0.25W			Axial	TH
1	R8	51Ω 5% 0.25W			Axial	TH
1	R9	2.2kΩ 5% 0.5W			Axial	TH
1	R10, R11	1KΩ 5% 0.25W			Axial	TH
1	R15	24kΩ 5% 0.25W			Axial	TH
2	R16	2.2kΩ 5% 0.25W			Axial	TH
1	T1	Cramer Transformer	CVP11-046	Cramer Coil		TH
1	U2	Dual OpAmp & Voltage Ref.	TSM103ID	STMicroelectronics	SO8	SMD
1	U3	Optocoupler	H11A817A/LTV817A	Fairchild/LiteOn	4 Pin DIP	TH
1	U4	VIPer22A	VIPer22ADIP	STMicroelectronics	8 Pin DIP	TH
1	W1	22 Ga solid bus wire			Axial	TH



Figure 9. VIPer12A constant current (1.05A) LED driver schematic

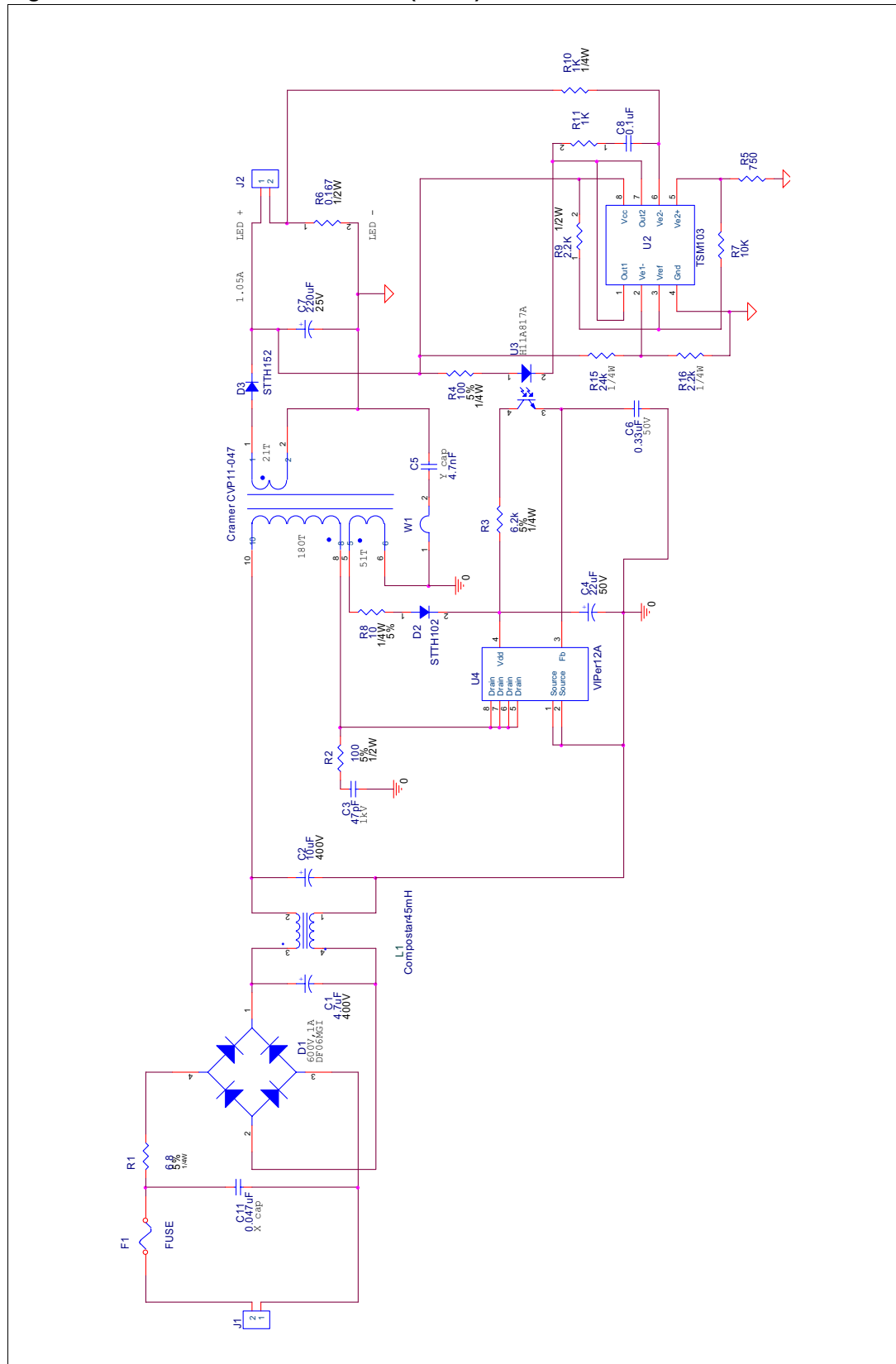

Table 17. Bill of materials

Qty	Reference	Part Description	Mfg P/N	Mfg	Geometry	Mounting
1	C1	4.7uF 400V Electrolytic	TKR2GM4R7D	Compostar	Radial	TH
1	C2	10uF 400V Electrolytic	TKR2GM100D	Compostar	Radial	TH
1	C3	47pF 1kV Ceramic	ECC-D3A470JGE	Panasonic		TH
1	C4	22uF 50V Electrolytic	EEU-FC1H220	Panasonic	Radial	TH
1	C5	4.7nF 250V Ceramic	ECK-DNA472ME	Panasonic		TH
1	C6	0.33uF 50V Ceramic	ECU-S1H334KBB	Panasonic		TH
1	C7	220uF 50V Electrolytic	EEU-FH1E221	Panasonic	Radial	TH
1	C8	0.1uF 50V Ceramic	ECU-S1H104BB	Panasonic		TH
1	C11	0.047uF 250V boxcap	ECQ-U2A473MG	Panasonic		TH
1	D1	DipBridge 600V 1A	DB105	Micro Commercial	Radial	TH
1	D2	STTH102 Diode	STTH102	STMicroelectronics	Axial DO-41	TH
1	D3	STTH152 Diode	STTH152	STMicroelectronics	Axial DO-41	TH
1	F1	Fuse TR5 0.5A	3720500041	Wickman	Radial	TH
2	J1, J2	Phoenix 2 PIN Connector	MKDSN1.5/2	Phoenix Contact		TH
1	L1	45mH common mode choke	FUU10S-V24503-Q22650	Compostar		TH
1	R1	6.8Ω 5% 1/4W	Carbon Composition		Axial	TH
1	R2	100Ω 5% 0.5W			Axial	TH
1	R3	6.2kΩ 5% 0.25W			Axial	TH
1	R4	100Ω 5% 0.25W			Axial	TH
1	R5	750Ω 5% 0.25W			Axial	TH
1	R6	0.167Ω 5% 0.5W			Axial	TH
1	R7	10kΩ 5% 0.25W			Axial	TH
1	R8	10Ω 5% 0.25W			Axial	TH
1	R9	2.2kΩ 5% 0.5W			Axial	TH
2	R10, R11	1kΩ 5% 0.25W			Axial	TH
1	R15	24kΩ 5% 0.25W			Axial	TH
1	R16	2.2kΩ 5% 0.25W			Axial	TH
1	T1	Cramer Transformer	CVP11-047	Cramer Coil		TH
1	U2	Dual OpAmp&Voltage Ref.	TSM103ID	STMicroelectronics	SO8	SMD

Table 17. Bill of materials

Qty	Reference	Part Description	Mfg P/N	Mfg	Geometry	Mounting
1	U3	Optocoupler	H11A817A/LTV817A	Fairchild/LiteOn	4 Pin DIP	TH
1	U4	VIPer12A	VIPer12A DIP	STMicroelectronics	8 Pin DIP	TH
1	W1	22 Ga Solid Bus Wire				TH

Figure 10. VIPer22A constant current (1.05A) LED driver schematic

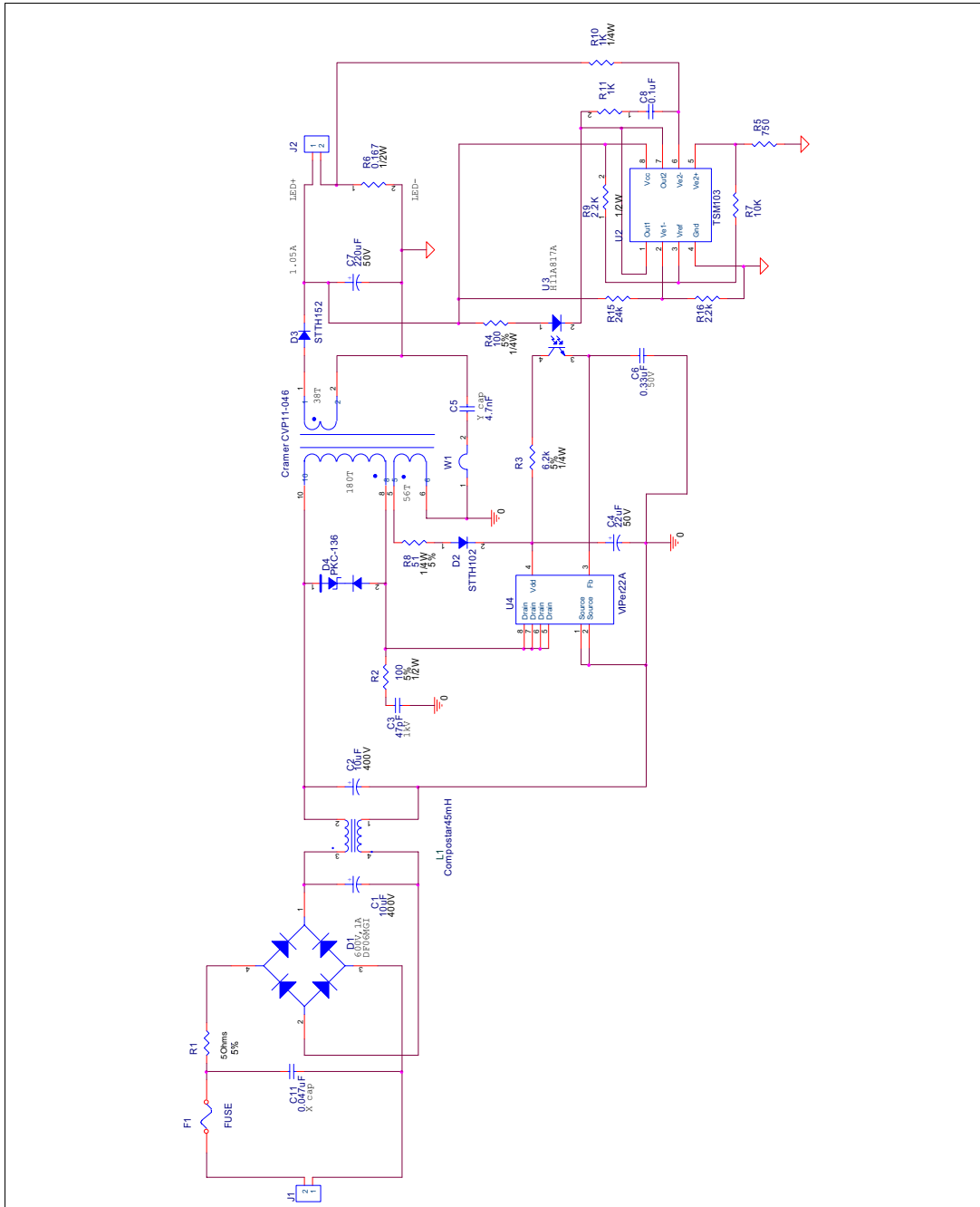

Table 18. Bill of materials

Qty	Reference	Part Description	Mfg P/N	Mfg	Geometry	Mounting
2	C1, C2	10uF 400V Electrolytic	TKR2GM100D	Compostar	Radial	TH
1	C3	47pF 1Kv Ceramic	ECC-D3A470JGE	Panasonic		TH
1	C4	22uF 50V Electrolytic	EEU-FC1H220	Panasonic	Radial	TH
1	C5	4.7nF 250V Ceramic	ECK-DNA472ME	Panasonic		TH
1	C6	0.33uF 50V Ceramic	ECU-S1H334KBB	Panasonic		TH
1	C7	220uF 50V Electrolytic	EEU-FC1H221	Panasonic	Radial	TH
1	C8	0.1uF 50V Ceramic	ECU-S1H104BB	Panasonic		TH
1	C11	0.047uF 250V boxcap	ECQ-U2A473MG	Panasonic		TH
1	D1	DipBridge 600V 1A	DB105	Micro Commercial		TH
1	D2	STTH102 diode	STTH102	STMicroelectronics	Axial DO-41	TH
1	D3	STTH152 diode	STTH152	STMicroelectronics	Axial DO-41	TH
1	D4	Peak Clamp	PKC136	STMicroelectronics	Axial DO-15	TH
1	F1	Fuse TR5 0.5A	3720500041	Wickman	Radial	TH
2	J1, J2	Phoenix 2 Pin Conn	MKDSN1.5/2	Phoenix Contact		TH
1	L1	45mH common mode choke	FUU10S-V24503-Q22650	Compostar		TH
1	R1	5Ω5% 1W	Wirewound		Axial	TH
1	R2	100Ω5% 0.5W			Axial	TH
1	R3	6.2kΩ5% 0.25W			Axial	TH
1	R4	100Ω5% 0.25W			Axial	TH
1	R5	750Ω5% 0.25W			Axial	TH
1	R6	0.167Ω5% 0.5W			Axial	TH
1	R7	10kΩ5% 0.25W			Axial	TH
1	R8	51Ω5% 0.25W			Axial	TH
1	R9	2.2kΩ5% 0.5W			Axial	TH
2	R10, R11	1KΩ5% 0.25W			Axial	TH
1	R15	24kΩ5% 0.25W			Axial	TH
1	R16	2.2kΩ5% 0.25W			Axial	TH
1	T1	Cramer Transformer	CVP11-046	Cramer Coil		TH
1	U2	Dual OpAmp & Voltage Ref.	TSM103ID	STMicroelectronics	SO8	SMD
1	U3	Optocoupler	H11A817A/LTV817A	Fairchild/LiteOn	4 Pin DIP	TH
1	U4	VIPer22A	VIPer22ADIP	STMicroelectronics	8 Pin DIP	TH
1	W1	22 Ga solid bus wire			Axial	TH

## 7 PCB layout

Figure 11. Board top side (not in scale)

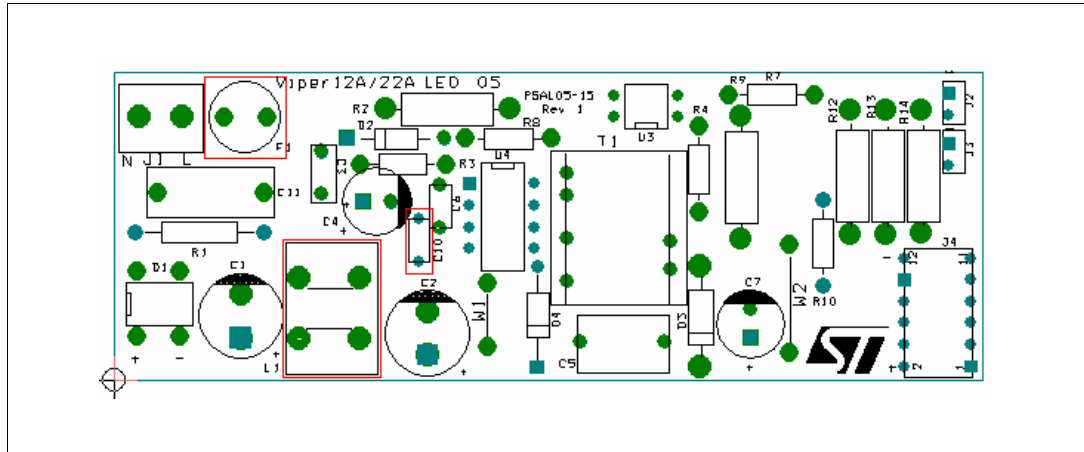
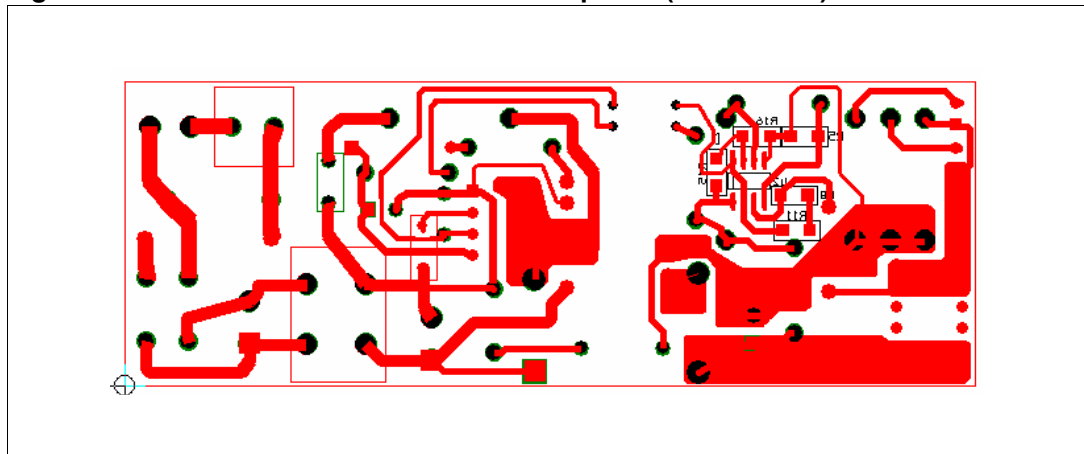

Figure 12. Board bottom side viewed from top side (not in scale)



## 8 General circuit description

The design operates from 90 to 264Vac input. The AC input is rectified and filtered by the bridge BR1 to generate the high voltage DC bus that is applied to the primary winding of the transformer, CVP11-04X. C1, L1, C2, and C11 provide EMI filtering for the circuit.

A snubber circuit that consists of R2 and C3 reduces the leakage spike and voltage ringing on the drain pin of VIPerX2A, thereby provides additional EMI filtering. A transil, PKC-136, is used to clamp the drain voltage at a safe level for the VIPer22A constant current LED driver configuration because of the extra power level.

The current is controlled by monitoring the voltage drop across the sense resistor, R6. The non-inverting input of the operational amplifier inside TSM103 is set to 175mV through the resistors divider, R5 and R7. This operational amplifier will then regulate the inverting input to 175mV by adjusting its output by changing the current going through the optocoupler, H11A817A (U3). The gain of the transistor inside the optocoupler then controls the feedback loop of VIPerX2A.

The LED drive current is given by the equation:

$$I_{out} = 0.175V/R6$$

C6, C8, and R11 are utilized to ensure the stability of the circuit. C7 reduces the ripple current. As a safety measure, a resistor divider consisting of R15 and R16 is added to clamp the output voltage fed back into TSM103 so that it does not exceed the maximum voltage rating of U2, TSM103 for a no load condition at the output.

# 9 Waveforms

Figure 13. shows VDD, Vout, and VDS at 375Vdc with one LED at the output for the VIPer12A constant current LED driver configuration while Figure 14. shows likewise with four LEDs at the output.

Figure 13. VIPer12A with 1 LED at output

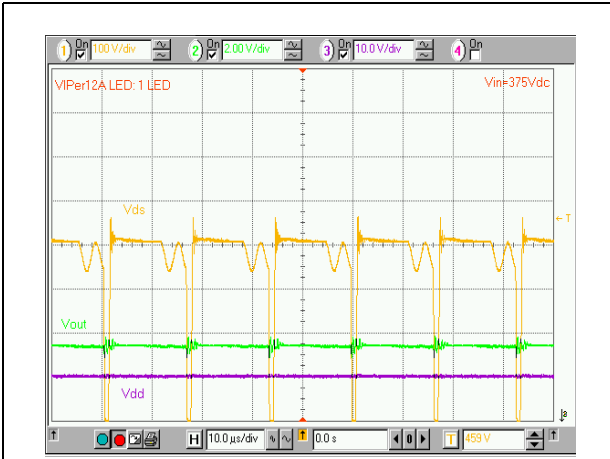

Figure 14. VIPer12A with 4 LEDs at output



The drain to source voltage, VDD, and Vout waveforms are shown in Figure 15. and Figure 16., taken at 375Vdc for two and eight LEDs at the output respectively. It can be seen at worse case condition, the voltages across the device are not exceeded.

Figure 15. VIPer22A with 2 LEDs at output



Figure 16. VIPer22A with 8 LEDs at output



# 10 EMI results

Both VIPer12A and VIPer22A constant current LED driver configurations were designed to pass EN55022 Class B EMI at 120Vac input. Peak EMI is met with a comfortable margin.

Figure 17. VIPer12A EMI

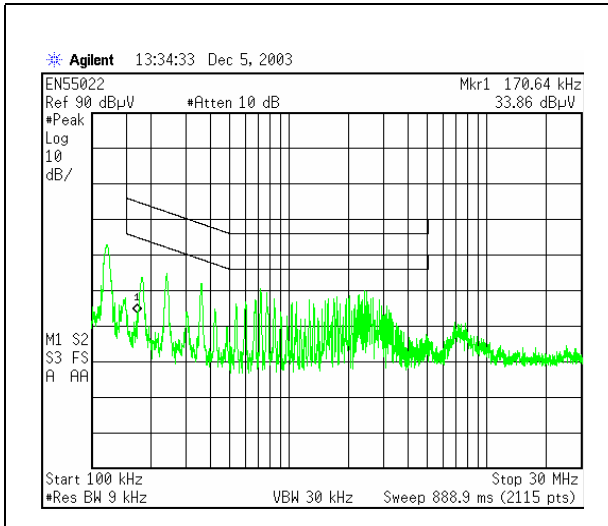
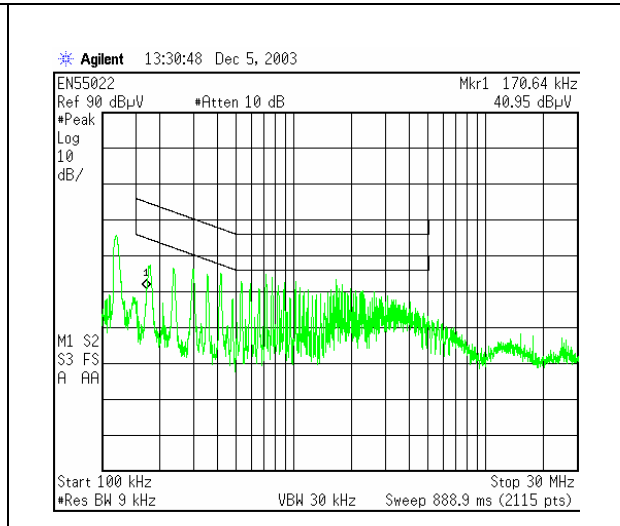

Figure 18. VIPer22A EMI





# 11 Current regulation

The VIPer12A and the VIPer22A have excellent regulation as shown in [Figure 19](#). and [Figure 20](#).

Figure 19. VIPer12A current regulation

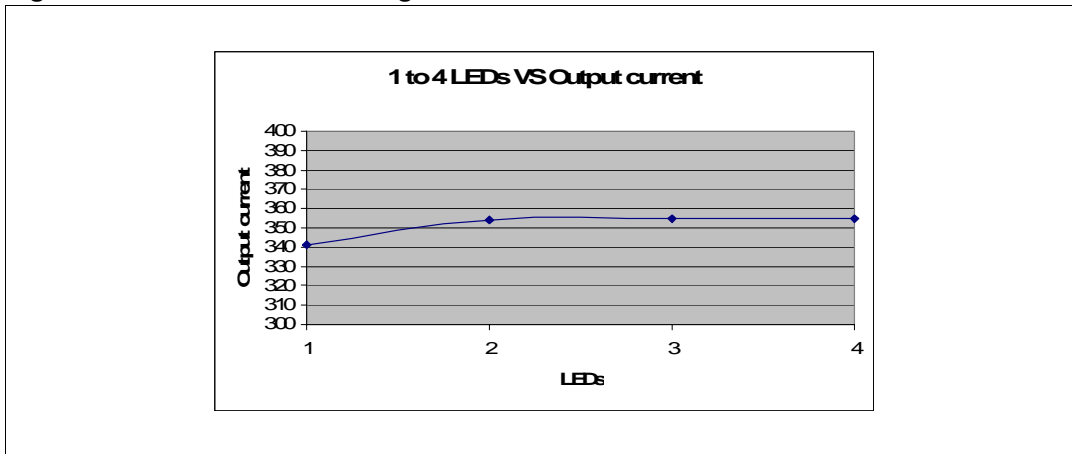
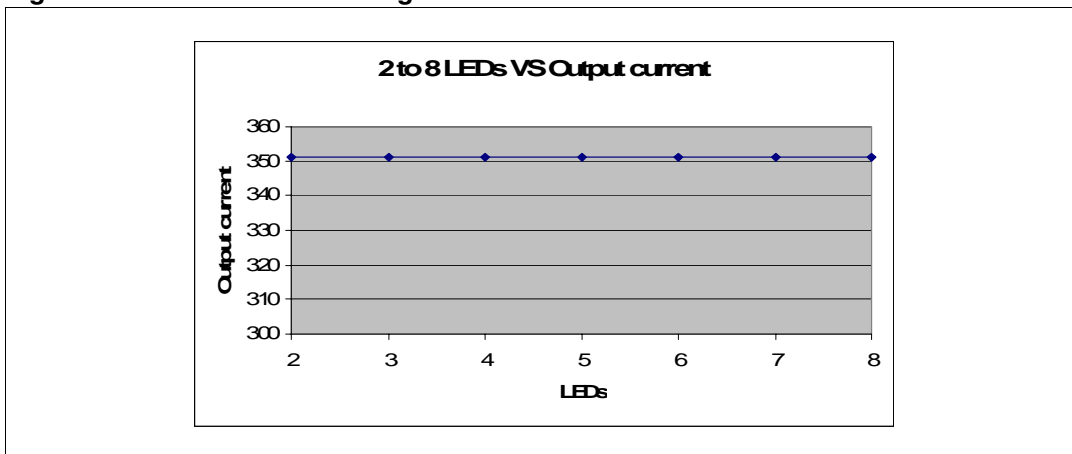

Figure 20. VIPer22A current regulation



## 12 Ripple current

The ripple current measured at 90Vac with one LED at the output is 59mVpp and it is 57mVpp at 264Vac input for the VIPer12A constant current LED driver configuration. With four LEDs at the output the measured ripple current is 46mVpp at 264Vac input.

*Figure 22.* shows the ripple current measurements for the VIPer22A constant current LED driver configuration. Here, the measured ripple is 26mVpp at 264Vac input with 2 LEDs at the output while the ripple is 19.5mVpp for 8 LEDs at the output.

**Figure 21. Ripple at 264Vac (VIPer12A)**

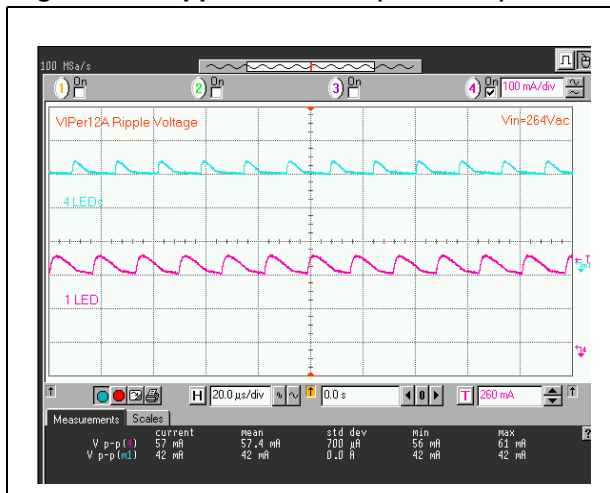

**Figure 22. Ripple at 264Vac (VIPer22A)**



## 13 1.8" Round LED board configuration

Another version is available of the rectangular VIPer12A LED driver and VIPer22A LED driver boards that fits inside a round 1.8" in diameter light fixture. The following sections will describe the layout and performance of this board.

# 14 Round LED board layout

Figure 23. Top Side of Board (not in scale)

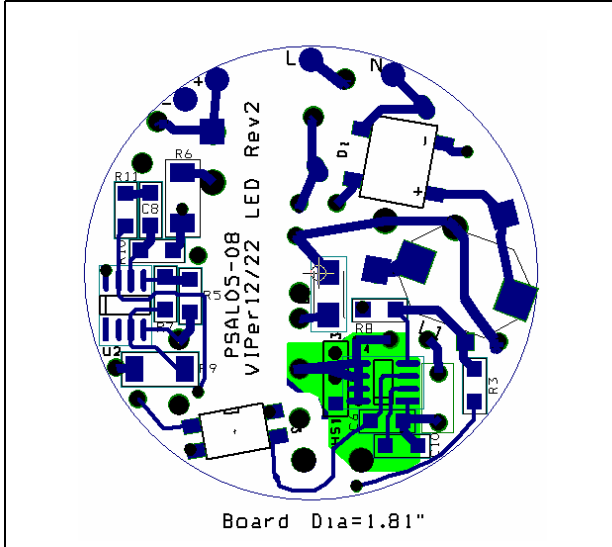

Figure 24. Bottom Side of Board (not in scale)

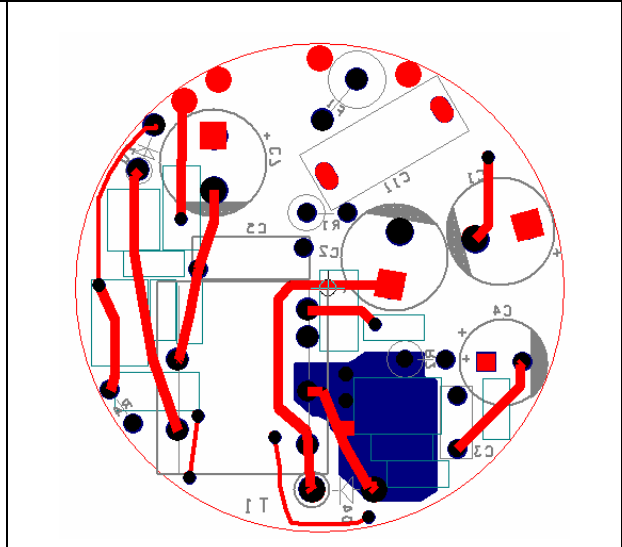

Figure 25. Top board layout

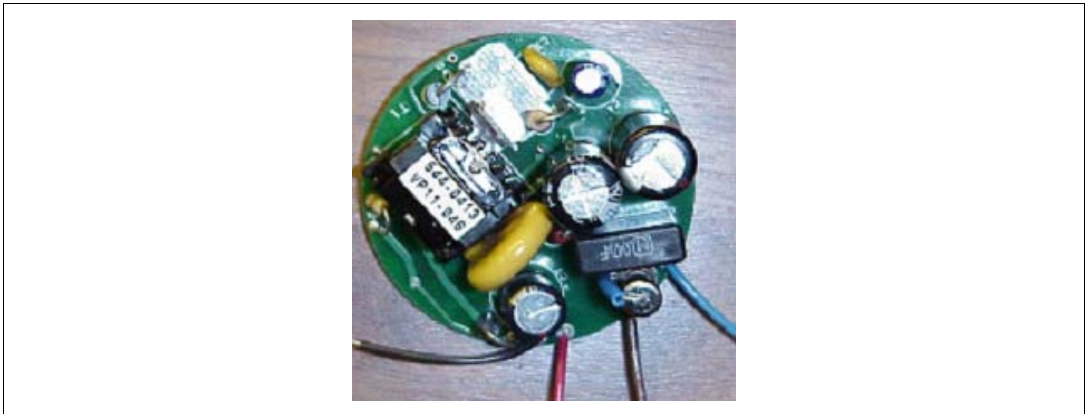
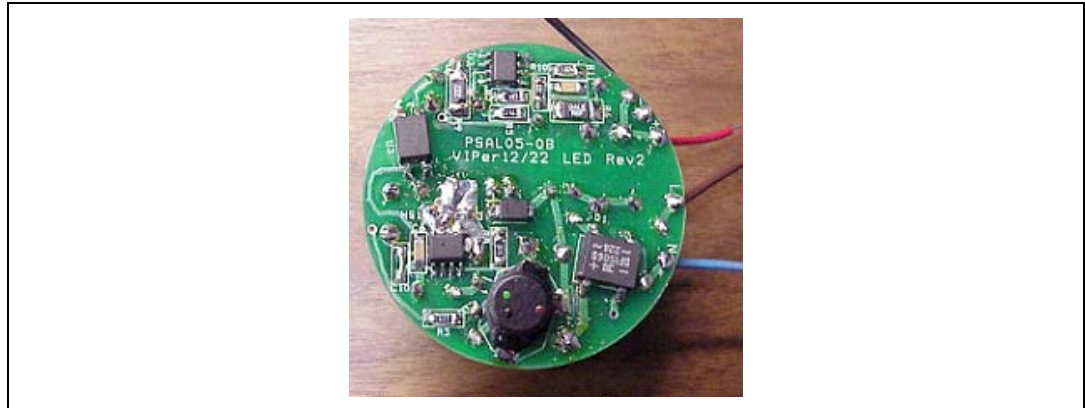

Figure 26. Bottom board layout



# 15 EMI result

The VIPer22A LED driver round board passes EN55022 Class B EMI at 120Vac input as shown in [Figure 27](#). below. [Figure 28](#). shows the EMI results at 120Vac input for VIPer12A round LED driver board.

**Figure 27. VIPer22A round LED EMI**

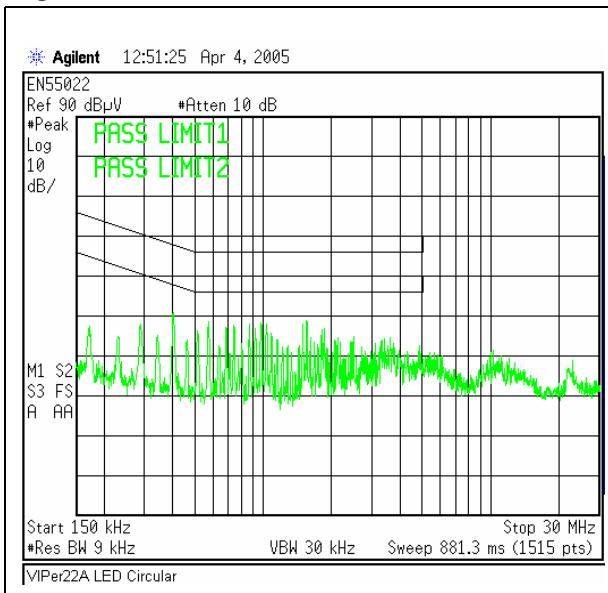

**Figure 28. VIPer12A round LED EMI**

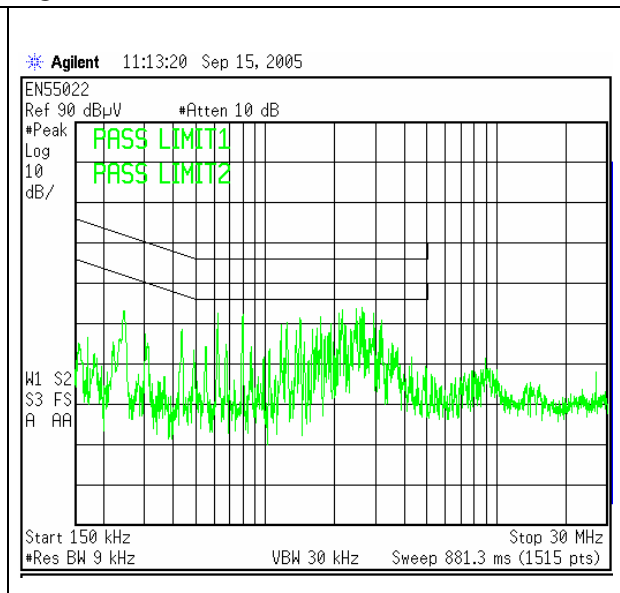

# 16 Current regulation

The current regulation measured is  $\pm 0.15\%$  at 120Vac input with 2 to 8 LEDs at the output for the VIPer22A round LED driver board.

Figure 29. VIPer22A round LED board current regulation

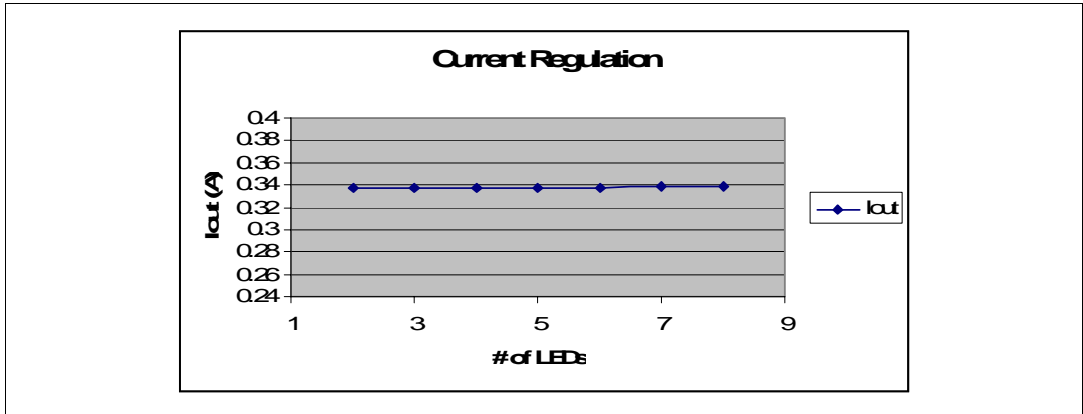
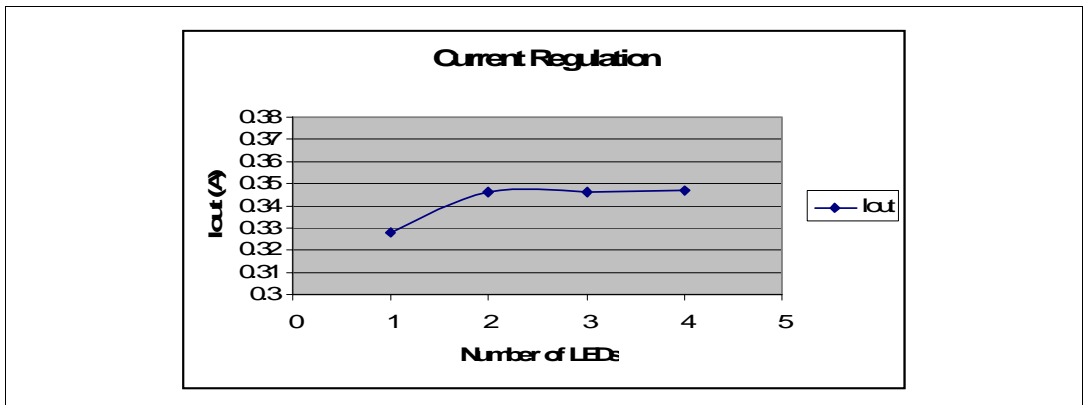

Figure 30. VIPer12A round LED board current regulation



# 17 Ripple current

Figure 31. below shows the ripple current measured with 2 LEDs and 8 LEDs at the output for 264Vac input for the VIPer22A round LED driver board. With 2 LEDs at the output, the measured ripple current is 51mApp while the ripple is 43mApp for 8 LEDs at the output. With 1 LED at the output for the VIPer12A round LED driver board, the measured ripple current is 65mApp and 45mApp for 4 LEDs at the output.

Figure 31. Ripple Current at 264Vac input (VIPer22A)

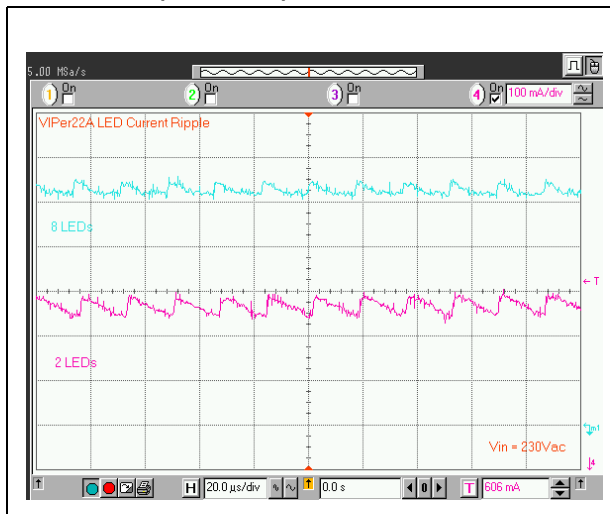

Figure 32. Ripple Current at 264Vac input (VIPer12A)



# 18 Low cost option

A lower cost alternative to the isolated VIPer12A power supply is to use the VIPer22A in a non-isolated Buck configuration as shown in [Figure 33](#). The circuit uses fewer and less expensive parts for systems that do not require safety isolation.

**Figure 33. Non-isolated buck configuration schematic**

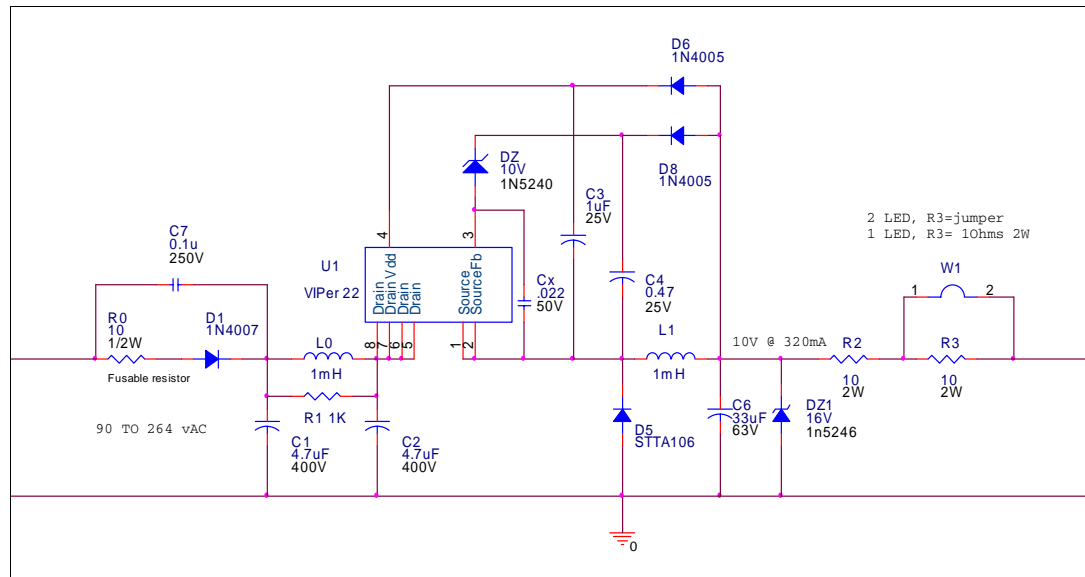

C1, L0, and C2 form an EMI filter to meet emission standards. D6, C3 maintain voltage for Vdd. L1 and C6 form the output filter to average the DC output. The output is voltage regulated at 10V by the zener diode DZ1. R2 drops the voltage and sets the current to approximately 330mA. A different value resistor can be used to set the current to a value up to 370mA which is the limiting factor of L1, the output inductor. This unit will drive 2 LEDs or 1 LED by cutting one jumper before use. To drive 1 LED only, the jumper can be cut, placing a second resistor in series with the output to drop additional voltage. This is not as efficient as the previous design but simpler and less expensive.

The output is set to 10V because that is the minimum output voltage that will drive the VIPer22A with these minimum parts. With the addition of an inductor, 2 of 1N4005 and a small capacitor, a lower voltage can be designed to increase the efficiency.

**Table 19. Bill of materials**

Quantity	Reference	Description
1	Cx	0.022uF/50V 1206SM
2	C1, C2	4.7uF/400V electrolytic
1	C3	1uF/25V electrolytic
1	C4	0.47uF/25V 1206SM
1	C6	33uF/63V low ESR
1	C7	0.1uF/630V poly
1	DZ	1N5240 (10V)



Table 19. Bill of materials

Quantity	Reference	Description
1	DZ1	1N5246 (16V)
1	D1	1N4007
1	D5	STMicroelectronics STTA106
2	D6, D8	1N4005
1	L0	1mH 160mA JW Miller 5300-37
1	L1	1mH 400mA Compostar Q3277
1	R0	10 $\Omega$ 1/2W fusable resistor
1	R1	1k $\Omega$ 1/4W
2	R2, R3	10 $\Omega$ 2W
1	U1	STMicroelectronics VIPer22A
1	W1	Jumper wire

## 19 PCB layout

Below is a reference design of the VIPer22A-Buck LED driver above. The board measures 67mm x 26mm.

**Figure 34. VIPer22A buck board layout**

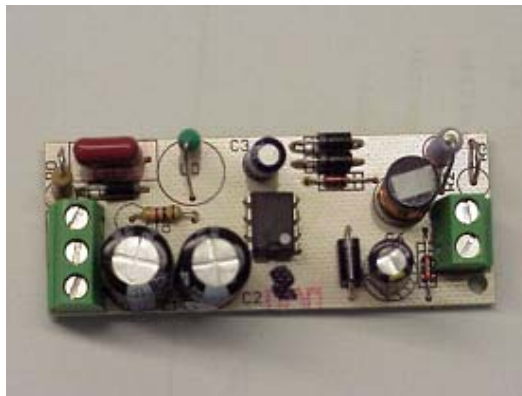

## 20 Conclusion

We have shown two isolated and one non-isolated off line power supplies to efficiently drive LEDs in series.

## 21 Revision history

**Table 20. Document revision history**

<b>Date</b>	<b>Revision</b>	<b>Changes</b>
10-Sep-2004	1	Initial release
18-Jan-2006	2	Various changes
03-May-2006	3	- New template - Various changes
10-Aug-2006	4	- New template - Component list value modified - Schematic diagram modified

**Please Read Carefully:**

Information in this document is provided solely in connection with ST products. STMicroelectronics NV and its subsidiaries ("ST") reserve the right to make changes, corrections, modifications or improvements, to this document, and the products and services described herein at any time, without notice.

All ST products are sold pursuant to ST's terms and conditions of sale.

Purchasers are solely responsible for the choice, selection and use of the ST products and services described herein, and ST assumes no liability whatsoever relating to the choice, selection or use of the ST products and services described herein.

No license, express or implied, by estoppel or otherwise, to any intellectual property rights is granted under this document. If any part of this document refers to any third party products or services it shall not be deemed a license grant by ST for the use of such third party products or services, or any intellectual property contained therein or considered as a warranty covering the use in any manner whatsoever of such third party products or services or any intellectual property contained therein.

**UNLESS OTHERWISE SET FORTH IN ST'S TERMS AND CONDITIONS OF SALE ST DISCLAIMS ANY EXPRESS OR IMPLIED WARRANTY WITH RESPECT TO THE USE AND/OR SALE OF ST PRODUCTS INCLUDING WITHOUT LIMITATION IMPLIED WARRANTIES OF MERCHANTABILITY, FITNESS FOR A PARTICULAR PURPOSE (AND THEIR EQUIVALENTS UNDER THE LAWS OF ANY JURISDICTION), OR INFRINGEMENT OF ANY PATENT, COPYRIGHT OR OTHER INTELLECTUAL PROPERTY RIGHT.**

**UNLESS EXPRESSLY APPROVED IN WRITING BY AN AUTHORIZED ST REPRESENTATIVE, ST PRODUCTS ARE NOT RECOMMENDED, AUTHORIZED OR WARRANTED FOR USE IN MILITARY, AIR CRAFT, SPACE, LIFE SAVING, OR LIFE SUSTAINING APPLICATIONS, NOR IN PRODUCTS OR SYSTEMS WHERE FAILURE OR MALFUNCTION MAY RESULT IN PERSONAL INJURY, DEATH, OR SEVERE PROPERTY OR ENVIRONMENTAL DAMAGE. ST PRODUCTS WHICH ARE NOT SPECIFIED AS "AUTOMOTIVE GRADE" MAY ONLY BE USED IN AUTOMOTIVE APPLICATIONS AT USER'S OWN RISK.**

Resale of ST products with provisions different from the statements and/or technical features set forth in this document shall immediately void any warranty granted by ST for the ST product or service described herein and shall not create or extend in any manner whatsoever, any liability of ST.

ST and the ST logo are trademarks or registered trademarks of ST in various countries.

Information in this document supersedes and replaces all information previously supplied.

The ST logo is a registered trademark of STMicroelectronics. All other names are the property of their respective owners.

© 2006 STMicroelectronics - All rights reserved

STMicroelectronics group of companies

Australia - Belgium - Brazil - Canada - China - Czech Republic - Finland - France - Germany - Hong Kong - India - Israel - Italy - Japan - Malaysia - Malta - Morocco - Singapore - Spain - Sweden - Switzerland - United Kingdom - United States of America

[www.st.com](http://www.st.com)