

Connector colours

Nr	Black	Or	Orange
Be	Blue	Rg	Red
Mr	Brown	Ba	White
Gr	Grey	Jn	Yellow
Ve	Green		

Key to items

1	Battery	42	Driver's seatbelt pretensioner	51	Headlight adjustment switch
2	Ignition switch	43	Passenger's airbag	52	LH headlight adjustment motor
3	Engine fuse box	44	Driver's airbag	53	RH headlight adjustment motor
4	Passenger fuse box	45	Clock spring	54	Electric window relay
8	Diagnostic connector	46	ABS module	55	LH window switch
24	Steering wheel switches	47	LH front wheel sensor	56	RH window switch
25	Brake light switch	48	RH front wheel sensor	57	Electric window module
40	Airbag module	49	LH rear wheel sensor	58	LH window motor
41	Passenger's seatbelt pretensioner	50	RH rear wheel sensor	59	RH window motor

Diagram 4

MTS  
H33270

Airbag

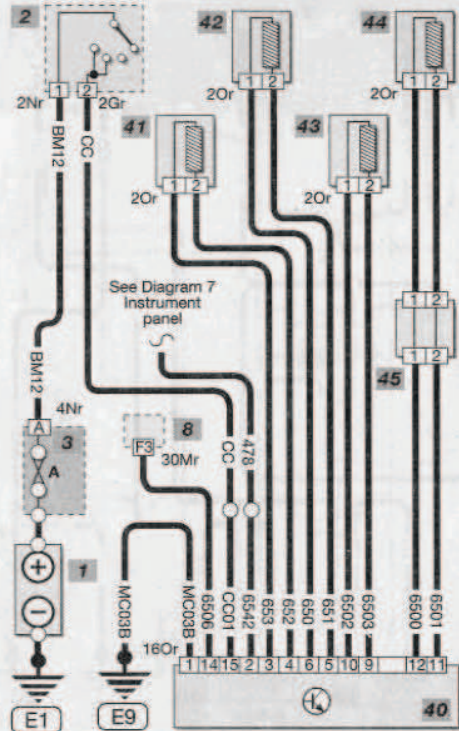

ABS

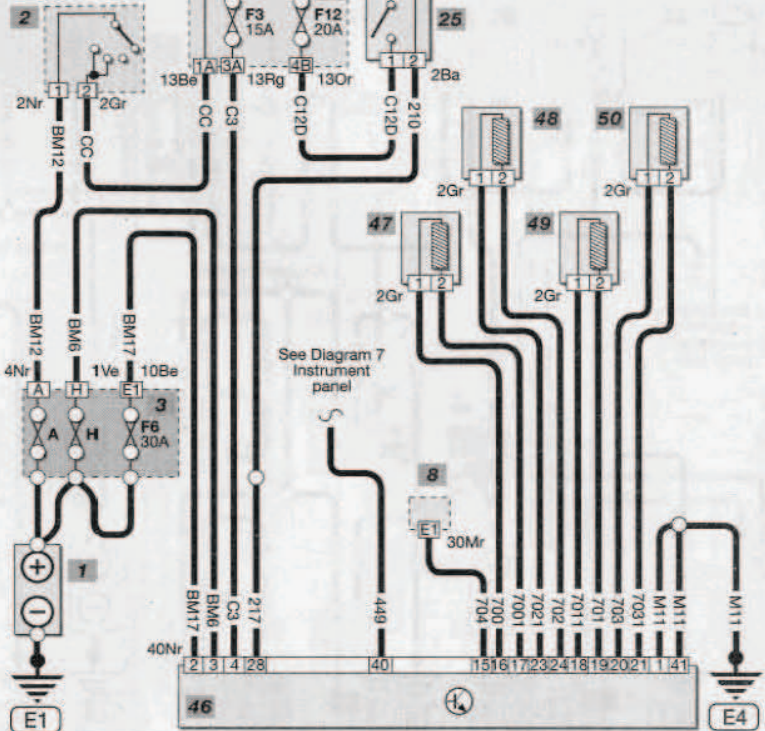

Headlight adjustment

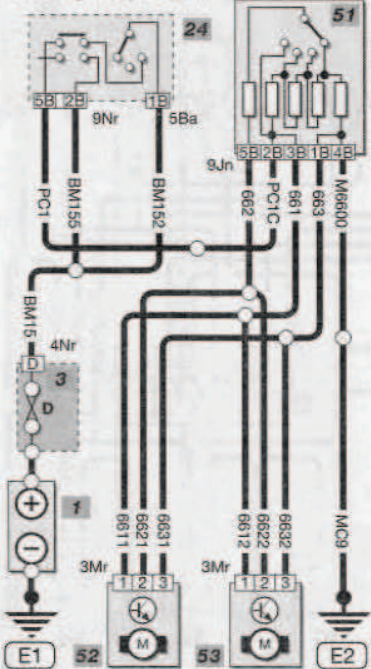

Electric windows

