

VIDEO SWITCH MATRIX

■ GENERAL DESCRIPTION

The **NJM2277** is a Video switch for Set Top Box, and TV.
 The **NJM2277** includes 2 CVBS input, 2-RGB input switches.
 Also it allow the inputs to be routed in 3 CVBS output, 1-RGB output.
 The **NJM2277** includes 5th-order Low pass Filter suppress
 the noise interference to video signal.
 The **NJM2277** enable to control the Output Impedance for RGB outputs.

■ PACKAGE OUTLINE

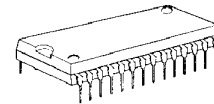

NJM2277L

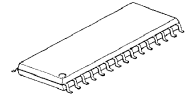

NJM2277M

■ FEATURES

- Operating Voltage $\pm 5V$
- 2- RGB Switches.
- 75 Ω Cable Driver on all channels.
- 41dB Stop Band Rejection (@27MHz)
- Bipolar Technology
- Package Outline SDIP28, SDMP30
- 2-Input,3-output CVBS Switches.
- Quad 5th order Butter worth Low Pass Filter.
- High Impedance output for RGB signal.

■ FUNCTION BLOCK DIAGRAM

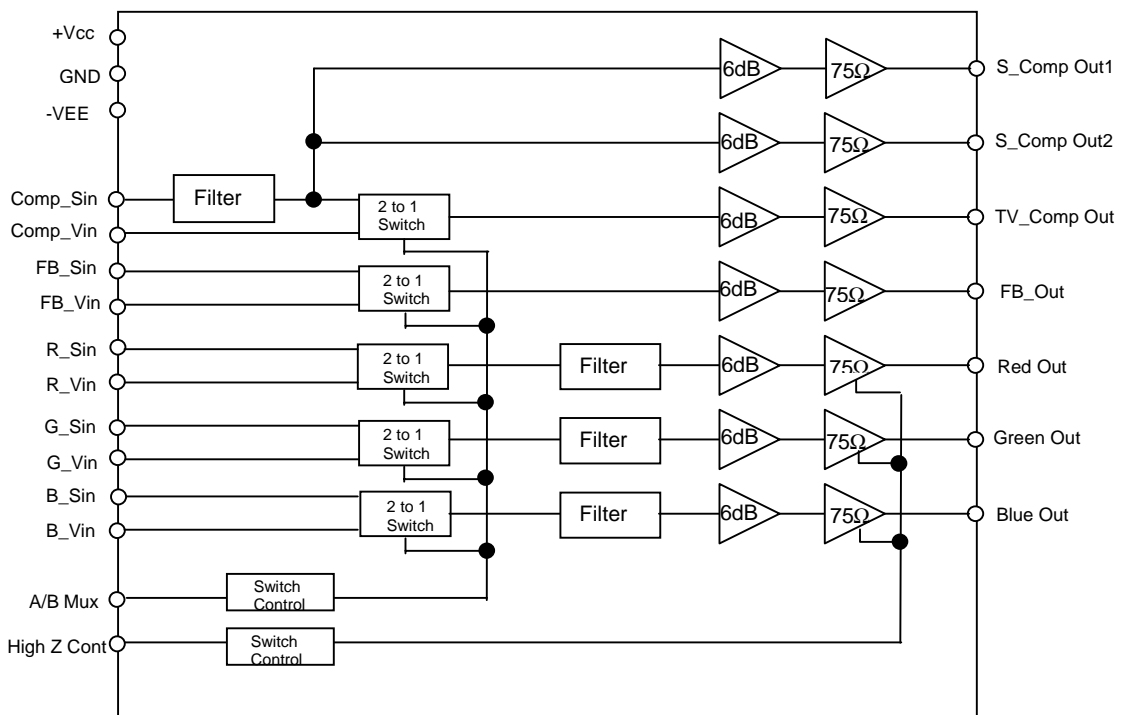

NJM2277

■ Pin Configuration (SDIP28)

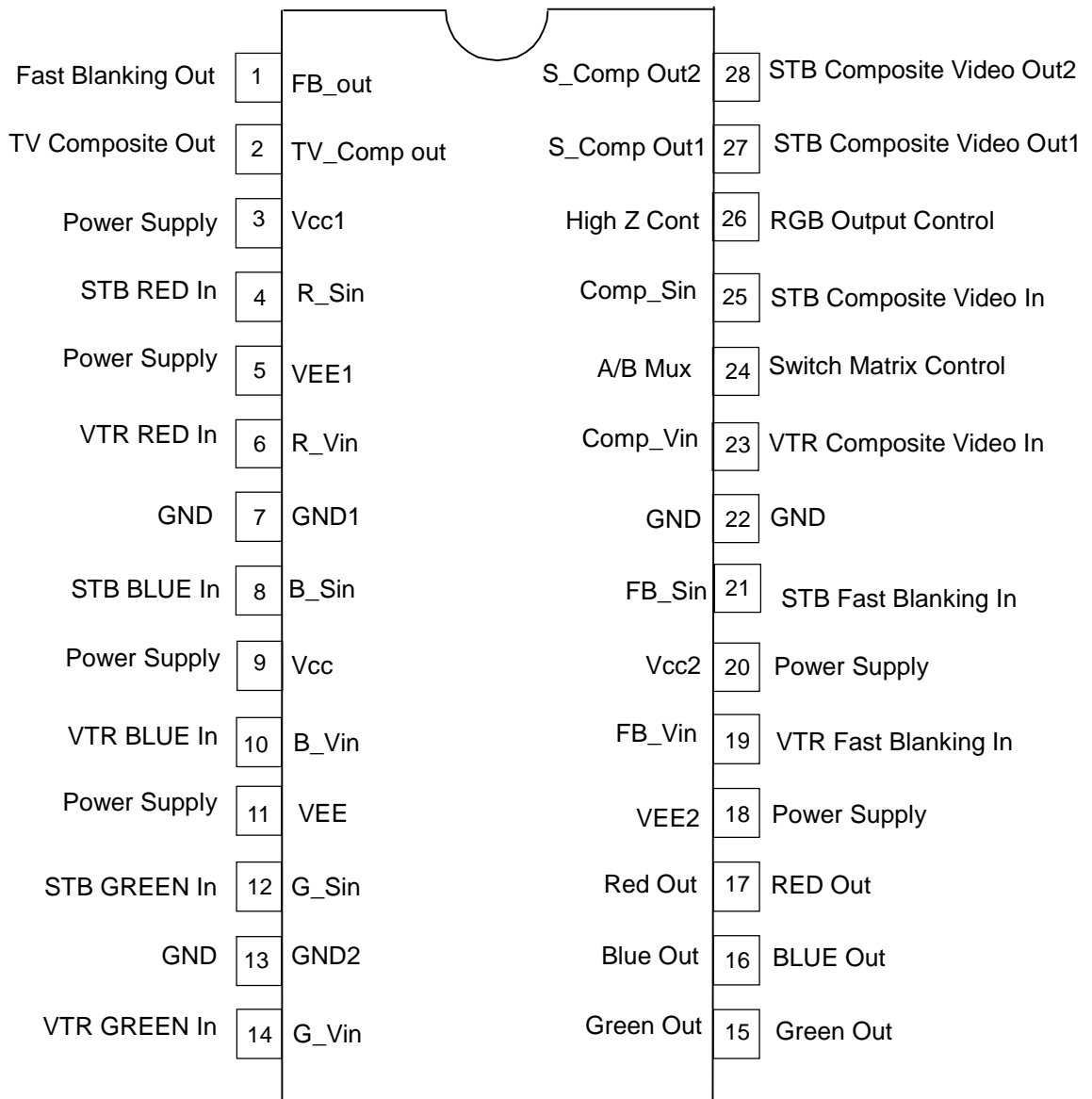

SDIP28

■ Pin Configuration (SDMP30)

Fast Blanking Out	1	FB_out	S_Comp Out2	30	STB Composite Video Out1
TV Composite Out	2	TV_Comp out	S_Comp Out1	29	STB Composite Video Out2
Power Supply	3	Vcc1	High Z Cont	28	RGB Output Control
STB RED In	4	R_Sin	Comp_Sin	27	STB Composite Video In
Power Supply1	5	VEE1	A/B Mux	26	Switch Matrix Control
VTR RED In	6	R_Vin	Comp_Vin	25	VTR Composite Video In
GND	7	GND1	GND	24	GND
STB BLUE In	8	B_Sin	FB_Sin	23	STB Fast Blanking In
Power Supply	9	Vcc	Vcc2	22	Power Supply
VTR BLUE In	10	B_Vin	FB_Vin	21	VTR Fast Blanking In
Power Supply	11	VEE	VEE2	20	Power Supply
No Connect	12	NC	NC	19	No Connect
STB GREEN In	13	G_Sin	Red Out	18	RED Out
GND	14	GND2	Blue Out	17	BLUE Out
VTR GREEN In	15	G_Vin	Green Out	16	Green Out

SDMP30

NJM2277

■ Pin Description

Symbol	Pin No.		I/O Type	Equivalent Circuit	Function
	SDIP28	SDMP30			
FB_out	1	1	O		Fast Blanking Output
TV_Comp out	2	2	O		Composite Video Signal Output
Vcc1	3	3	—	—	Vcc
R_Sin	4	4	I		RGB Signal Input CVBS/Y/C Signal Input

Symbol	Pin No.		I/O Type	Equivalent Circuit	Function
	SDIP28	SDMP30			
VEE1	5	5	—	—	VEE
R_Vin	6	6	I		RGB Signal Input CVBS/Y/C Signal Input
GND1	7	7	—	—	0
B_Sin	8	8	I		RGB Signal Input CVBS/Y/C Signal Input

NJM2277

Symbol	Pin No.		I/O Type	Equivalent Circuit	Function
	SDIP28	SDMP30			
Vcc	9	9	—	—	Vcc
B_Vin	10	10	I		RGB Signal Input CVBS/Y/C Signal Input
VEE	11	11	—	—	VEE
G_Sin	12	13	I		RGB Signal Input CVBS/Y/C Signal Input

Symbol	Pin No.		I/O Type	Equivalent Circuit	Function
	SDIP28	SDMP30			
GND2	13	14	—	—	0
G_Vin	14	15	I		RGB Signal Input CVBS/Y/C Signal Input
Green Out	15	16	O		Filtered RGB Signal Output
Blue Out	16	17	O		Filtered RGB Signal Output

NJM2277

Symbol	Pin No.		I/O Type	Equivalent Circuit	Function
	SDIP28	SDMP30			
Red Out	17	18	O		Filtered RGB Signal Output
VEE2	18	20	—	—	VEE
FB_Vin	19	21	I		VTR/STB Fast Blanking Input
Vcc2	20	22	—	—	Vcc

Symbol	Pin No.		I/O Type	Equivalent Circuit	Function
	SDIP28	SDMP30			
FB_Sin	21	23	I		VTR/STB Fast Blanking Input
GND	22	24	—	—	0
Comp_Vin	23	25	I		Video Signal Input CVBS/Y/C Signal Input
A/B Mux	24	26	I		Input Channel Selector

NJM2277

Symbol	Pin No.		I/O Type	Equivalent Circuit	Function
	SDIP28	SDMP30			
Comp_Sin	25	27	I		Video Signal Input CVBS/Y/C Signal Input
High_Z Cont	26	28	I		RGB Output Impedance Control "0"= High Impedance "1"= Through
S_Comp Out1	27	29	O		Filtered Video Signal Output
S_Comp Out2	28	30	O		Filtered Video Signal Output

■ABSOLUTE MAXIMUM RATING (Ta=25°C)

PARAMETER	SYMBOL	RATING	UNIT
Supply Voltage	V ⁺	15	V
Power Dissipation	P _D	(SDIP28) 700 (SDMP30) 700	mW
Operating Temperature Range	Topr	-40 to +85	°C
Storage Temperature Range	Tstg	-40 to +125	°C

■ELECTRICAL CHARACTERISTICS (Ta=25°C, Vcc=5.0V,VEE=-5V)

PARAMETER	SYMBOL	TEST CONDITION	MIN.	TYP.	MAX.	UNIT
Operating Voltage	V ⁺		±4.5	±5.0	±5.5	V
Supply Current	I _{cc}	No Signal, No Load	36	46	56	mA

●Video system(Ta=25°C, Vcc=5.0V,VEE=-5V, RL=150Ω unless otherwise specified.)

PARAMETER	SYMBOL	TEST CONDITION	MIN	TYP	MAX	UNIT
Gain	GV	Vin=1.0Vp-p 100KHz S_Comp Out1/2,TV_Comp Out Red/Green/Blue Out	6.0	6.4	6.8	dB
Frequency Response Characteristics	FBW	Vin=1.0Vp-p 5MHz /100KHz All filtered channel	-1.0	0	1.0-	dB
Stop Band Rejection	Fsb	f=100KHz/27MHz, 1Vp-p All filtered channel	-35	-41	-	dB
-3dB Bandwidth	Fc	All filtered channel	-	7.1	-	MHz
RGB Gain matching level	Gm	Gain Matching Between Red/Green/Blue Out	-5	0	5	%
Total Harmonic Distortion	THD	f=1KHz, 1Vp-p input	-	0.1	-	%
Cross talk1	CT1	Vin=4.43MHz/1.0Vp-p One input to any other output	-	-60	-	dB
Cross Talk2	CT2	f=4.43MHz/1Vp-p Mux input to output	-	-60	-	dB
Differential Gain	DG	Vin=1Vp-p, 10step Stairs-signal except FBout	-	0.4	-	%
Differential Phase	DP	Vin=1Vp-p, 10step Stairs-signal except FBout	-	0.4	-	deg
Input Impedance	Rin	All Channel	-	50	-	KΩ
Output Impedance	Ro1	High Z Cont="0" Red/Green/Blue Output	10	20	-	KΩ
Output Impedance	Ro2	High Z Cont="1" Red/Green/Blue Output ,	-	45	-	mΩ
Equivalent Output Capacitance	Co	RGB output, High Z Cont="0"	-	3	-	pF
Group Delay	Tpd	Vin=1Vp-p, 100KHz All filtered Channel	-	70	-	nS

NJM2277

■ ELECTRICAL CHARACTERISTICS (Ta=25°C, V=±5V)

● Fast Blanking (Ta=25°C, Vcc=5.0V, VEE=-5V, RL=150Ω unless otherwise specified.)

PARAMETER	SYMBOL	TEST CONDITION	MIN	TYP	MAX	UNIT
Fast Blanking Output Low Level	FBlow	FB S/Vin=0V	0		0.4	V
Fast Blanking Output High Level	FBhigh	FB S/Vin=2Vp-p	2.0	3.8		V
Fast Blanking Delay	Ftpd	FB S/Vin=2Vp-p 100KHz	-	25	-	nS

● Switch Control (Ta=25°C, Vcc=5.0V, VEE=-5V, RL=150Ω unless otherwise specified.)

PARAMETER	SYMBOL	TEST CONDITION	MIN	TYP	MAX	UNIT
A/B Mux Logic-High level	Vihm		2.0			V
A/B Mux Logic-Low level	Vilm				0.8	V
High Z Control Logic-High level	Vihz		2.0			V
High Z Control Logic-Low level	Vilz				0.8	V

● SWITCH CONTROL TABLE

A/B Mux : Input Channel Selector

Control Signal	OUTPUTS				
	TV Comp Video Out	FB Out	Red Out	Green Out	Blue Out
0*	Comp_Vin	FB_Vin	R_Vin	G_Vin	B_Vin
1	Comp_Sin	FB_Sin	R_Sin	G_Sin	B_Sin

* : Default setting

High Z Cont : RGB Outputs Impedance Control

Control Signal	RGB Outputs Impedance
0*	High Impedance
1	Through

* : Default setting

■ Measurement Circuit (Ta=25°C, Vcc=5V, VEE=-5V)

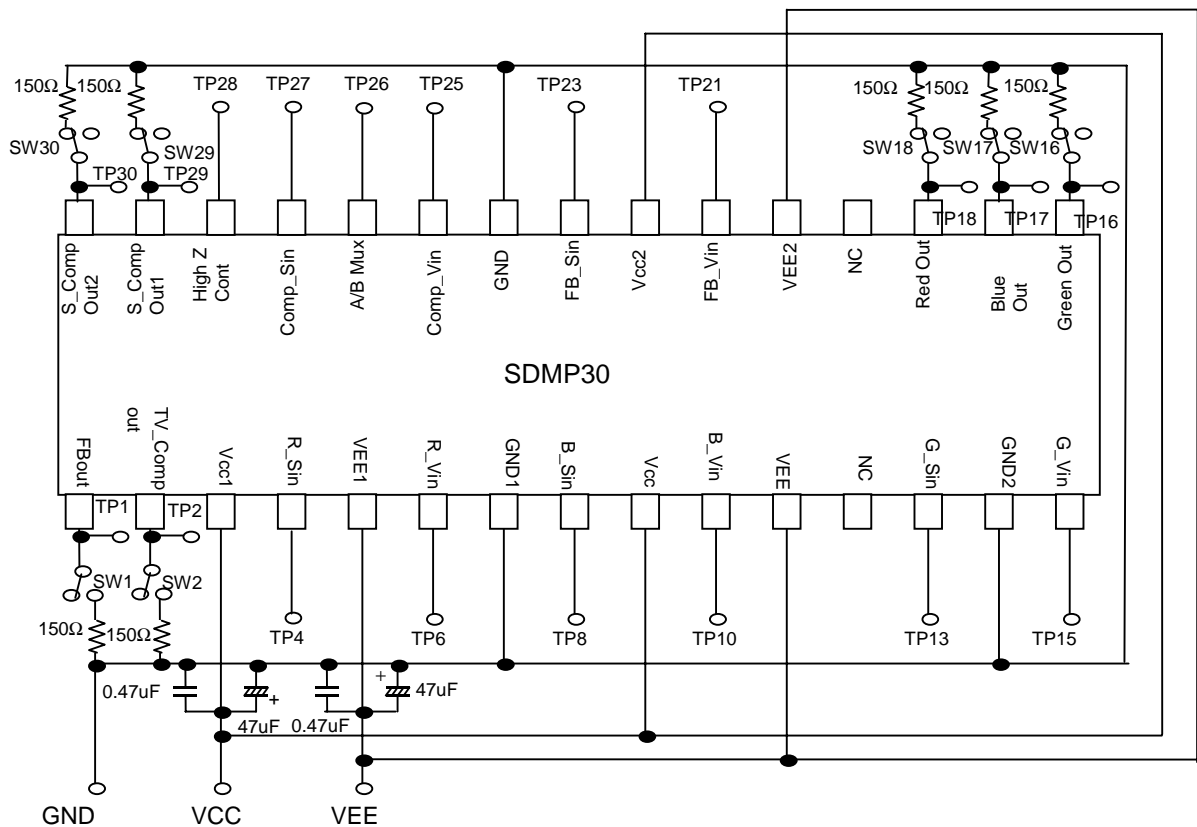
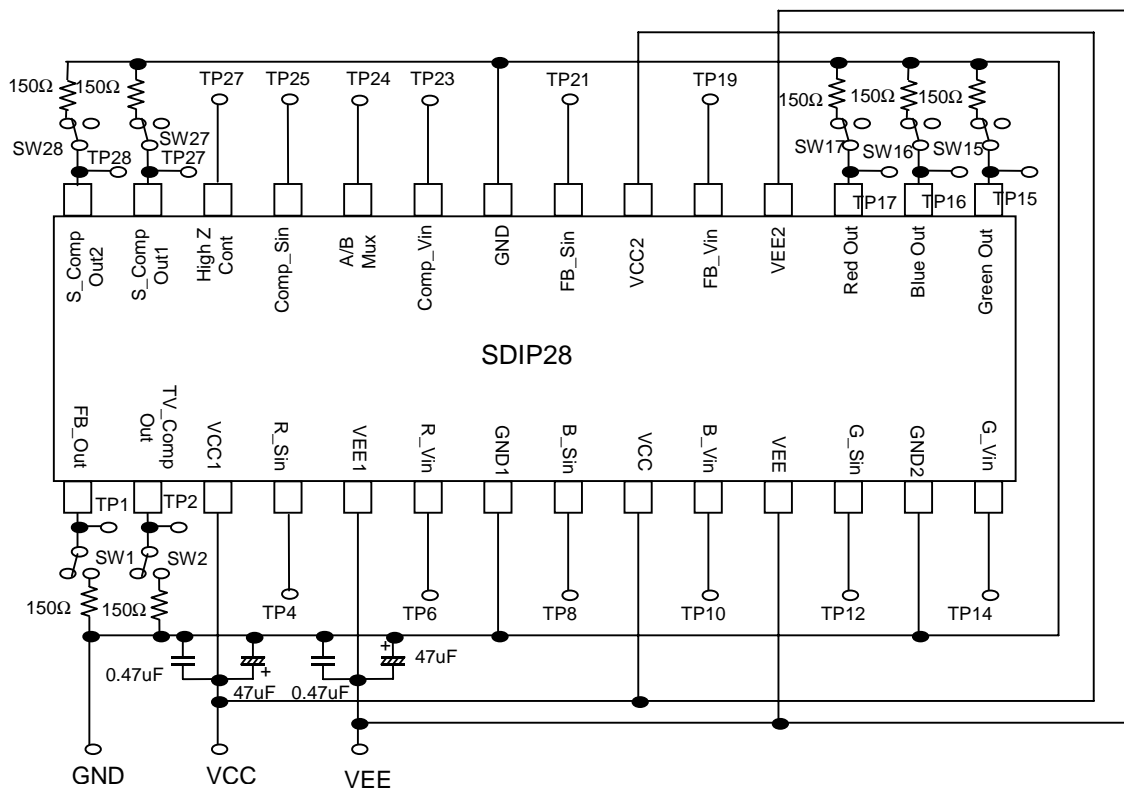

■ Typical Characteristics

Frequency Response
($T_a=25^\circ\text{C}$, $V_{CC}=5\text{V}$, $V_{EE}=-5\text{V}$)

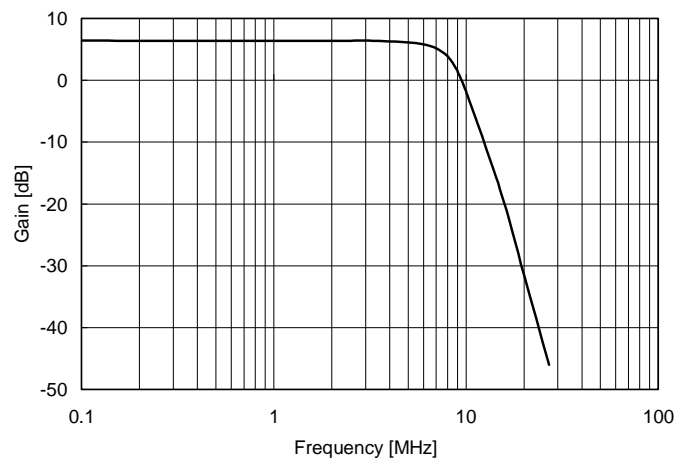

Normalized Frequency Response
($T_a=25^\circ\text{C}$, $V_{CC}=5\text{V}$, $V_{EE}=-5\text{V}$)

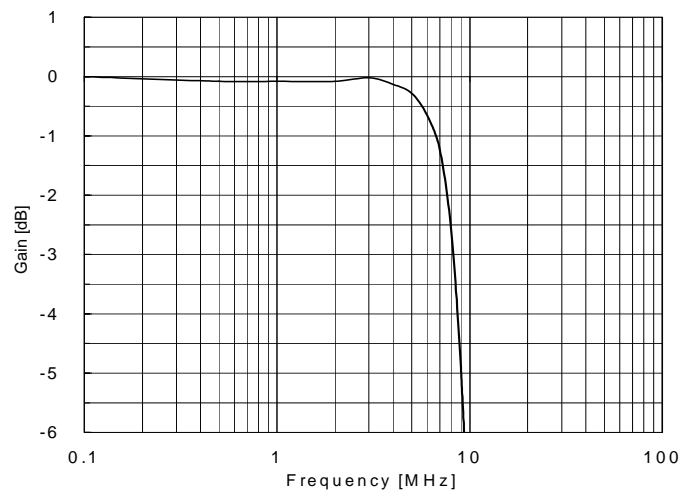

Group Delay
($T_a=25^\circ\text{C}$, $V_{CC}=5\text{V}$, $V_{EE}=-5\text{V}$)

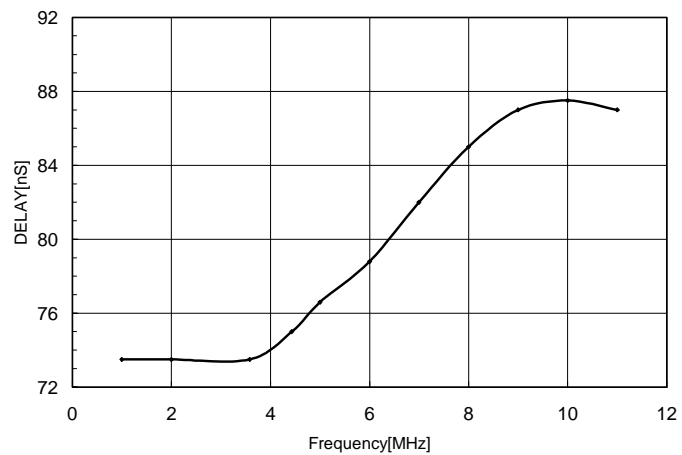

APPLICATION CIRCUIT (SDMP30)

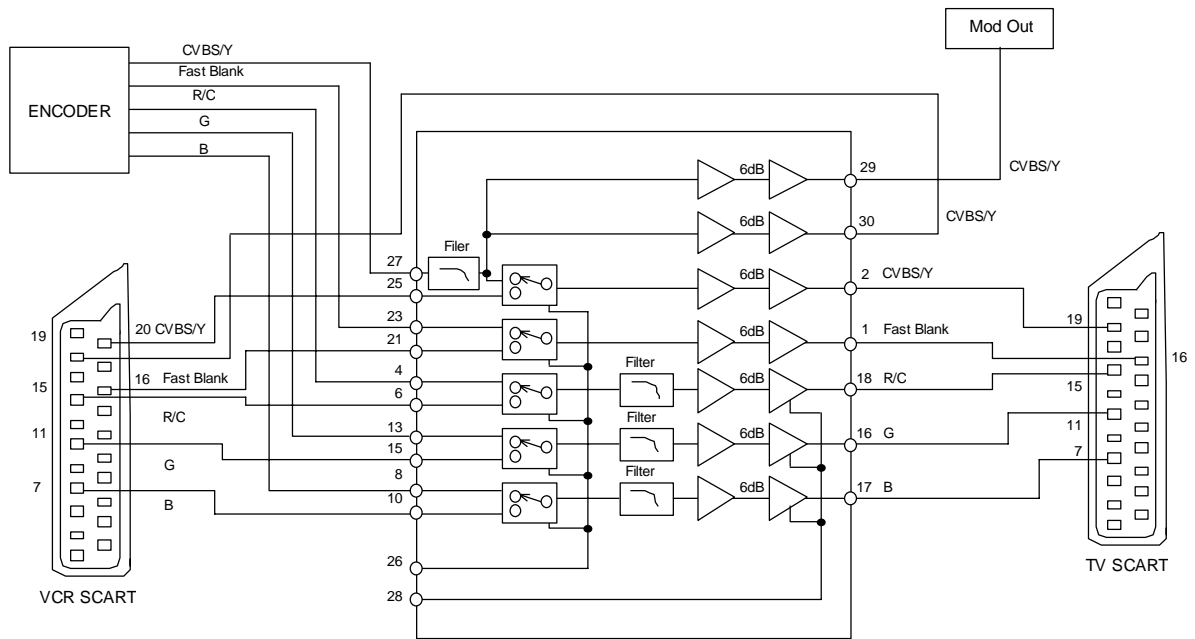

(Note) When there is no offset voltage of input, it is possible to remove the capacitor of 4.7uF of an input.

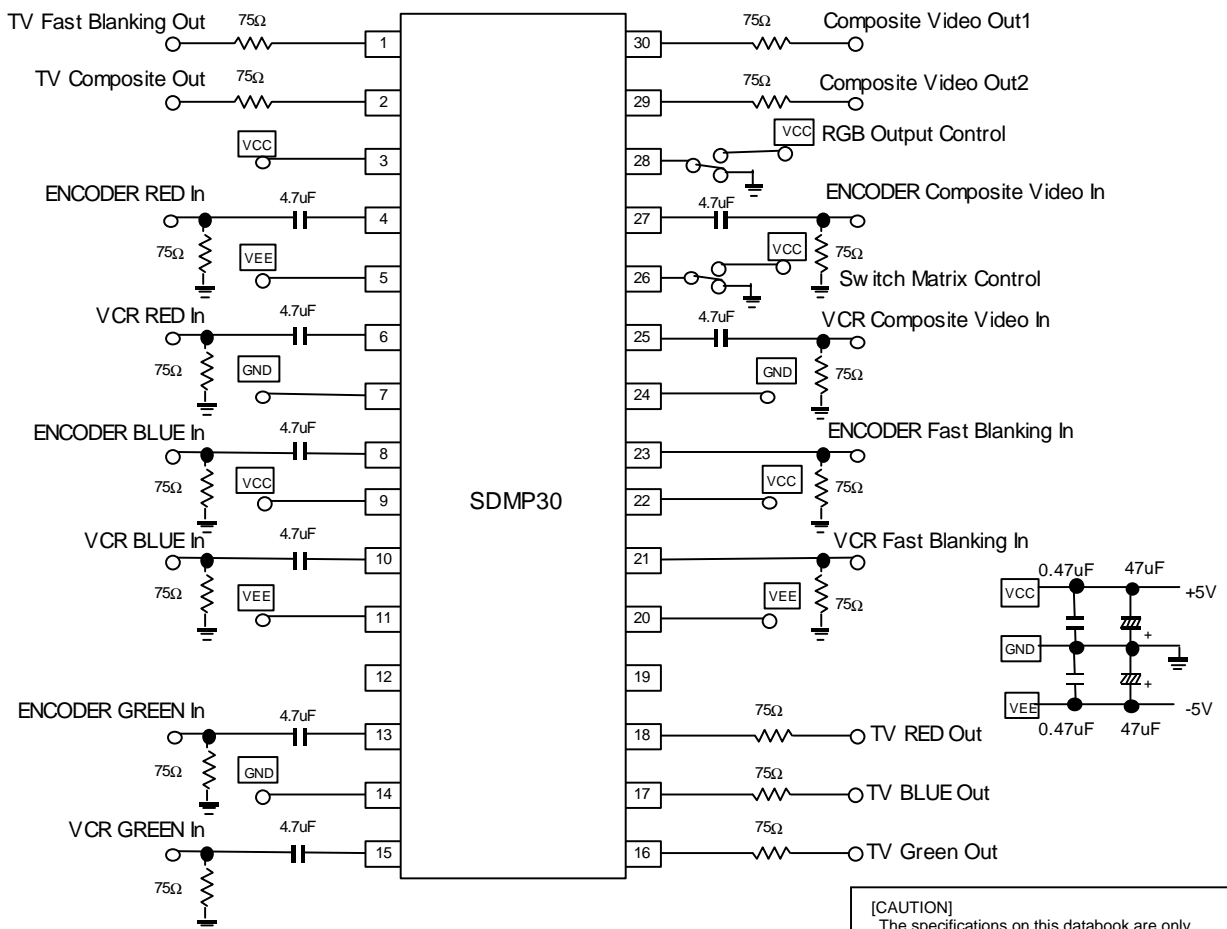

[CAUTION]

The specifications on this databook are only given for information, without any guarantee as regards either mistakes or omissions. The application circuits in this databook are described only to show representative usages of the product and not intended for the guarantee or permission of any right including the industrial rights.