

# MS-N011 VER: 1.0

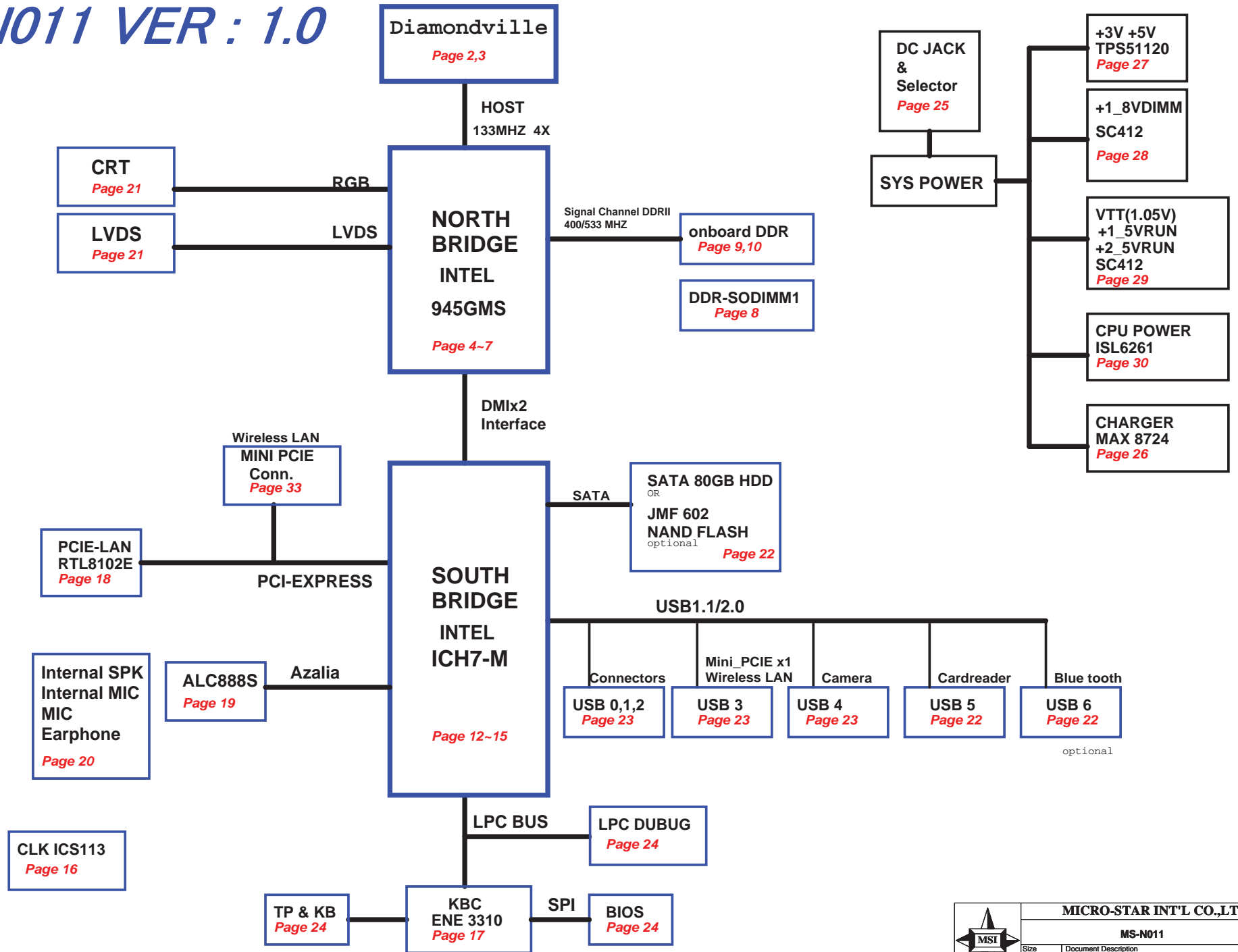

<b>MICRO-STAR INT'L CO.,LTD</b>		
<b>MS-N011</b>		
Size Custom	Document Description <b>BLOCK DIAGRAM</b>	Rev 1.0
Date: Friday, March 28, 2008	Sheet 1	of 39

4 H\_A#(31:3) <<>> H\_A#(31:3)  
 4 H\_RS#(2:0) <<>> H\_RS#(2:0)  
 4 H\_REQ#(4:0) <<>> H\_REQ#(4:0)

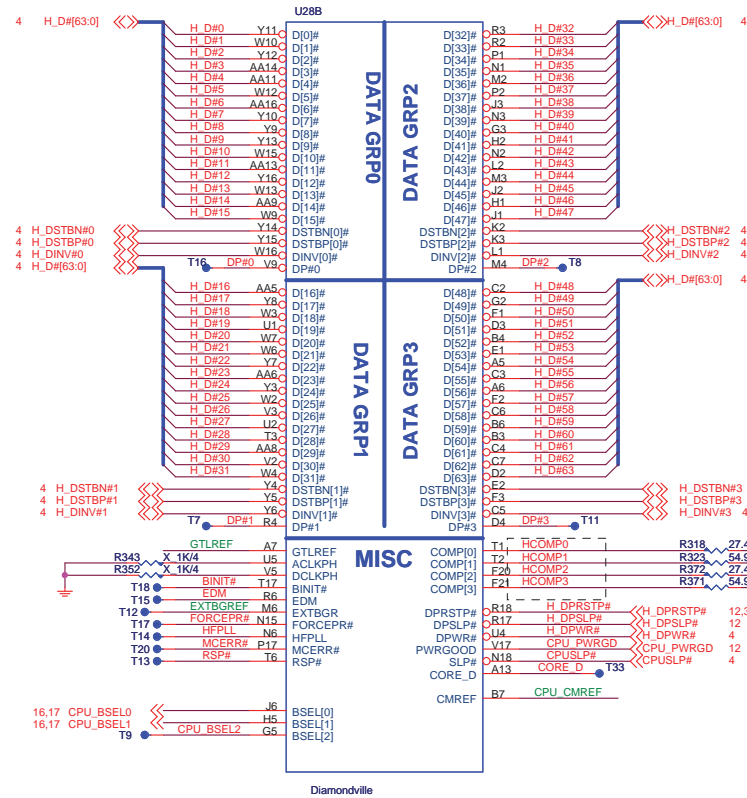
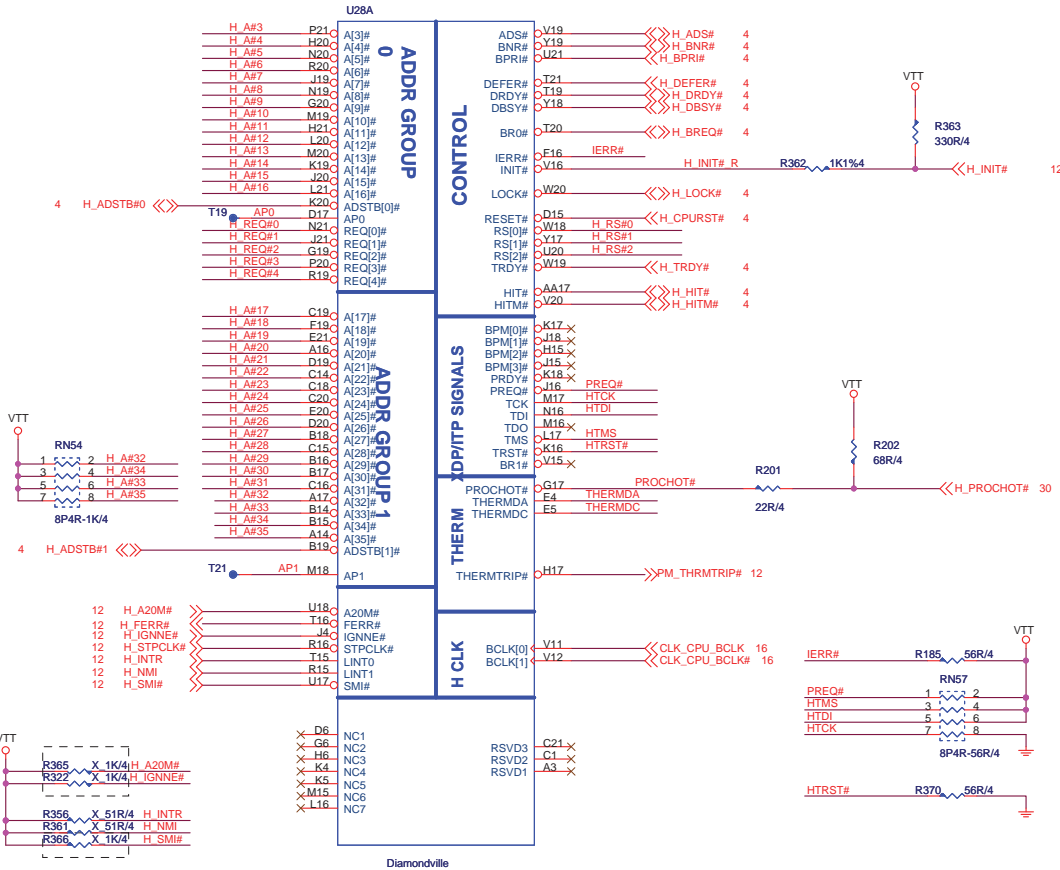

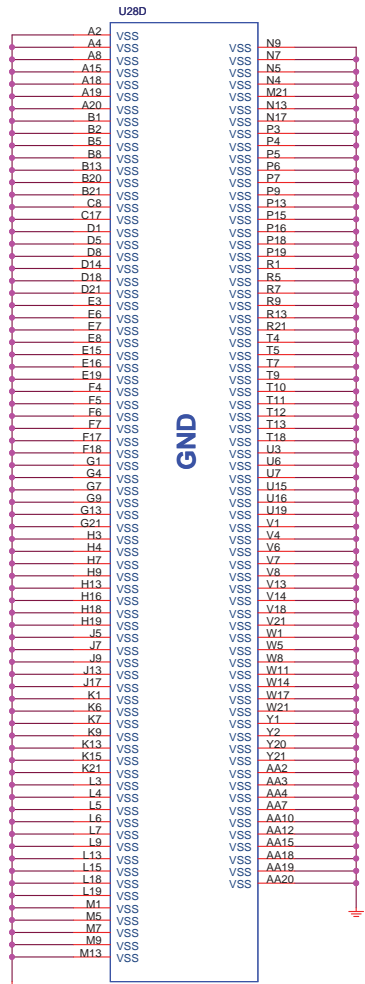

**GND**

**LAYOUT NOTE:**  
Route VCCSENSE and VSSSENSE traces at 27.4ohms with 50 mil spacing.  
Place PU and PD within 1 inch of CPU.

2.5A: before VCC stable  
1.5A: after VCC stable

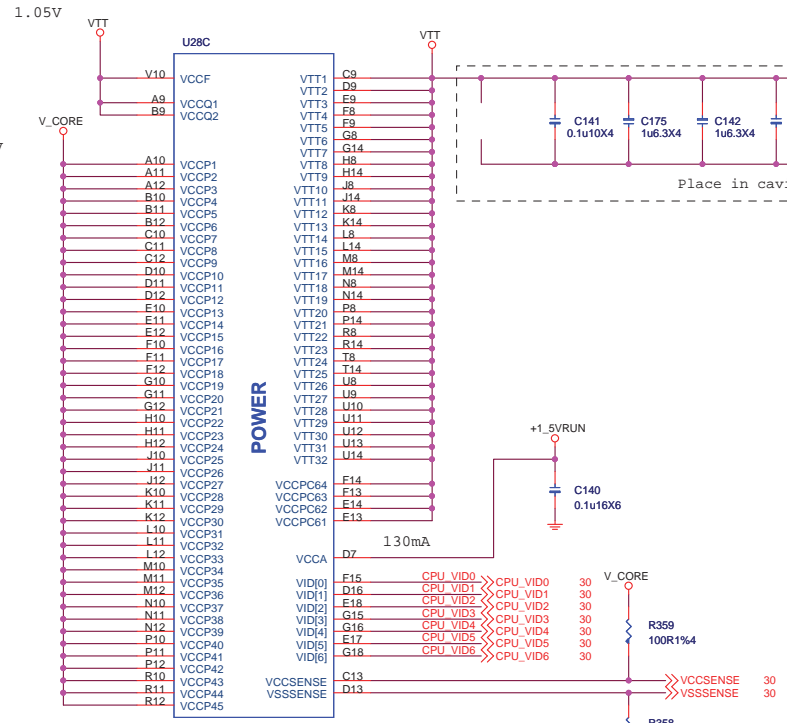

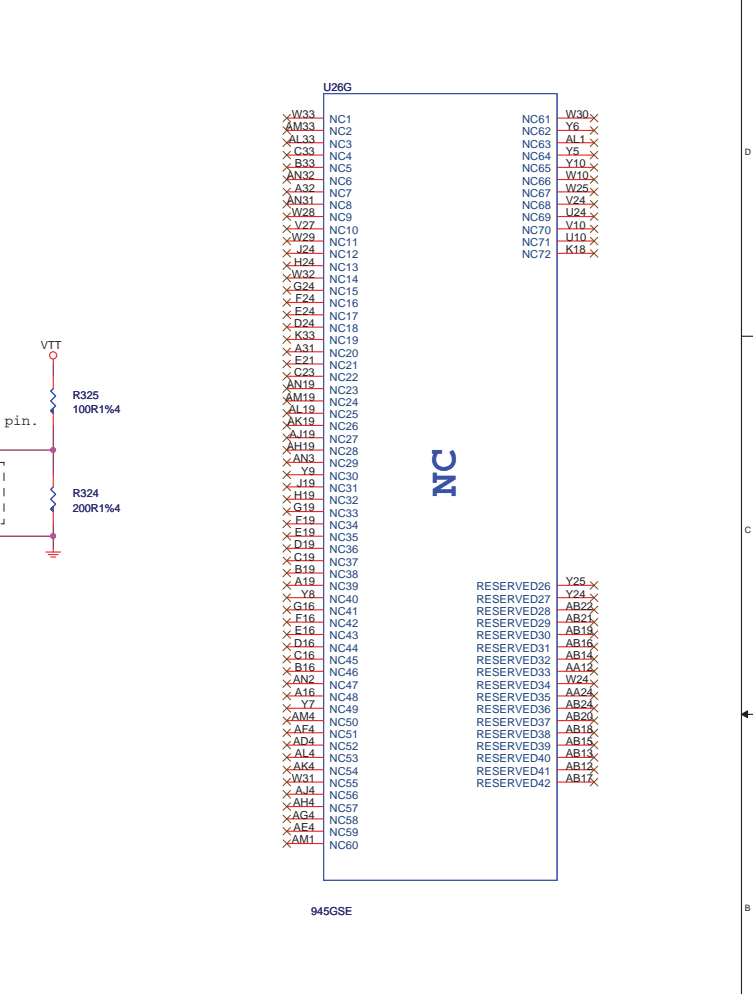
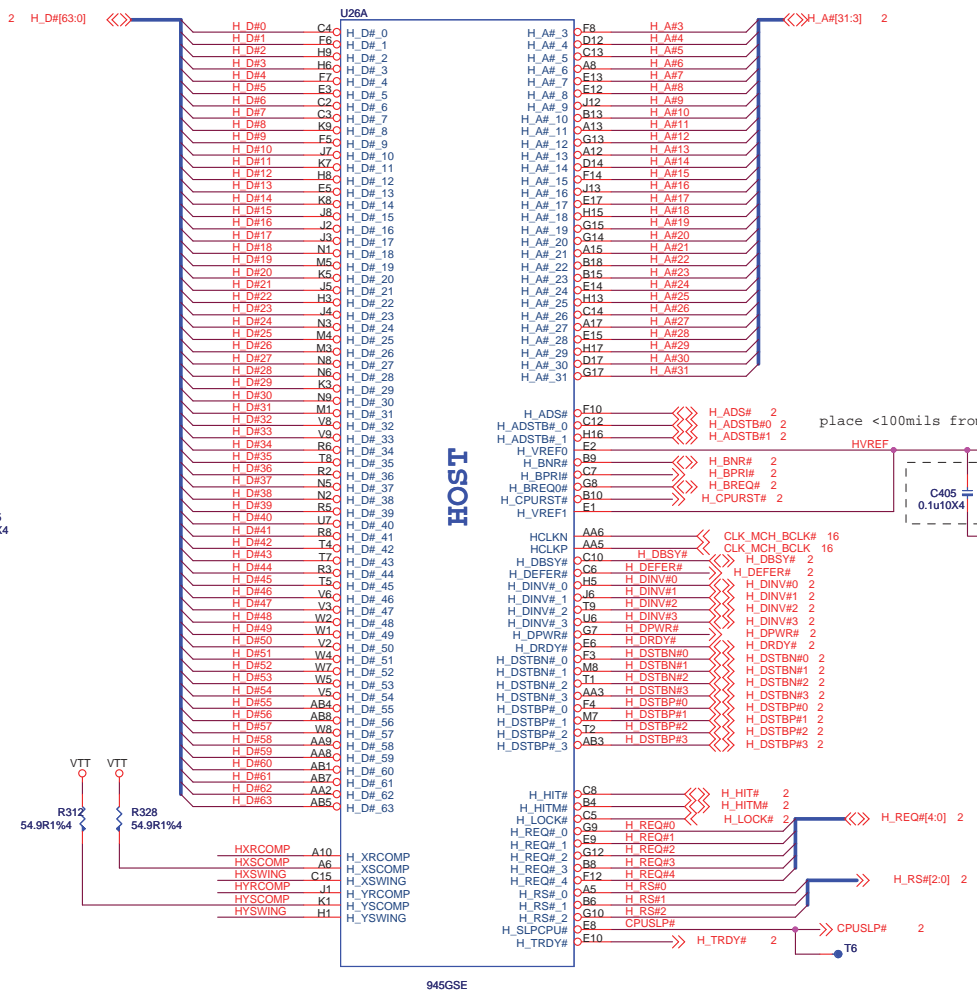
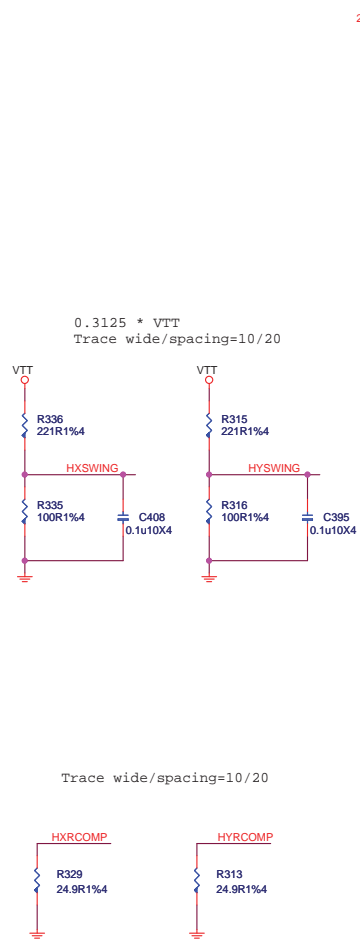

<b>MICRO-STAR INT'L CO.,LTD</b>			
<b>MS-N011</b>			
Size	Document Description	Rev	
Custom	945GMS_HOST	1.0	
Date:	Friday, April 11, 2008	Sheet	4 of 39



8.9 SA\_MD[0.63] <<<

U26C

SA MD0 AC31 SA DO 0  
SA MD1 AB28 SA DO 1  
SA MD2 AE33 SA DO 2  
SA MD3 AF32 SA DO 3  
SA MD4 AC33 SA DO 3  
SA MD5 AB32 SA DO 4  
SA MD6 AB31 SA DO 6  
SA MD7 AE31 SA DO 7  
SA MD8 AH31 SA DO 8  
SA MD9 AK31 SA DO 8  
SA MD10 AL28 SA DO 10  
SA MD11 AK27 SA DO 11  
SA MD12 AH30 SA DO 12  
SA MD13 AL32 SA DO 12  
SA MD14 AJ28 SA DO 14  
SA MD15 AJ27 SA DO 15  
SA MD16 AH32 SA DO 16  
SA MD17 AE31 SA DO 16  
SA MD18 AH27 SA DO 17  
SA MD19 AF28 SA DO 18  
SA MD20 AJ32 SA DO 20  
SA MD21 AC31 SA DO 21  
SA MD22 AG28 SA DO 22  
SA MD23 AG27 SA DO 23  
SA MD24 AN27 SA DO 24  
SA MD25 AM26 SA DO 25  
SA MD26 AJ26 SA DO 26  
SA MD27 AJ25 SA DO 27  
SA MD28 AL27 SA DO 28  
SA MD29 AN26 SA DO 29  
SA MD30 AH25 SA DO 30  
SA MD31 AG26 SA DO 30  
SA MD32 AM12 SA DO 32  
SA MD33 AL11 SA DO 33  
SA MD34 AH9 SA DO 34  
SA MD35 AK9 SA DO 35  
SA MD36 AM11 SA DO 35  
SA MD37 AK11 SA DO 37  
SA MD38 AK8 SA DO 38  
SA MD39 AM8 SA DO 39  
SA MD40 AG9 SA DO 39  
SA MD41 AF9 SA DO 41  
SA MD42 AF8 SA DO 42  
SA MD43 AK6 SA DO 43  
SA MD44 AF7 SA DO 44  
SA MD45 AG11 SA DO 44  
SA MD46 AJ6 SA DO 46  
SA MD47 AH6 SA DO 47  
SA MD48 AN6 SA DO 48  
SA MD49 AM6 SA DO 48  
SA MD50 AK3 SA DO 50  
SA MD51 AL2 SA DO 51  
SA MD52 AM5 SA DO 51  
SA MD53 AL5 SA DO 53  
SA MD54 AJ3 SA DO 54  
SA MD55 AJ2 SA DO 55  
SA MD56 AG2 SA DO 56  
SA MD57 AF3 SA DO 57  
SA MD58 AE7 SA DO 58  
SA MD59 AF6 SA DO 59  
SA MD60 AH5 SA DO 60  
SA MD61 AG3 SA DO 61  
SA MD62 AG5 SA DO 62  
SA MD63 AF5 SA DO 63

DDR2 SYSTEM MEMORY

SA\_BS\_0 AK12 SA\_BS-0 <<< SA\_BS-[0.2] 9,10,11  
SA\_BS\_1 AH11 SA\_BS-1 <<< SA\_BS-[0.2] 9,10,11  
SA\_BS\_2 AG17 SA\_BS-2 <<< SA\_BS-[0.2] 9,10,11

SA\_DM\_0 AB30 SA\_DM0 <<< SA\_DM-[0.7] 8,9  
SA\_DM\_1 AL31 SA\_DM1 <<< SA\_DM-[0.7] 8,9  
SA\_DM\_2 AF30 SA\_DM2 <<< SA\_DM-[0.7] 8,9  
SA\_DM\_3 AK26 SA\_DM3 <<< SA\_DM-[0.7] 8,9  
SA\_DM\_4 AL3 SA\_DM4 <<< SA\_DM-[0.7] 8,9  
SA\_DM\_5 AG7 SA\_DM5 <<< SA\_DM-[0.7] 8,9  
SA\_DM\_6 AK5 SA\_DM6 <<< SA\_DM-[0.7] 8,9  
SA\_DM\_7 AH3 SA\_DM7 <<< SA\_DM-[0.7] 8,9

SA\_DQS\_0 AC28 SA\_DQS0 <<< SA\_DQS-[0.7] 8,9  
SA\_DQS\_1 AJ30 SA\_DQS1 <<< SA\_DQS-[0.7] 8,9  
SA\_DQS\_2 AK33 SA\_DQS2 <<< SA\_DQS-[0.7] 8,9  
SA\_DQS\_3 AL25 SA\_DQS3 <<< SA\_DQS-[0.7] 8,9  
SA\_DQS\_4 AN9 SA\_DQS4 <<< SA\_DQS-[0.7] 8,9  
SA\_DQS\_5 AH8 SA\_DQS5 <<< SA\_DQS-[0.7] 8,9  
SA\_DQS\_6 AM2 SA\_DQS6 <<< SA\_DQS-[0.7] 8,9  
SA\_DQS\_7 AE3 SA\_DQS7 <<< SA\_DQS-[0.7] 8,9

SA\_MA\_0 AJ15 SA\_MA0 <<< SA\_MA-[0.13] 9,10,11  
SA\_MA\_1 AM17 SA\_MA1 <<< SA\_MA-[0.13] 9,10,11  
SA\_MA\_2 AM15 SA\_MA2 <<< SA\_MA-[0.13] 9,10,11  
SA\_MA\_3 AH15 SA\_MA3 <<< SA\_MA-[0.13] 9,10,11  
SA\_MA\_4 AK15 SA\_MA4 <<< SA\_MA-[0.13] 9,10,11  
SA\_MA\_5 AN15 SA\_MA5 <<< SA\_MA-[0.13] 9,10,11  
SA\_MA\_6 AJ18 SA\_MA6 <<< SA\_MA-[0.13] 9,10,11  
SA\_MA\_7 AE19 SA\_MA7 <<< SA\_MA-[0.13] 9,10,11  
SA\_MA\_8 AN17 SA\_MA8 <<< SA\_MA-[0.13] 9,10,11  
SA\_MA\_9 AL17 SA\_MA9 <<< SA\_MA-[0.13] 9,10,11  
SA\_MA\_10 AG16 SA\_MA10 <<< SA\_MA-[0.13] 9,10,11  
SA\_MA\_11 AL18 SA\_MA11 <<< SA\_MA-[0.13] 9,10,11  
SA\_MA\_12 AG18 SA\_MA12 <<< SA\_MA-[0.13] 9,10,11  
SA\_MA\_13 AL14 SA\_MA13 <<< SA\_MA-[0.13] 9,10,11

SA\_CAS# AJ17 SA\_CAS- <<< SA\_CAS- 9,10,11  
SA\_RAS# AK18 SA\_RAS- <<< SA\_RAS- 9,10,11  
SA\_WE# AN28 SA\_RCVENIN- <<< SA\_WE- 9,10,11  
SA\_WE# AM28 SA\_RCVENOUT- <<< SA\_WE- 9,10,11  
SA\_WE# AH17 SA\_WE- <<< SA\_WE- 9,10,11

SB\_BS\_0 AH21 SB\_BS-0 <<< SB\_BS-[0.2] 8,11  
SB\_BS\_1 AJ20 SB\_BS-1 <<< SB\_BS-[0.2] 8,11  
SB\_BS\_2 AE27 SB\_BS-2 <<< SB\_BS-[0.2] 8,11

SB\_MA\_0 AN20 SB\_MA0 <<< SB\_MA-[0.13] 8,11  
SB\_MA\_1 AL21 SB\_MA1 <<< SB\_MA-[0.13] 8,11  
SB\_MA\_2 AK21 SB\_MA2 <<< SB\_MA-[0.13] 8,11  
SB\_MA\_3 AK22 SB\_MA3 <<< SB\_MA-[0.13] 8,11  
SB\_MA\_4 AL22 SB\_MA4 <<< SB\_MA-[0.13] 8,11  
SB\_MA\_5 AH22 SB\_MA5 <<< SB\_MA-[0.13] 8,11  
SB\_MA\_6 AG22 SB\_MA6 <<< SB\_MA-[0.13] 8,11  
SB\_MA\_7 AF21 SB\_MA7 <<< SB\_MA-[0.13] 8,11  
SB\_MA\_8 AM21 SB\_MA8 <<< SB\_MA-[0.13] 8,11  
SB\_MA\_9 AE21 SB\_MA9 <<< SB\_MA-[0.13] 8,11  
SB\_MA\_10 AL20 SB\_MA10 <<< SB\_MA-[0.13] 8,11  
SB\_MA\_11 AE22 SB\_MA11 <<< SB\_MA-[0.13] 8,11  
SB\_MA\_12 AE26 SB\_MA12 <<< SB\_MA-[0.13] 8,11  
SB\_MA\_13 AE20 SB\_MA13 <<< SB\_MA-[0.13] 8,11

945GSE

8.11 SB\_CAS- <<< SB\_CAS- AG19  
8.11 SB\_RAS- <<< SB\_RAS- AG24  
8.11 SB\_WE- <<< SB\_WE- AG20

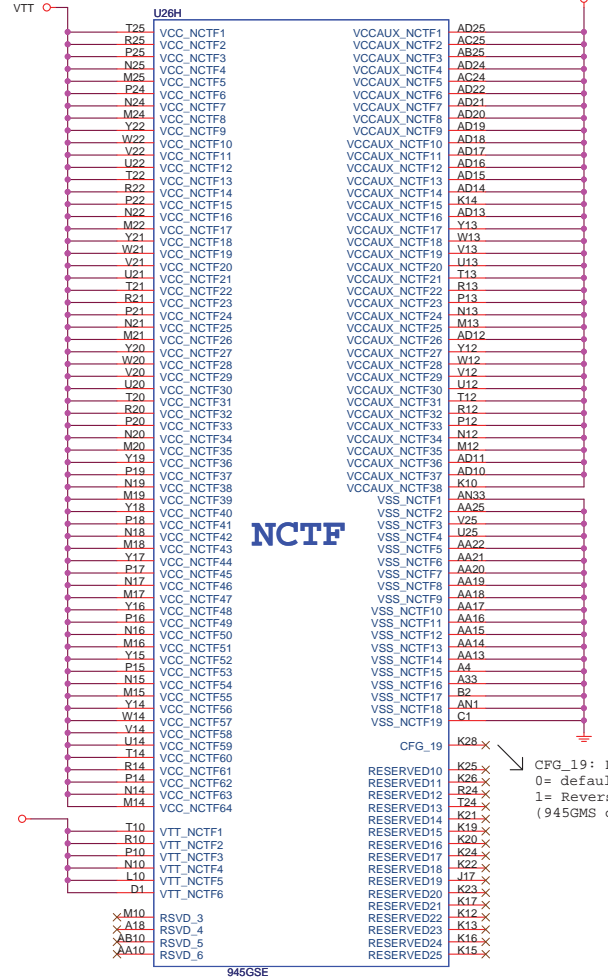

NCTF

CFG\_19: DMI Lane Reversal  
0= default (internal pull-down)  
1= Reversal Lanes  
(945GMS does not support)

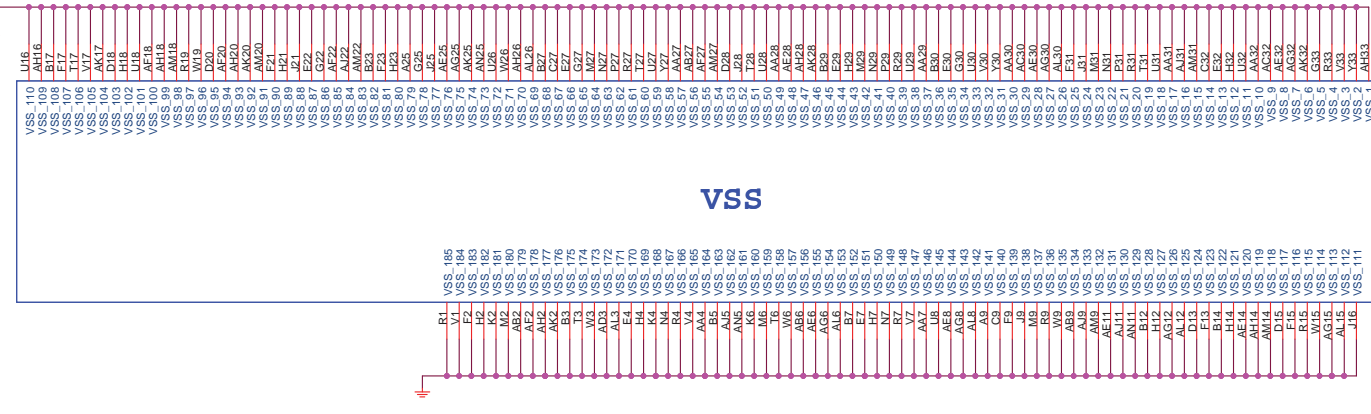

MICRO-STAR INT'L CO.,LTD

MS-N011

Size Custom Document Description 945GMS\_DDR Rev 1.0

Date: Friday, April 11, 2008 Sheet 6 of 39



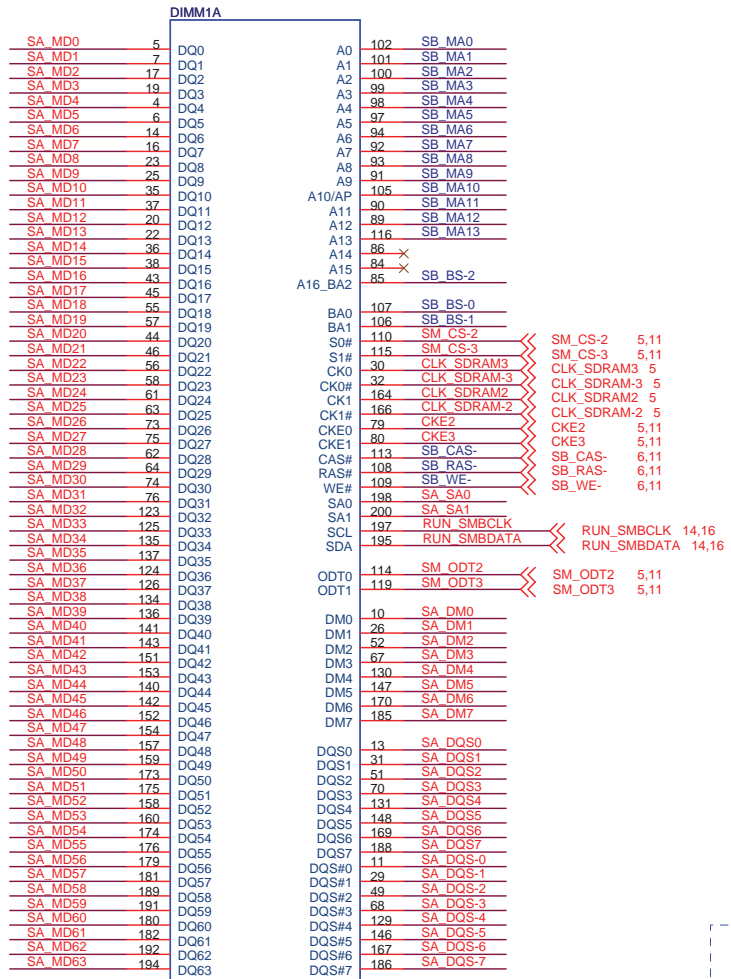

DIMM-200S\_black-1  
**N13-2000220-A10**  
**Bottom**

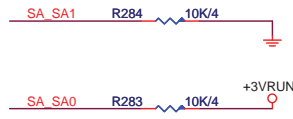
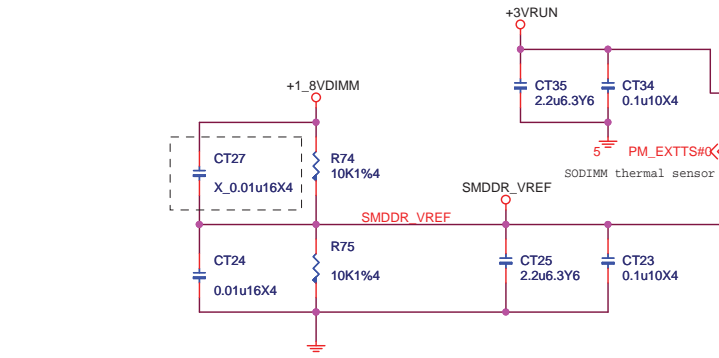
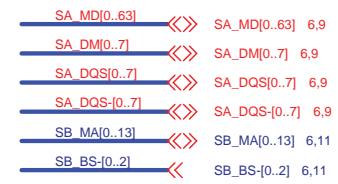

**ADDRESS: 001**  
**0xA2**

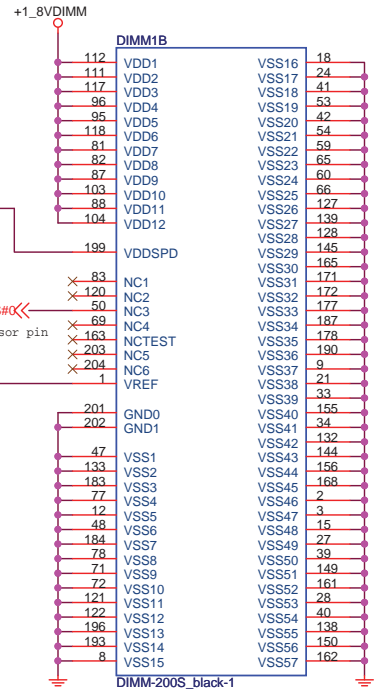
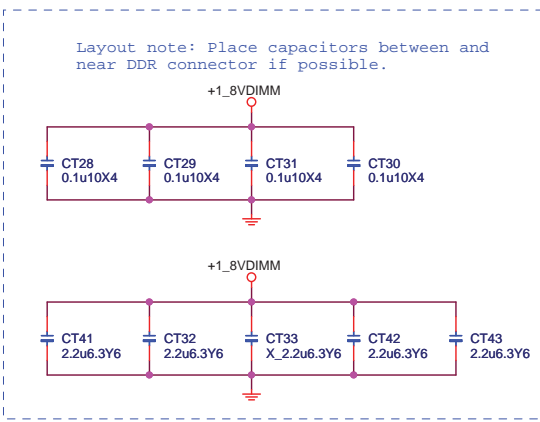

			<b>MICRO-STAR INT'L CO.,LTD</b>	
			<b>MS-N011</b>	
Size B	Document Description		Rev 1.0	
	<b>ONBOARD DDR2 memory</b>			
Date: Friday, April 11, 2008		Sheet 8 of 39		





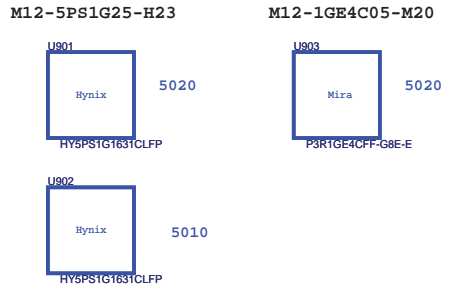
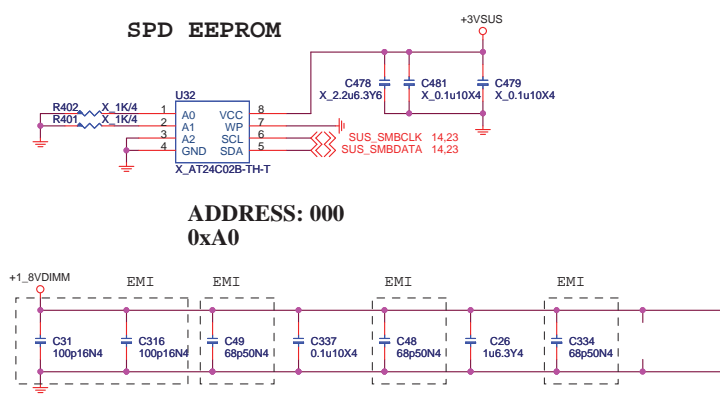
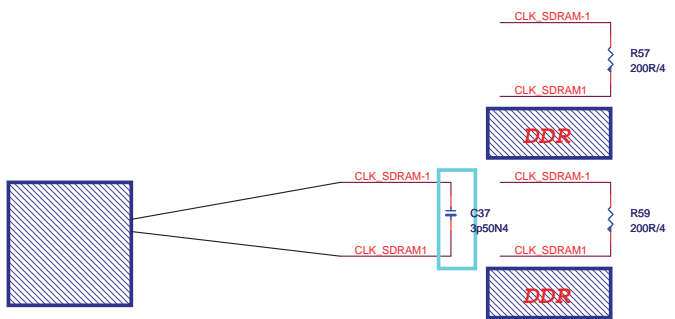
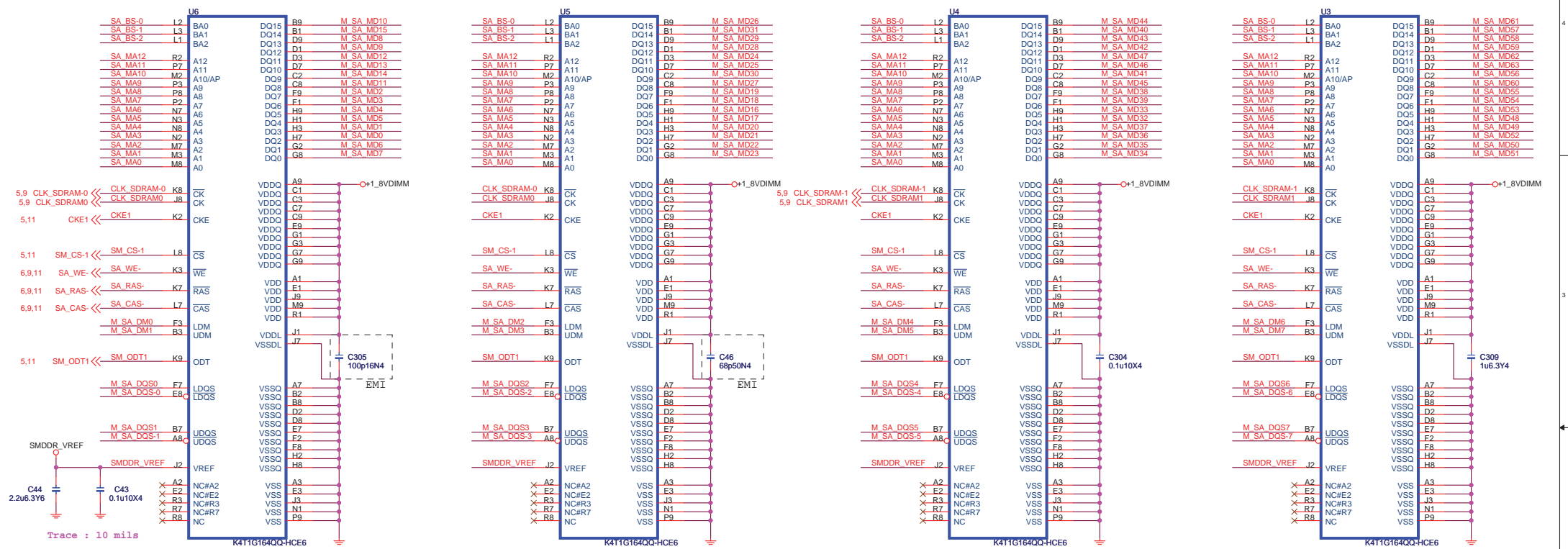

M12-K4T1G05-S02 D-die turn to Q-die next version

- 6.8,9 SA\_MD[0..63] <<> SA MD[0..63]
- 6.8,9 SA\_DQS[0..7] <<> SA DQS[0..7]
- 6.9,11 SA\_MA[0..12] <<> SA MA[0..12]
- 9 M\_SA\_DQS[0..7] <<> M SA DQS[0..7]
- 6.9,11 SA\_BS[0..2] <<> SA BS[0..2]
- 9 M\_SA\_DQS[0..7] <<> M SA DQS[0..7]
- 6.8,9 SA\_DM[0..7] <<> SA DM[0..7]
- 9 M\_SA\_MD[0..63] <<> M SA MD[0..63]
- 6.8,9 SA\_DQS[0..7] <<> SA DQS[0..7]
- 9 M\_SA\_DM[0..7] <<> M SA DM[0..7]

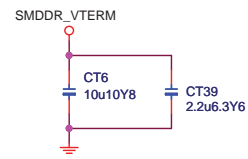
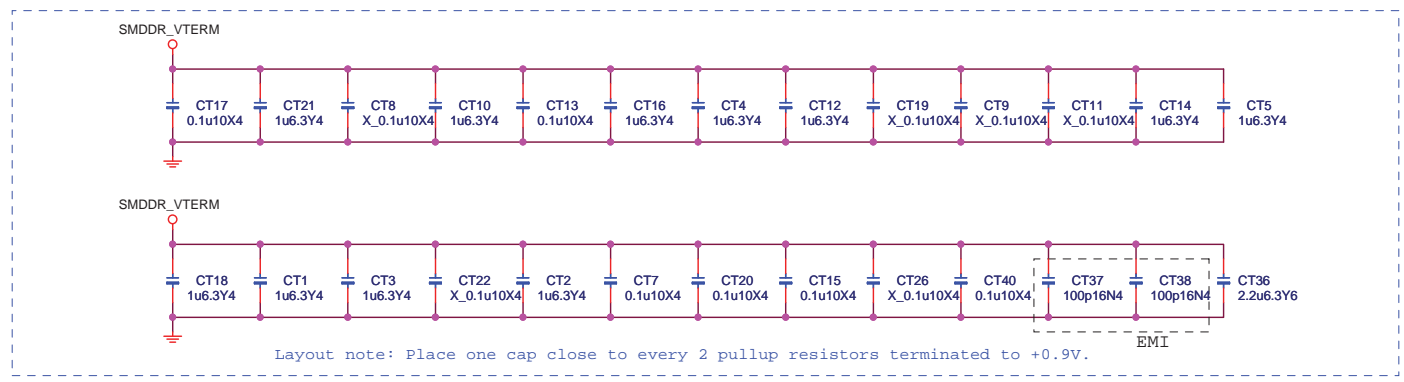
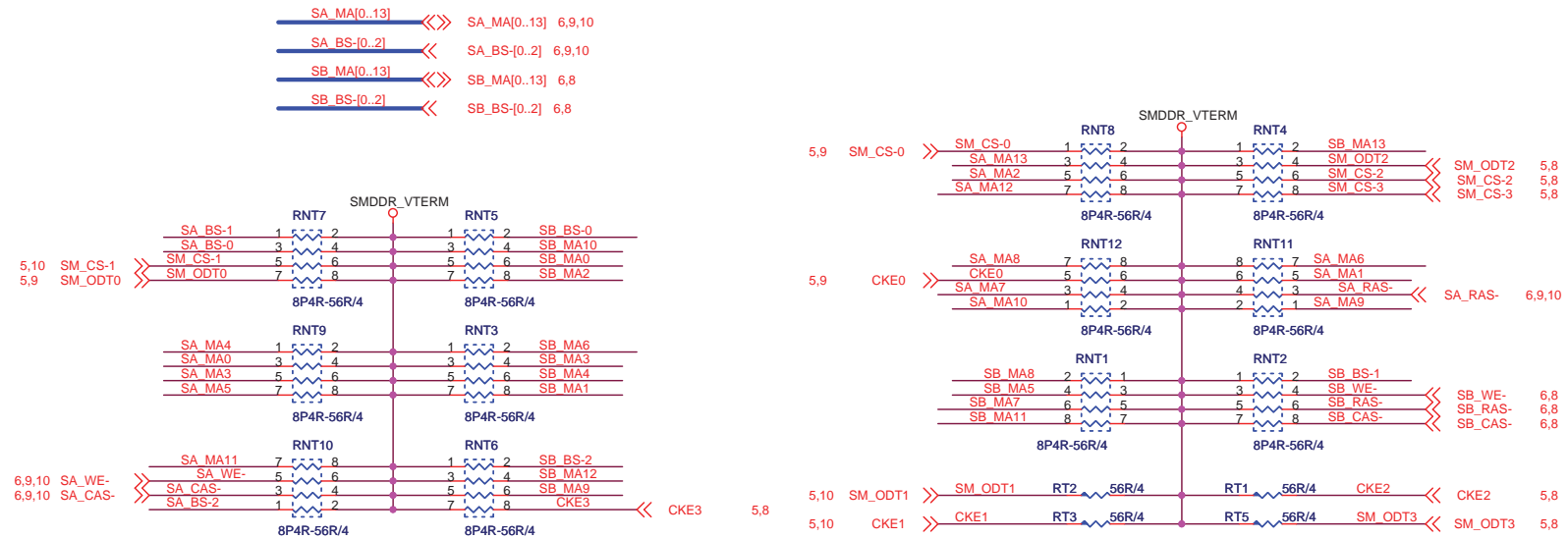

<b>MICRO-STAR INT'L CO.,LTD</b>		
<b>MS-N011</b>		
Size Custom	Document Description <b>DDR2 64*16 BGA B</b>	Rev 1.0
Date: Monday, April 14, 2008		Sheet 10 of 39



			<b>MICRO-STAR INT'L CO.,LTD</b>	
<b>MS-N011</b>				
Size B	Document Description <b>DDR2 Termination</b>			Rev 1.0
Date: Friday, April 11, 2008			Sheet 11 of 39	



BOOT BIOS SELECT STRAPS			
BOOT DEVICE	STRAPS	GNT5#	GNT4#
FWH(LPC default)	11	UNSTUFF	UNSTUFF
PCI	10	UNSTUFF	STUFF
SPI	01	STUFF	UNSTUFF

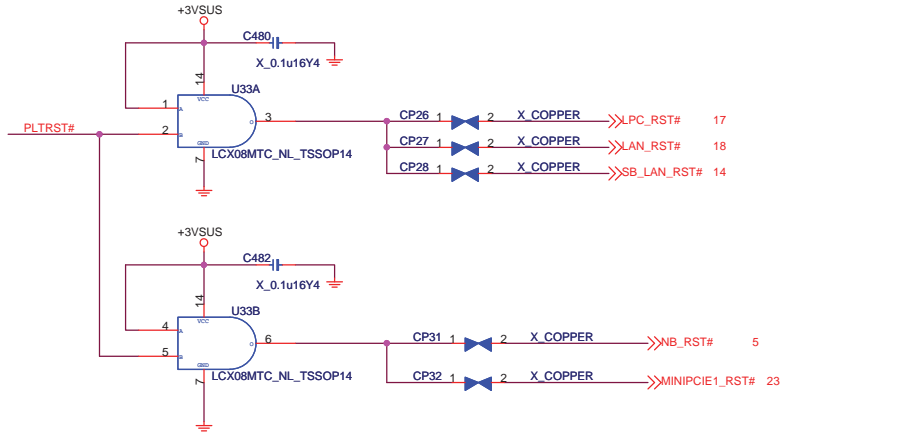
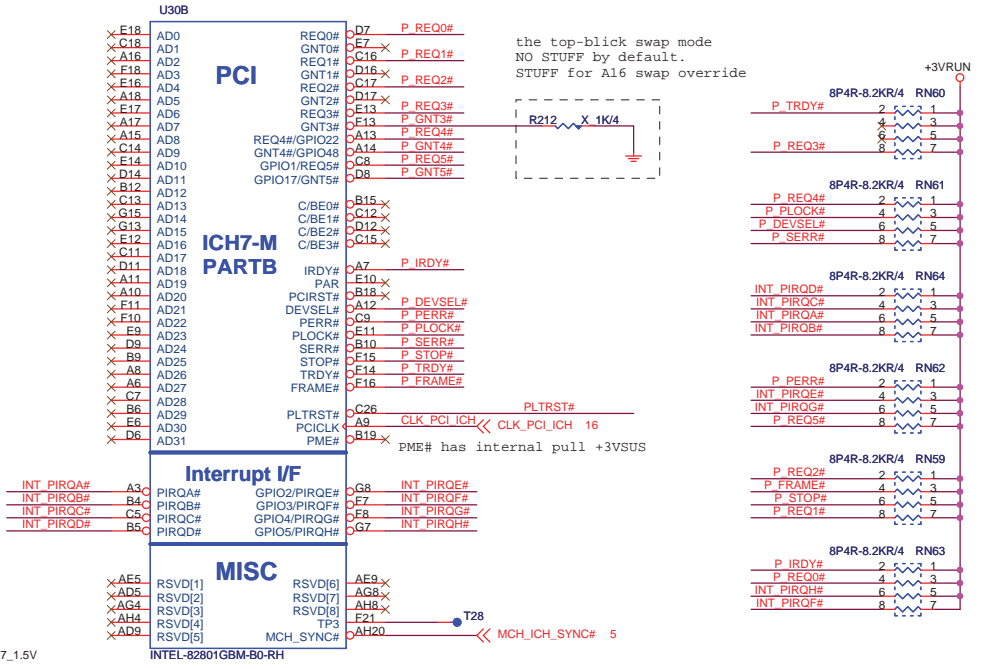
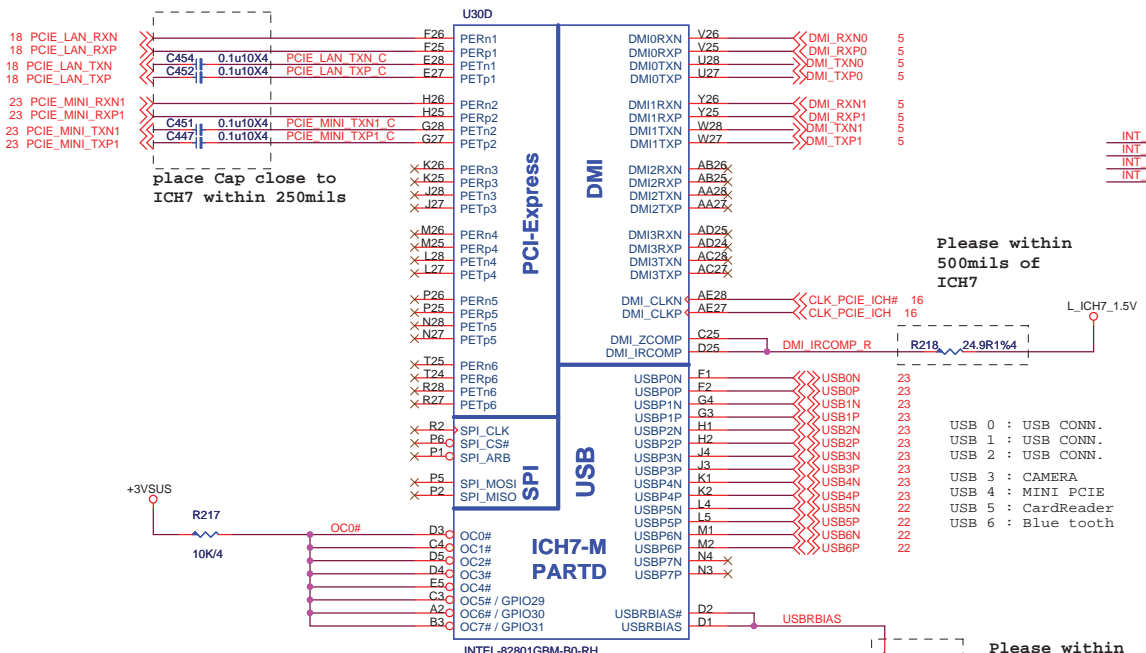

<b>MICRO-STAR INT'L CO.,LTD</b>			
<b>MS-N011</b>			
Size Custom	Document Description		Rev 1.0
<b>ICH7M_PCI, USB, DMI, PCIE</b>			
Date: Friday, April 11, 2008	Sheet 13	of 39	

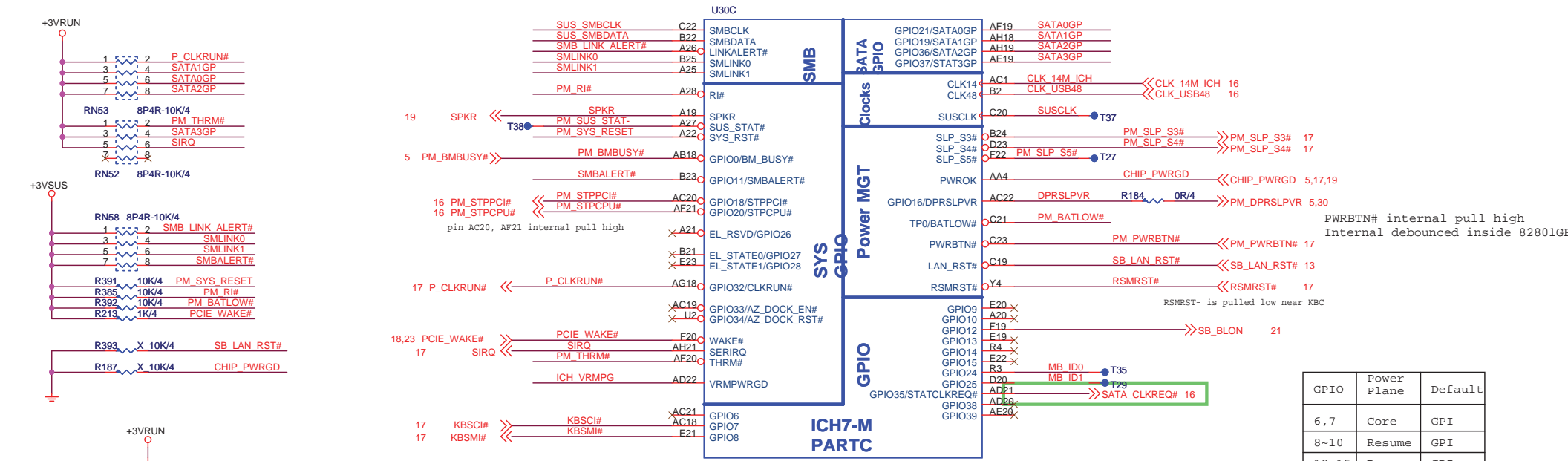

GPIO	Power Plane	Default
6, 7	Core	GPI
8~10	Resume	GPI
12~15	Resume	GPI
24, 25	Resume	GPO
38, 39	Core	GPI

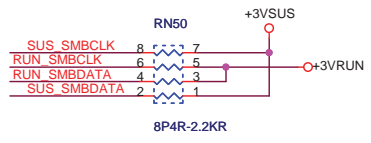
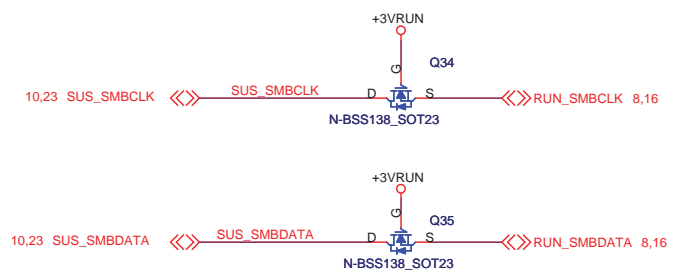
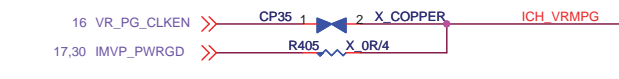
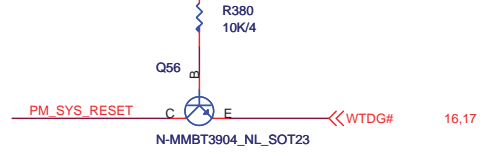

**MICRO-STAR INT'L CO.,LTD**

**MS-N011**

Size Custom	Document Description <b>ICH7M_GPIO, CLK, SM</b>	Rev 1.0
Date: Friday, April 11, 2008		Sheet 14 of 39

**ICH7 M Power**  
**VTT=> 0.954A**  
**+1\_5VRUN=> 1.52A**  
**+3VRUN=> 336mA**  
**+5VRUN=> 6mA**  
**+5VSUS=> 10mA**  
**RTCVCC=> NA**

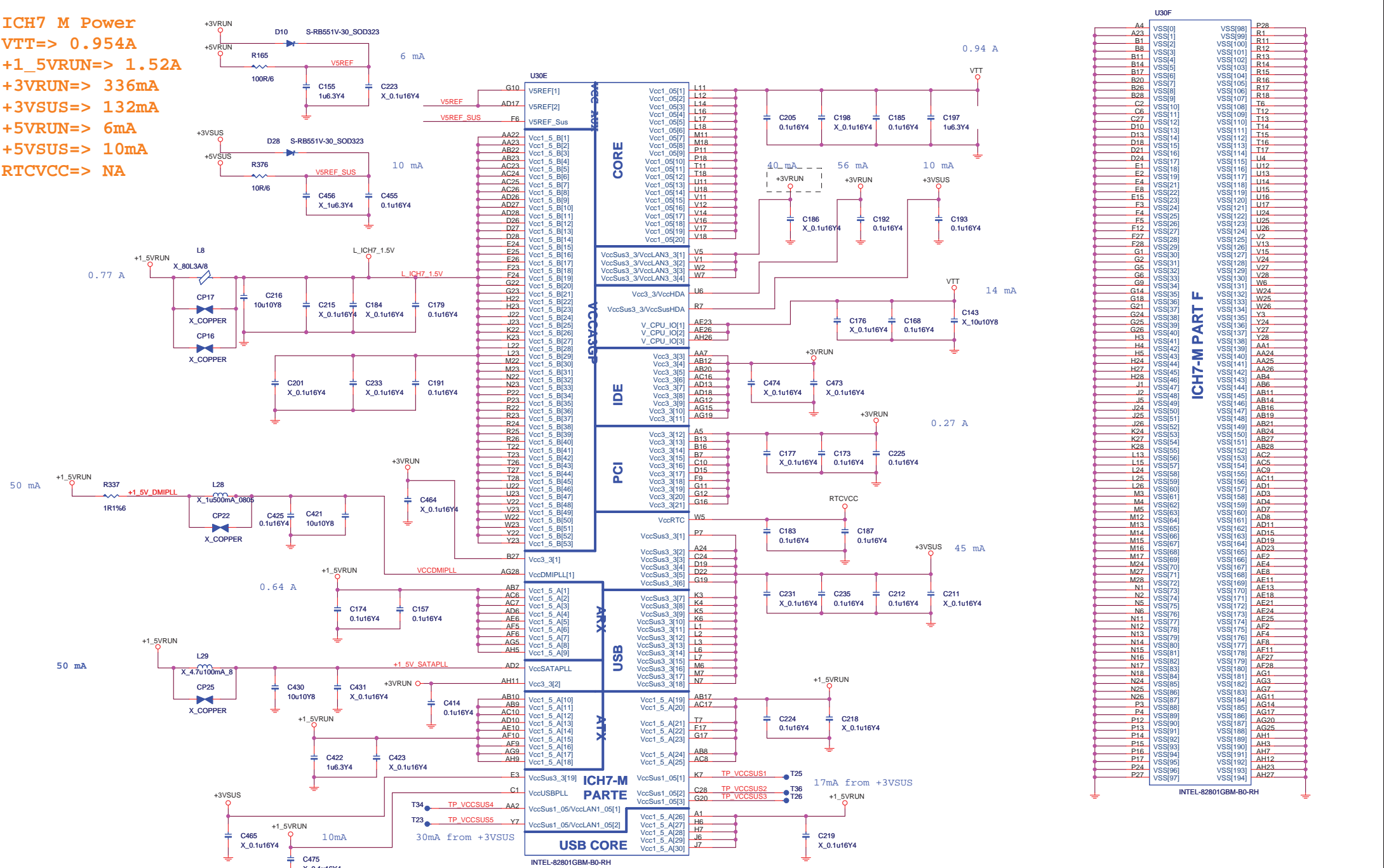

PIN AA2,Y7,K7,C28,G20 : VccSus 1.05V for RTCVCC

		<b>MICRO-STAR INT'L CO.,LTD</b>	
		<b>MS-N011</b>	
Size	Document Description	<b>ICH7M POWER</b>	
Custom			
Date: Friday, April 11, 2008		Sheet	15 of 39

# CLK Gen ICS9LPRS113

## CLOCK GEN STRAPING

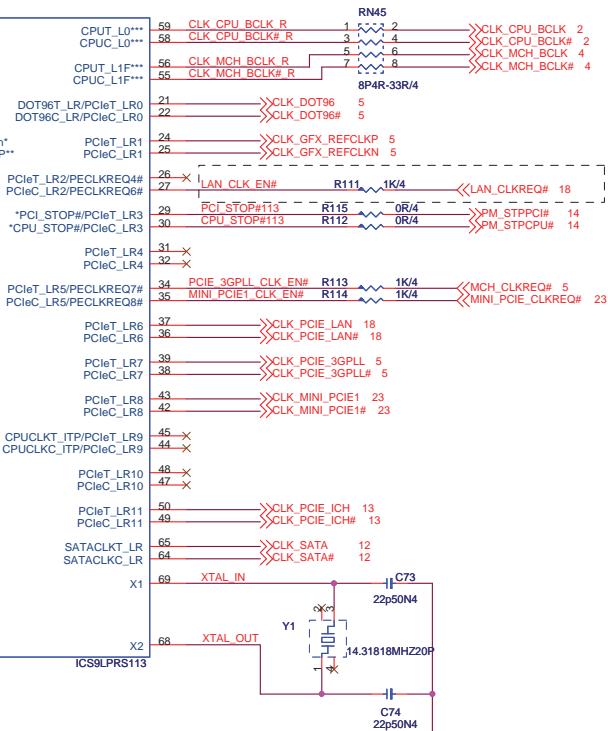
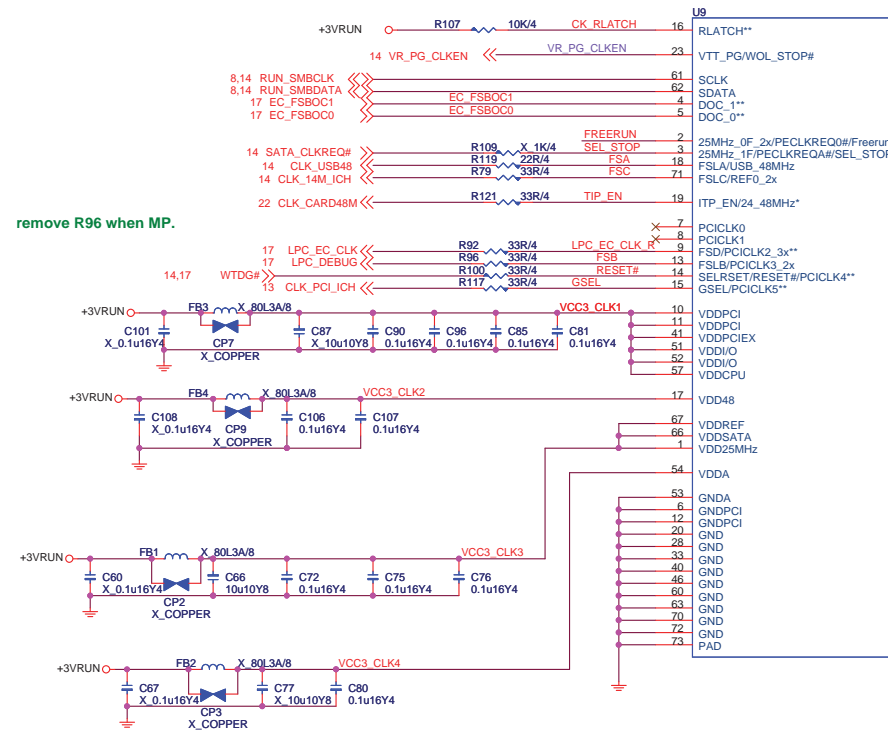

1 => Pin21/22 96MHz  
0 => Pin21/22 100MHz

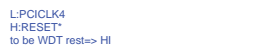

113 TIP\_EN=0 => PCIE9, TIP\_EN=1 => CPU\_ITP

110 TIP\_EN=0 => 48MHz, TIP\_EN=1 => 24MHz



Selects pin 29/830  
1 = PCI\_STOP#/CPU\_STOP#  
0 = PCIE9 CLK output

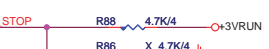

### EMI

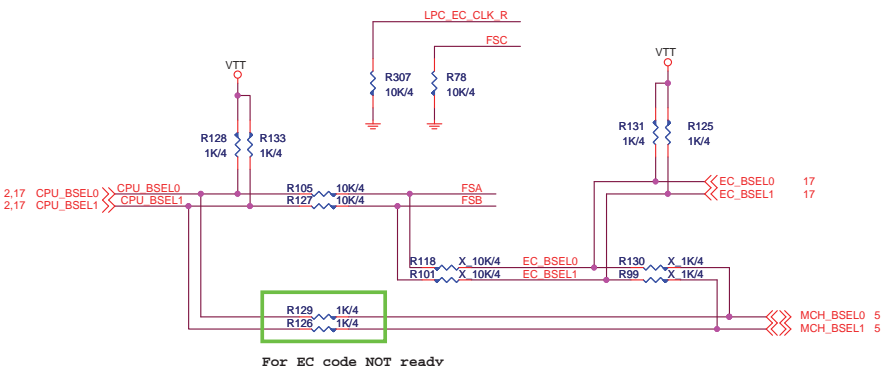
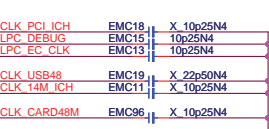

CPU Table

CLK Gen 113

BSEL[2]	BSEL[1]	BSEL[0]	BCLK
L	L	L	100MHZ
L	L	H	133MHZ
L	H	L	RESERVED
L	H	H	166MHZ

BSEL[2]	BSEL[1]	BSEL[0]	BCLK
H	L	H	100MHZ
L	L	H	133MHZ
L	H	L	200MHz
L	H	H	166MHZ

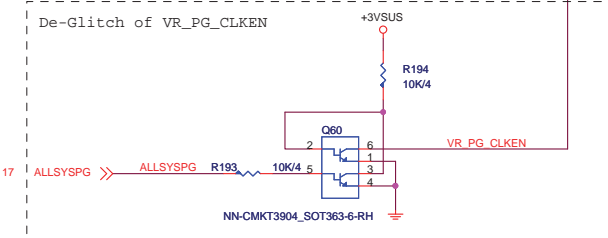

MICRO-STAR INT'L CO.,LTD

MS-N011

Size Custom Document Description CLK\_GEN\_113 Rev 1.0

Date: Friday, April 11, 2008 Sheet 16 of 39





# RTL8102E 10/100M LAN

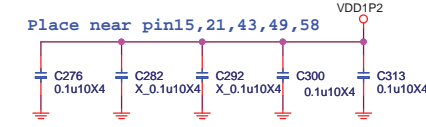
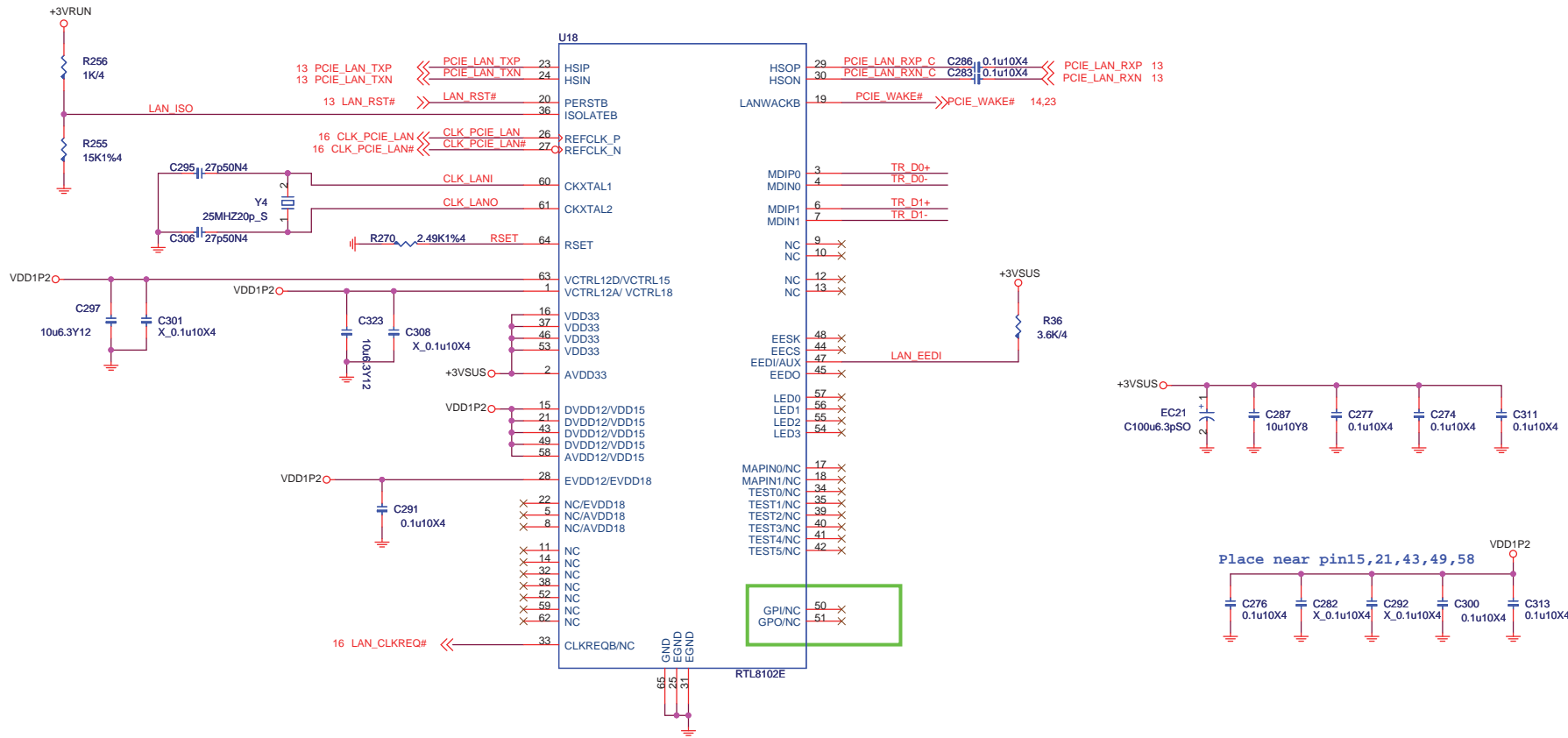

## LAN MAGNETICS

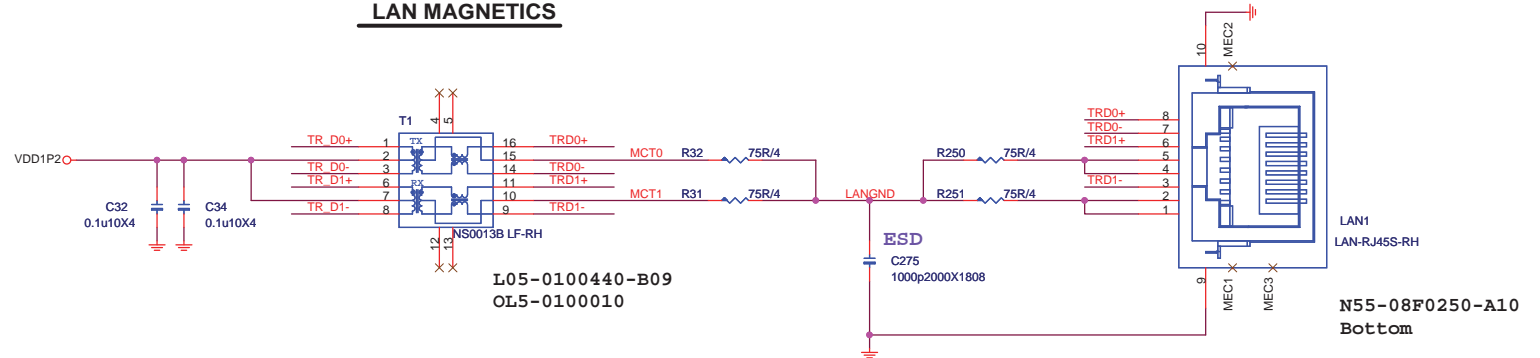

POWER			
BOOT DEVICE	VDD1P2	VDD1P8	VDD33
8101E (378.3mW)	1.5V	1.8V	3.3V
8102E	1.2V	NC	3.3V
365mA			



MICRO-STAR INT'L CO.,LTD		
MS-N011		
Size A3	Document Description LAN_RTL8102E/8101E	Rev 1.0
Date: Friday, April 11, 2008	Sheet 18 of 39	

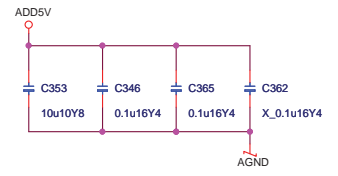
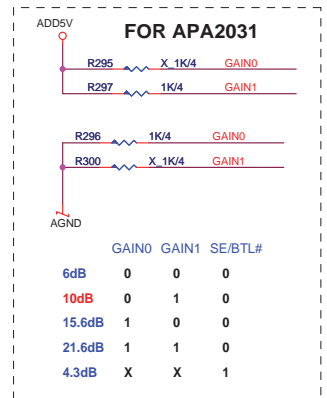
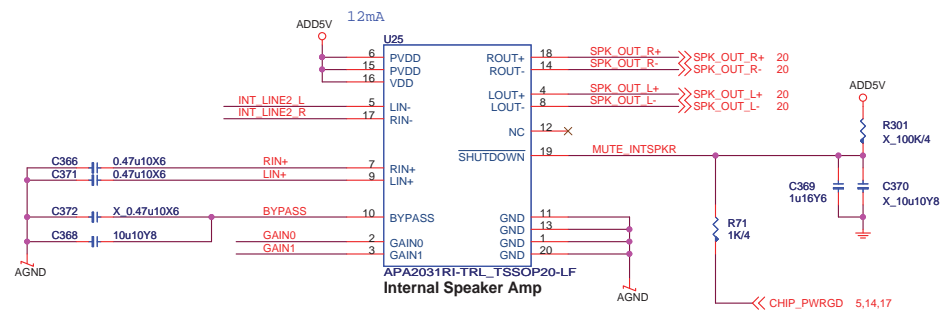
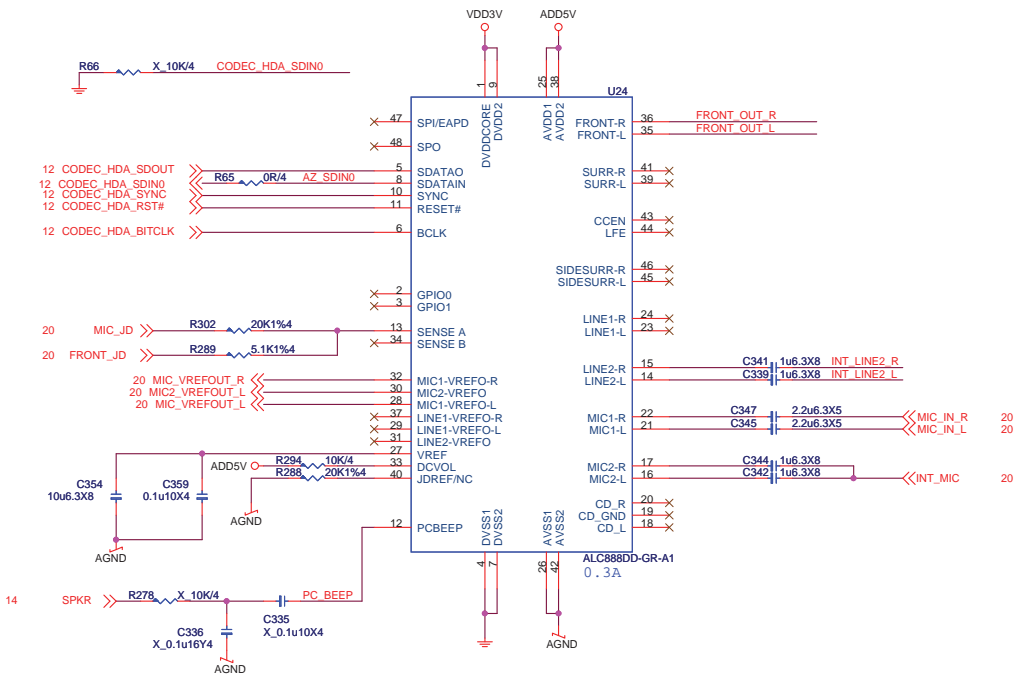

**ANTIPOP CIRCUIT**

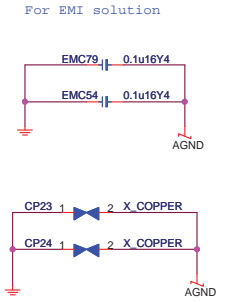
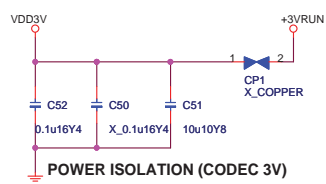
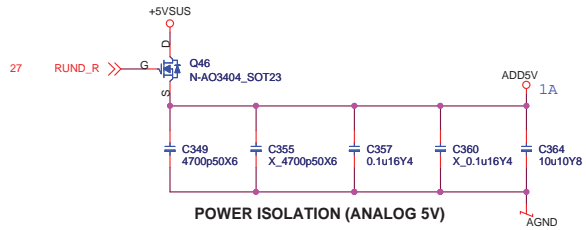
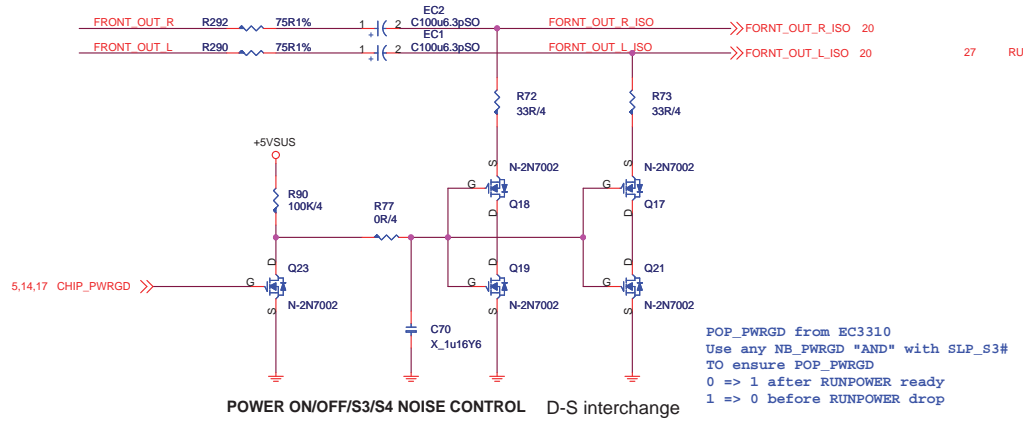

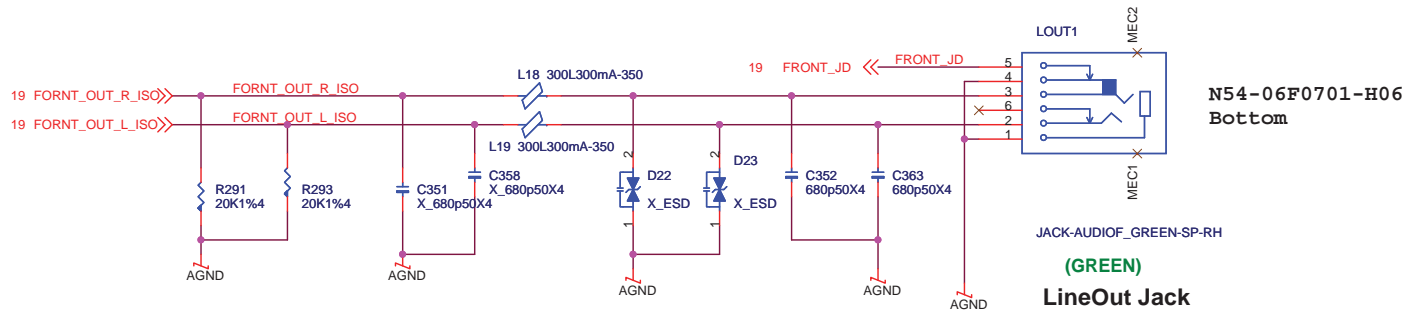
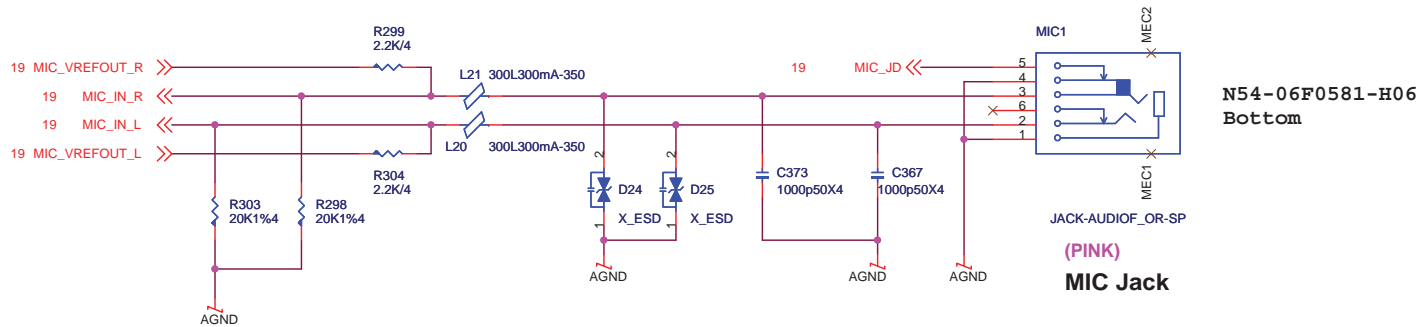
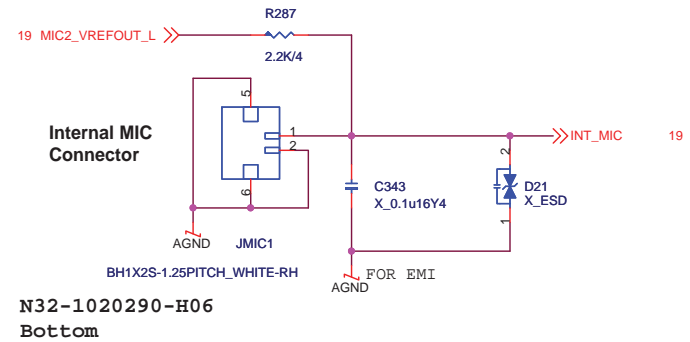
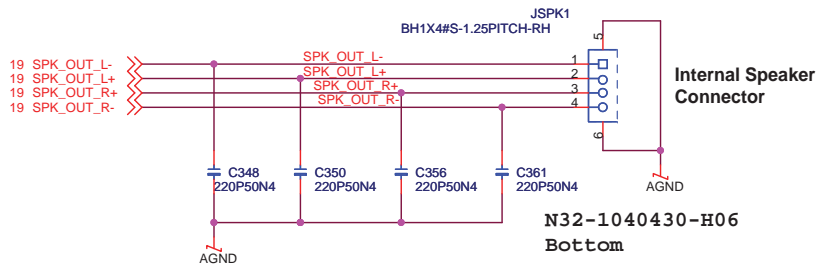

**MICRO-STAR INT'L CO.,LTD**  
**MS-N011**  
 Size Custom Document Description ALIC888S Rev 1.0  
 Date: Friday, April 11, 2008 Sheet 19 of 39

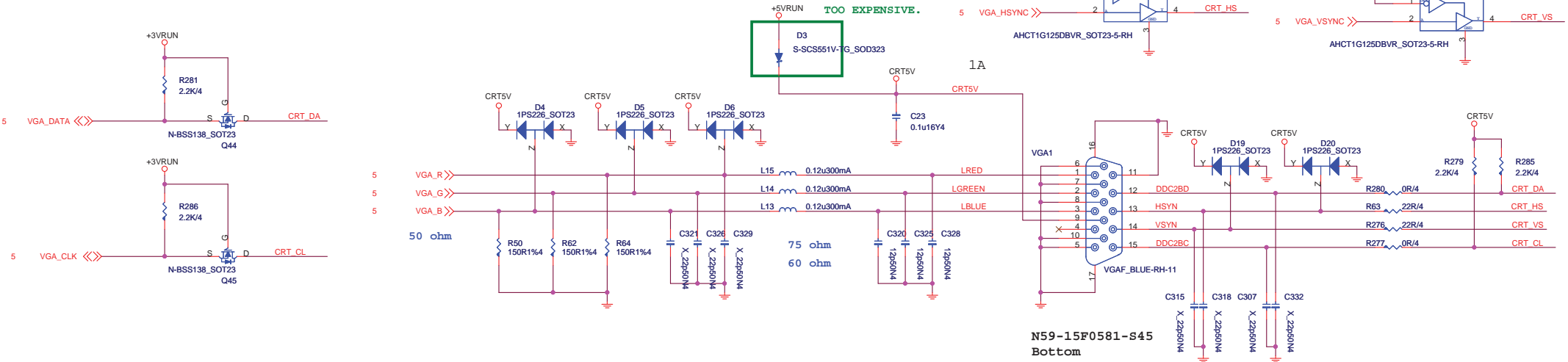

<b>MSI</b>		
<b>MICRO-STAR INT'L CO.,LTD</b>		
<b>MS-N011</b>		
Size Custom	Document Description <b>Audio JACKS</b>	Rev 1.0
Date: Friday, April 11, 2008	Sheet 20 of 39	

# VGA CONN.



N59-15F0581-S45  
Bottom

## LVDS POWER 3.3V

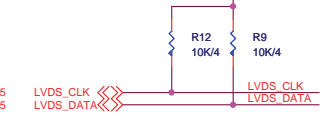
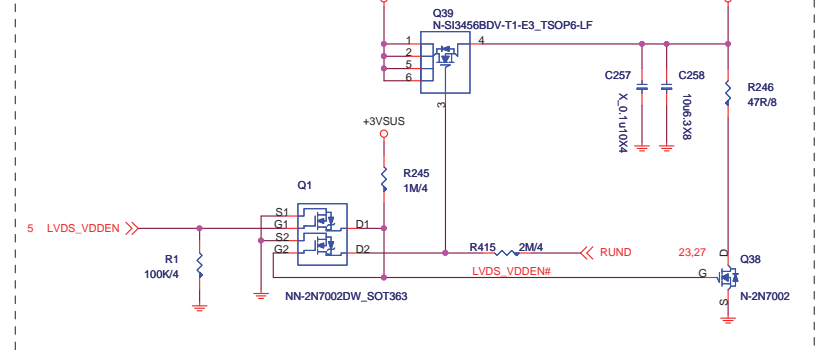

## LVDS CONN.

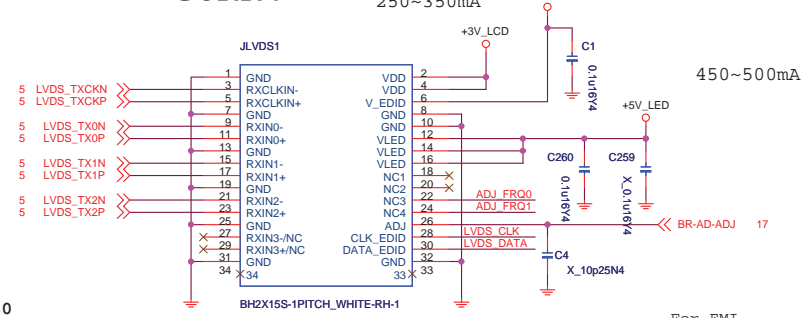

N5Q-30F0030-H21  
Bottom

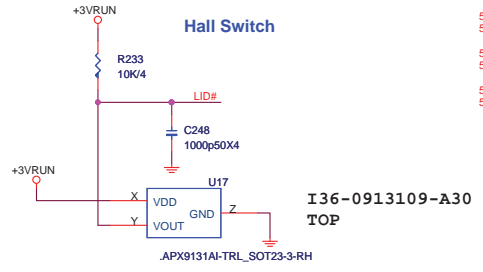

I36-0913109-A30  
TOP

## LED Backlight POWER 5V

LED Drive IC current 5mA when LED OFF by ADJ duty 0.

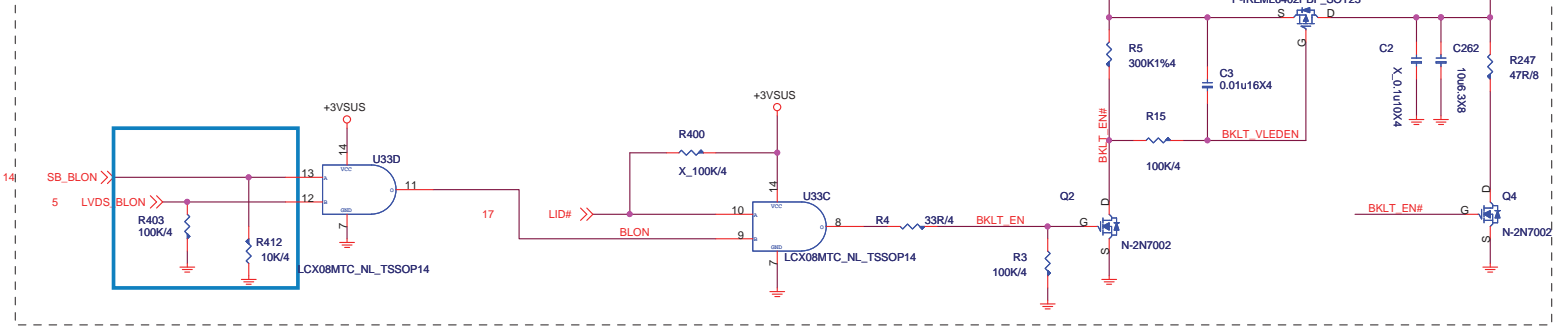

LVDS_TXCKN	R13	200R/4	LVDS_TXCKP
LVDS_TX0N	R11	200R/4	LVDS_TX0P
LVDS_TX1N	R14	200R/4	LVDS_TX1P
LVDS_TX2N	R10	200R/4	LVDS_TX2P

ADJ\_FRQ0 R8 10K/4 EC\_ADJ\_FRQ0 17  
ADJ\_FRQ1 R7 10K/4 EC\_ADJ\_FRQ1 17

EC_ADJ_FRQ0	EC_ADJ_FRQ1	Vendor	Adj Freq
0	0	CPT/HannStar	20KHZ
0	1	INNOLUX	300Hz
1	0	Reserve	Reserve
1	1	Reserve	Reserve

**MSI**

**MICRO-STAR INT'L CO.,LTD**

**MS-N011**

Size Custom Document Description **CRT, LVDS CONN** Rev 1.0

Date: Friday, April 11, 2008 Sheet 21 of 39

# Card Reader controller RTS 5158E

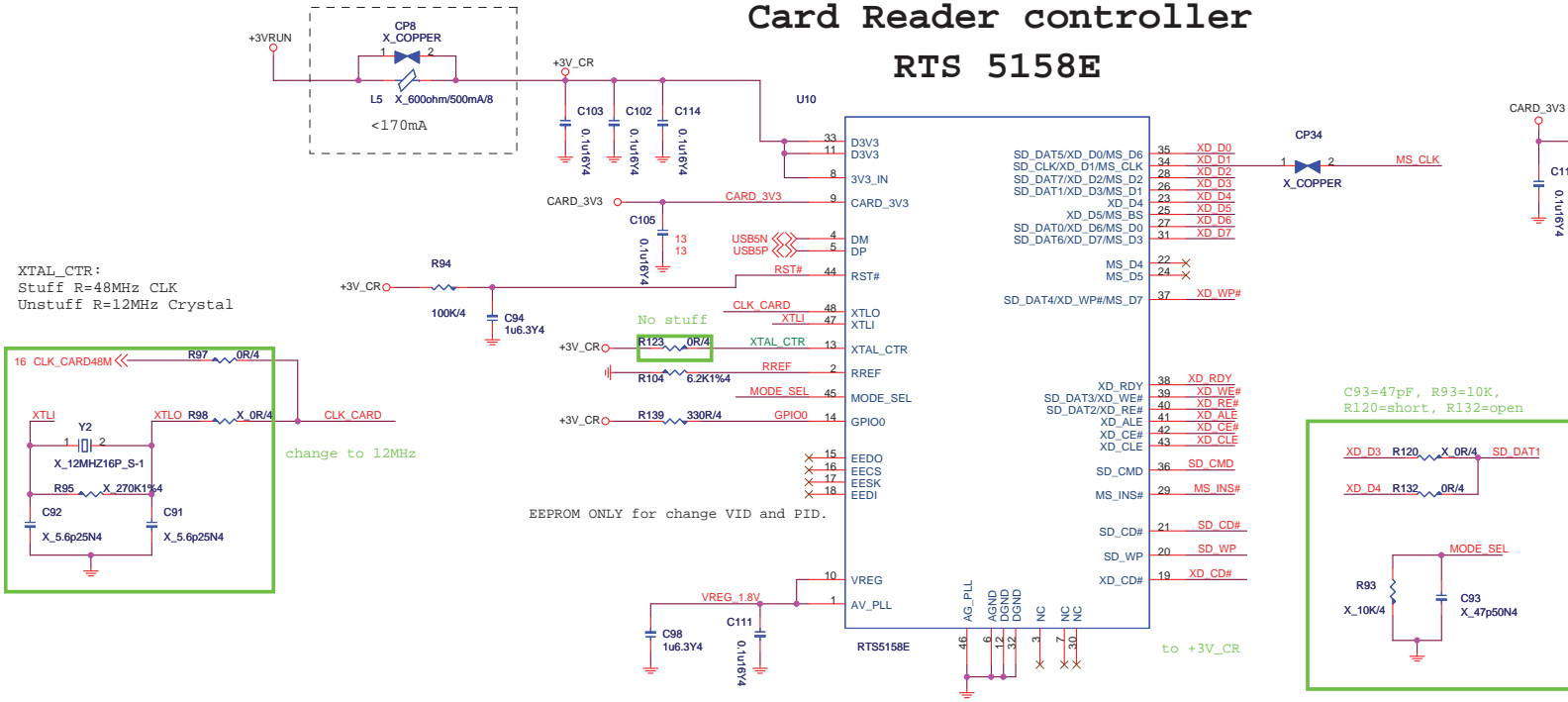

# Flash Card Socket

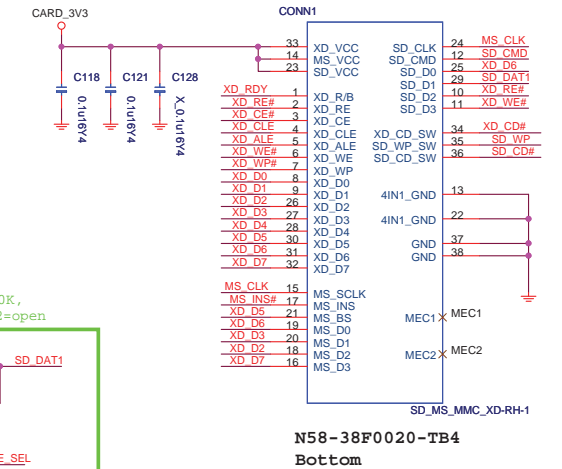

Media I/F (Chip)	SD Card	Memory Stick	xD Card
XD_RDY	X	X	XD_R/B
XD_RE#/SD_DAT2	SD_D2	X	XD_RE
XD_CE#	X	X	XD_CE
XD_CLE	X	X	XD_CLE
XD_ALE	X	X	XD_ALE
XD_WE#/SD_DAT3	SD_D3	X	XD_WE
XD_WP#/SD_DAT4/MS_D7	X	X	XD_WP
XD_D0/SD_DAT0/MS_D6	X	X	XD_D0
XD_D1/SD_CLK/MS_CLK	SD_CLK	MS_CLK	XD_D1
XD_D2/SD_DAT7/MS_D2	X	MS_D2	XD_D2
XD_D3/SD_DAT1/MS_D1	SD_D1	MS_D1	XD_D3
XD_D4	X	X	XD_D4
XD_D5/MS_BS	X	MS_BS	XD_D5
XD_D6/SD_DAT0/MS_D0	SD_D0	MS_D0	XD_D6
XD_D7/SD_DAT6/MS_D3	X	MS_D3	XD_D7
XD_CD#	X	X	XD_CD_SW
SD_CMD	SD_CMD	X	X
SD_CD#	SD_CD_SW	X	X
SD_WP	SD_WP_SW	X	X
MS_INS#	X	MS_INS	X
MS_D4	X	X	X
MS_D5	X	X	X

# SATA HDD

SATA, 2.5 inch, 80GB, 5400RPM  
 WD S71-2408505-W36  
 Fujitsu S71-2408511-F06  
 Toshiba S71-2408517-T14

# BLUETOOTH

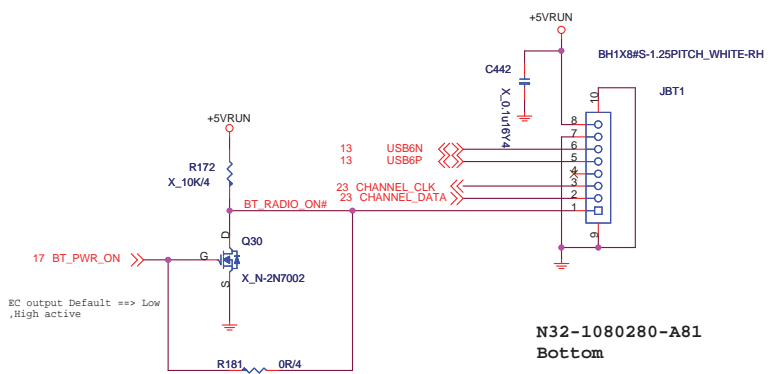

# SATA HDD CONN

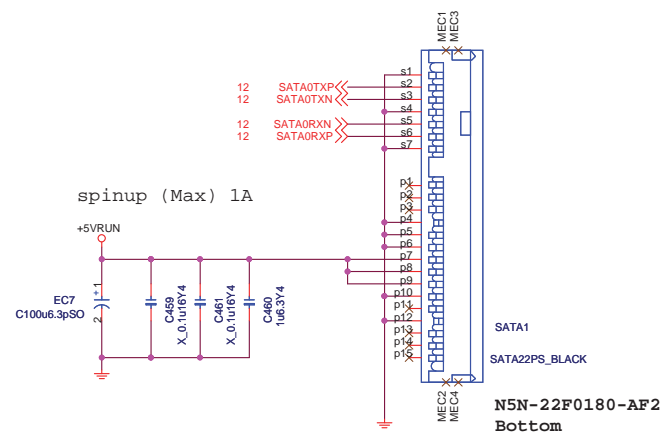

**MICRO-STAR INT'L CO.,LTD**

**MS-N011**

Size Custom	Document Description CardReader RTS5158E/ BT/ SATA HDD	Rev 1.0
Date: Friday, April 11, 2008	Sheet 22 of 39	

# Mini PCIE Slot

## Wireless LAN

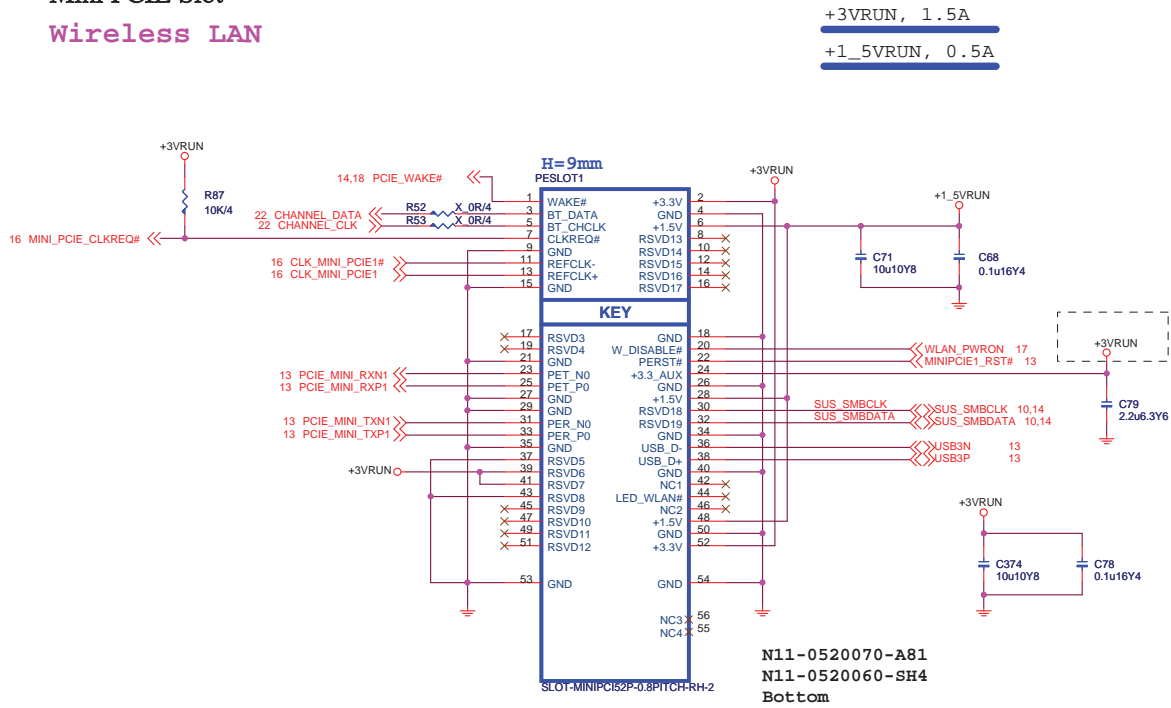

# USB CONN

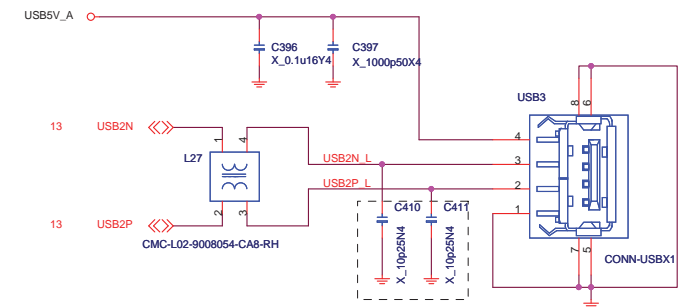
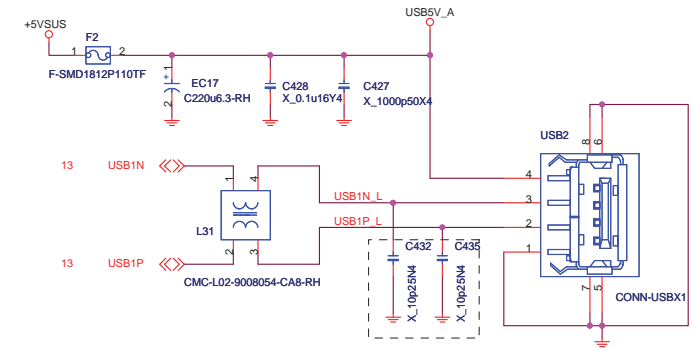
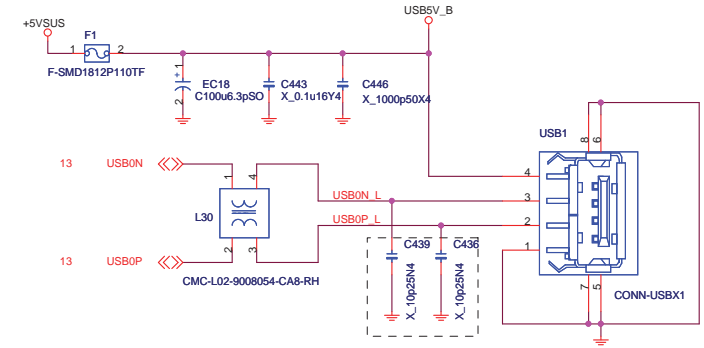

DOG-25B0600-R02  
DIS EMI/ESD PROTECTOR, RAYCHEM/PESD0402-060, 6V, 0.25pF,  
, SMD-1.0x0.5x0.38mm, ESD PROTECTOR, RoHS (EU EXEMPTION)

# CAMERA

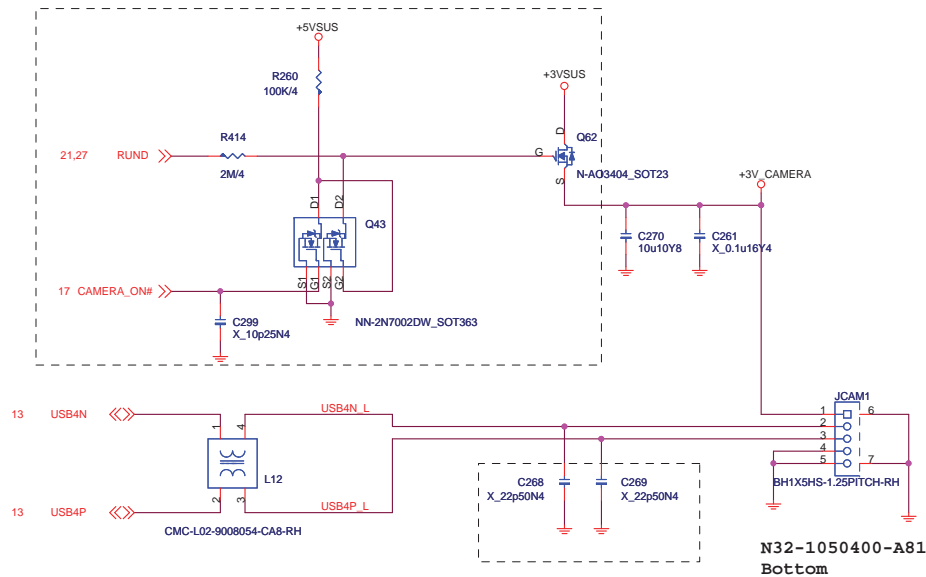

<b>MICRO-STAR INT'L CO.,LTD</b>			
<b>MS-N011</b>			
Size	Document Description	Rev	
Custom	Mini PCIE, CAMERA, USB CONN	1.0	
Date:	Friday, April 11, 2008	Sheet	23 of 39





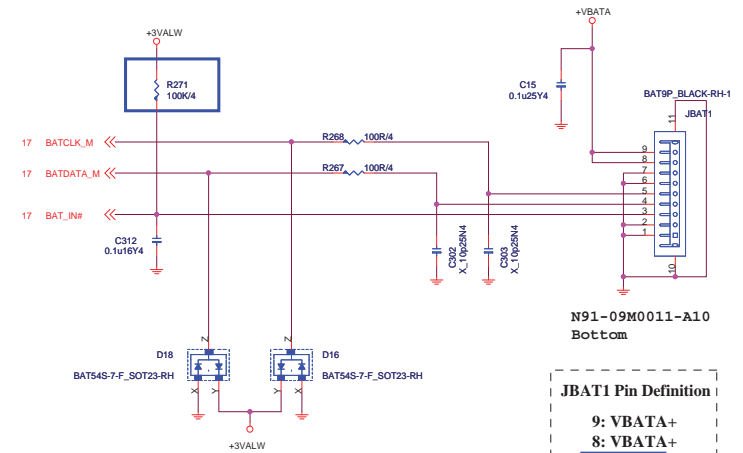
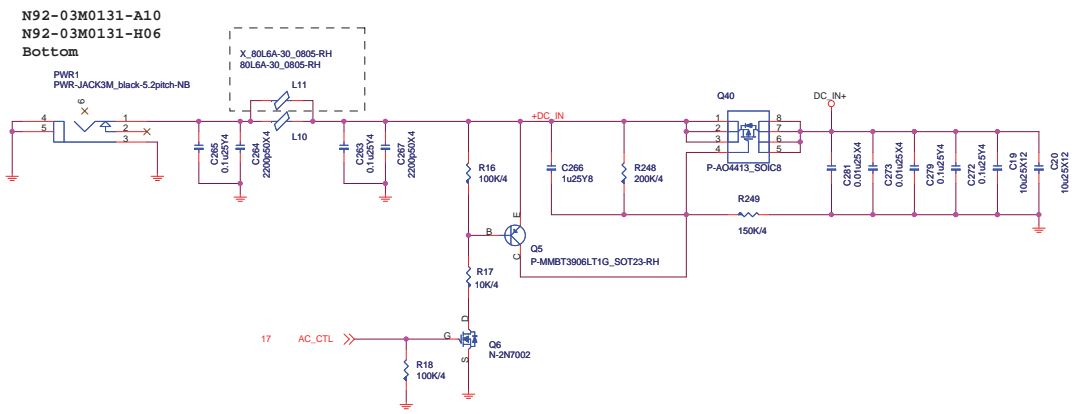

**JBAT1 Pin Definition**

- 9: VBATA+
- 8: VBATA+
- 7: NC
- 6: NC
- 5: SMBCLK
- 4: SMBDATA
- 3: BAT\_IN#
- 2: GND
- 1: GND

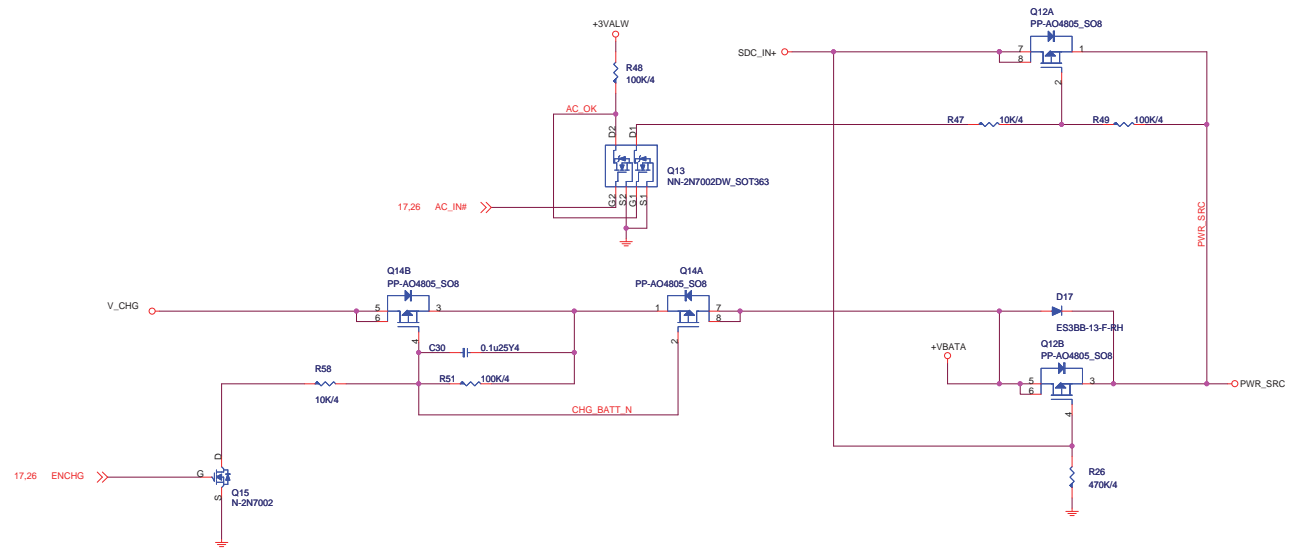

Adapter= 40 W  
 Adapter input voltage set 20 Voltage 2 Amps

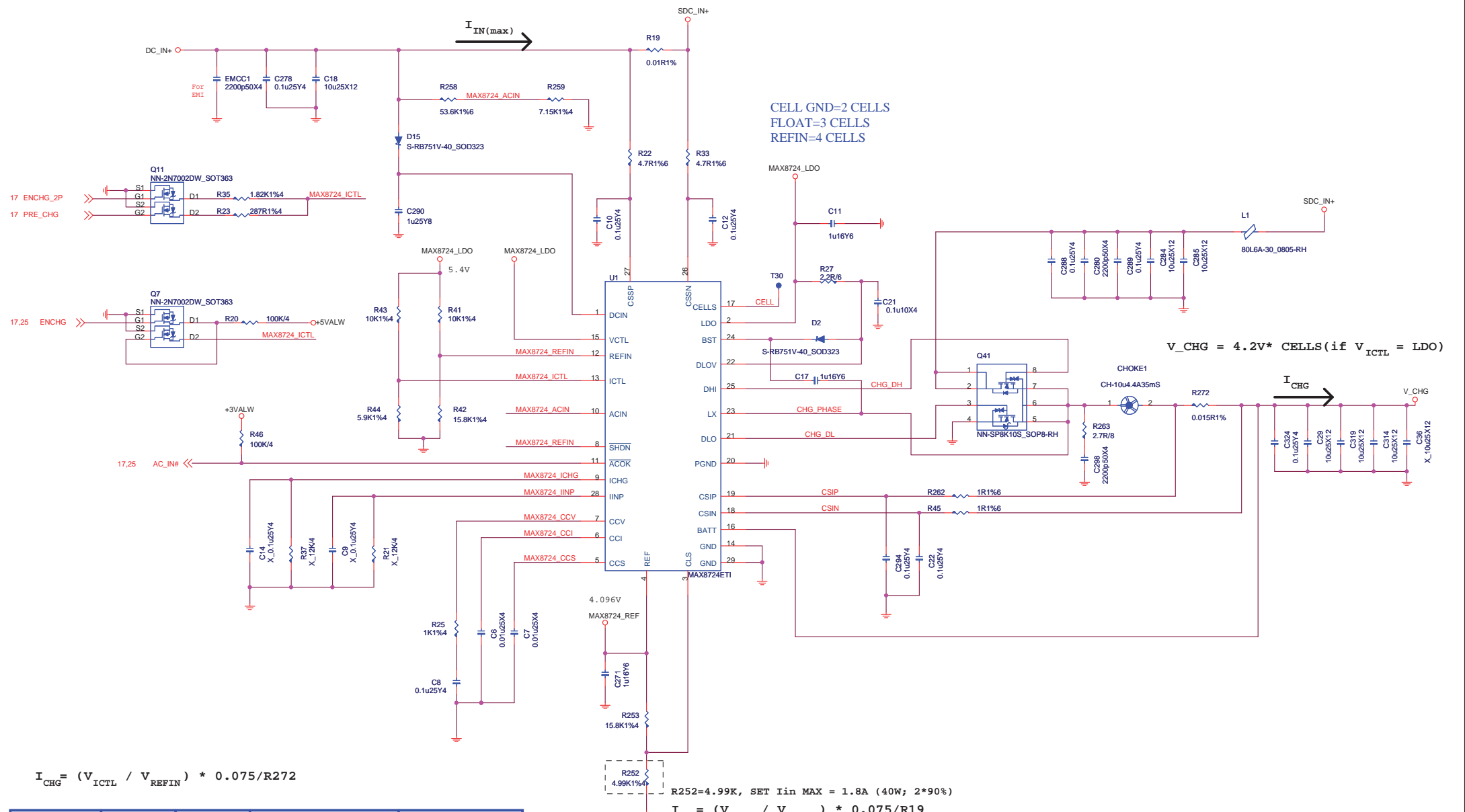

CELL GND=2 CELLS  
 FLOAT=3 CELLS  
 REFIN=4 CELLS

$V_{CHG} = 4.2V * CELLS$  (if  $V_{ICTL} = LDO$ )

$I_{CHG} = (V_{ICTL} / V_{REFIN}) * 0.075 / R272$

$R252 = 4.99K, SET I_{in} MAX = 1.8A (40W; 2*90\%)$

$I_{IN} = (V_{CLS} / V_{REF}) * 0.075 / R19$

ENCHG-2P	PRE_CHG	ENCHG	charge status	charge current
0	1	1	Pre-charge	220 mA
1	0	1	3S-Fast charge	1.0 A
0	0	1	3S2P-Fast charge	3A
X	X	0	STOP CHARGE	0

3S battery max charge current 1540mA, 0.7C=>1000mA

<b>MICRO-STAR INT'L CO.,LTD</b>		
<b>MS-N011</b>		
Size Custom	Document Description <b>Battery Charger</b>	Rev 1.0
Date: Friday, April 11, 2008		Sheet 26 of 39

0.747A  
 ICH7M : 132mA ;  
 PCIE LAN: 365mA ;  
 MINI PCIE +3VRUN: 250mA ;

2.188A  
 945GMS +3VRUN : 40mA ;  
 ICH7M +3VRUN : 336mA ;  
 ICH7M +2\_5VRUN : 142mA ;  
 MINI PCIE +3VRUN: 1250mA ;  
 CLOCK Gen: 200mA ;  
 CardReader: 170mA ;  
 Audio 888S: 50mA ;  
 CAMERA: ??mA ;

Current limit at 4A for +3.3V

**+3VSUS**

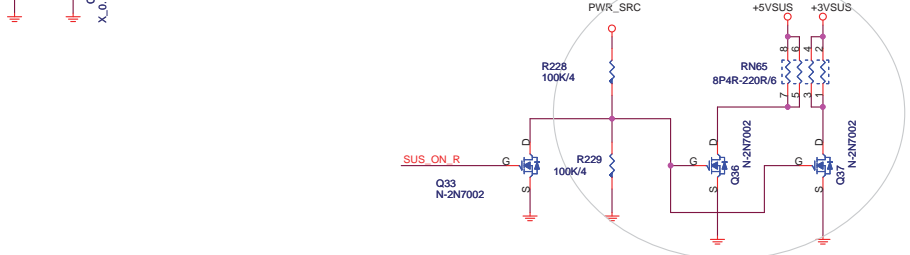
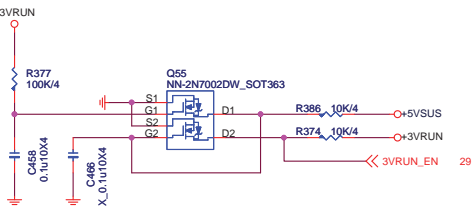
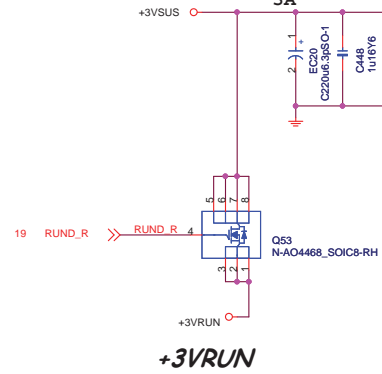

\*\*\*NEXT VERSION CHANGE TO TI/TPS51125 FOR COST DOWN\*\*\*

**+5VALW**

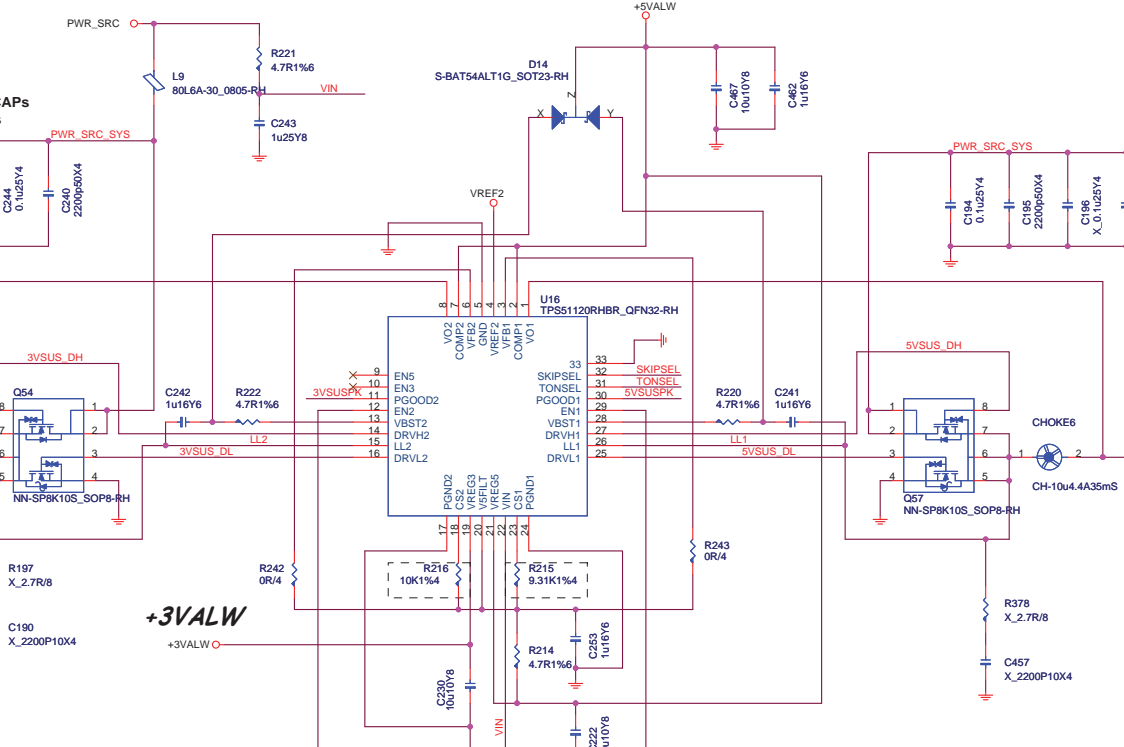

Current limit at 4A for +5VSUS

**+5VSUS** 1.71A  
 ICH7M V5REF\_SUS: 10mA ;  
 USB 3 ports: 1.5A ;  
 Audio ADD5V: 200mA ;

**+5VRUN**

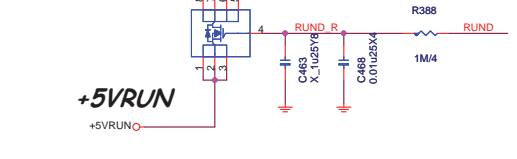

2.17A  
 ICH7M V5REF: 6mA ;  
 SATA HDD: 1A ;  
 RGB CRT \_5V: 1000mA ;  
 LED 8 pcs: 160mA ;  
 Touch pad: 2.5mA ;  
 Blue Tooth: ???mA ;

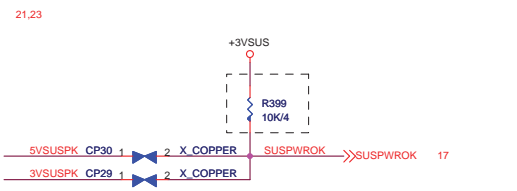

	<b>MICRO-STAR INT'L CO.,LTD</b>		
	<b>MS-N011</b>		
	Size Custom	Document Description System Power	Rev 1.0
	Date: Friday, April 11, 2008	Sheet 27 of 39	

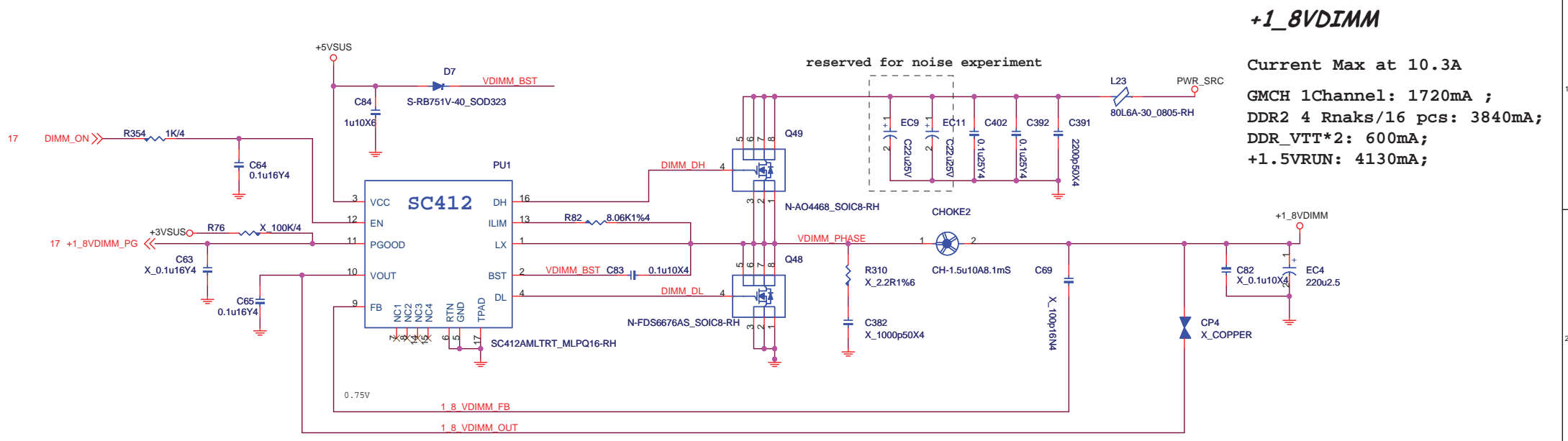

**+1\_8VDIMM**

Current Max at 10.3A

GMCH 1Channel: 1720mA ;  
 DDR2 4 Rnaks/16 pcs: 3840mA;  
 DDR\_VTT\*2: 600mA;  
 +1.5VRUN: 4130mA;

**VDIMM OC**

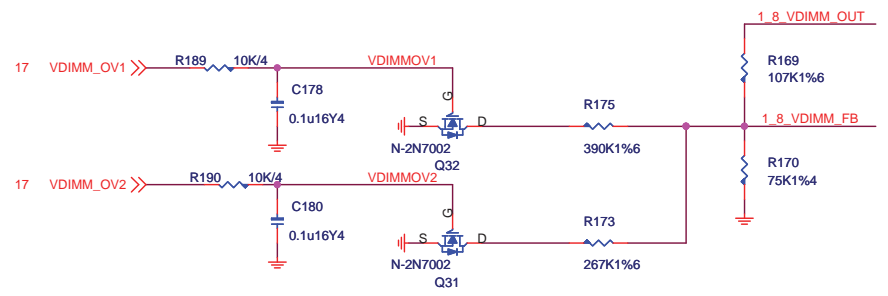

**VDIMM OverVoltage TABLE**

OV1	OV2	VDIMM OverVoltage
0	0	1.85V(default)
1	0	2V
0	1	2.15V

Note: 1=> HIGH 0=> LOW

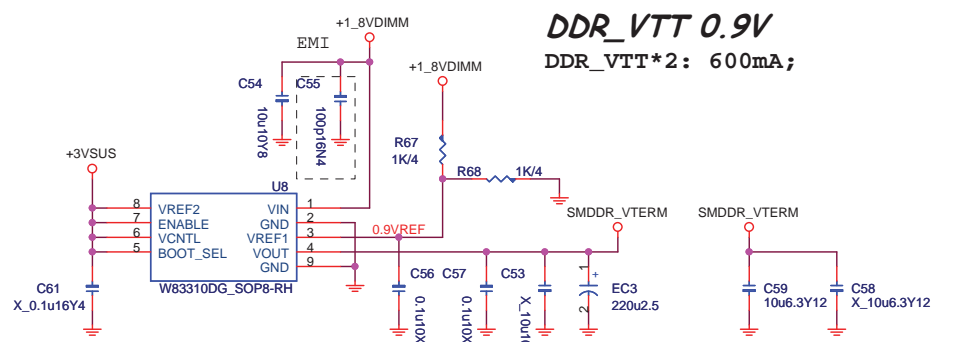

**DDR\_VTT 0.9V**

DDR\_VTT\*2: 600mA;

<b>MICRO-STAR INT'L CO.,LTD</b>		
<b>MS-N011</b>		
Size B	Document Description <b>DDR &amp; VTT_DDR Power</b>	Rev 1.0
Date: Friday, April 11, 2008	Sheet 28	of 39

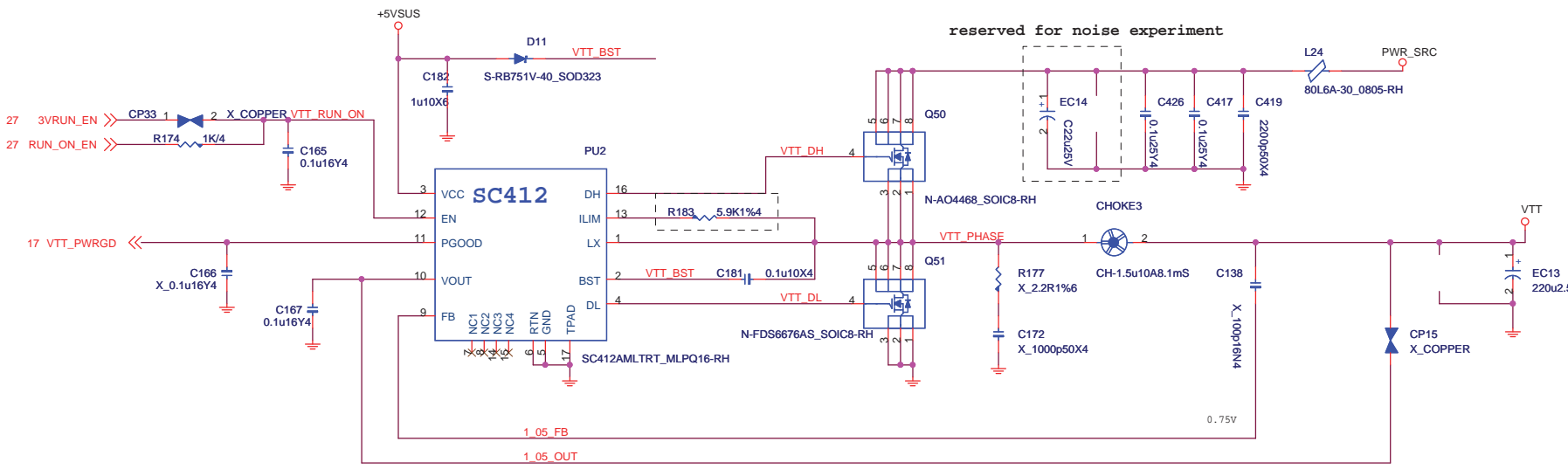

**VTT /+1.05Vcore**  
6.674A

Current Limit at 10A  
Current MAX at 8A

CPU Vccp: 2000mA  
GMCH core:2940mA  
GMCH Vccp:780mA  
ICH7M core:940mA  
ICH7M Vcc\_IO:14mA

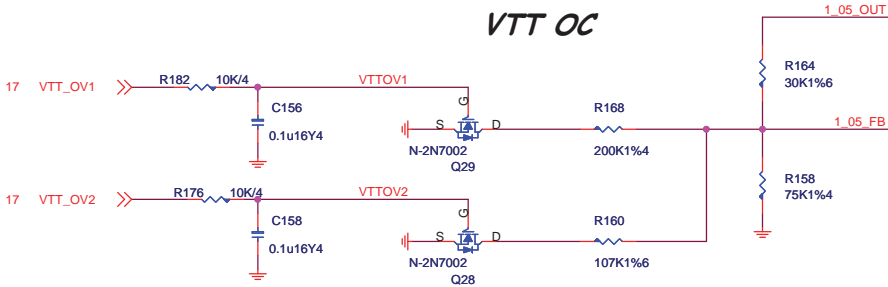

VTT OverVoltage TABLE

OV1	OV2	VTT OverVoltage
0	0	1.05V(default)
1	0	1.15V
0	1	NA

Note: 1=> HIGH 0=> LOW

**+2\_5VRUN** 142mA

up7707: 600mA Low Dropout Linear Regulator

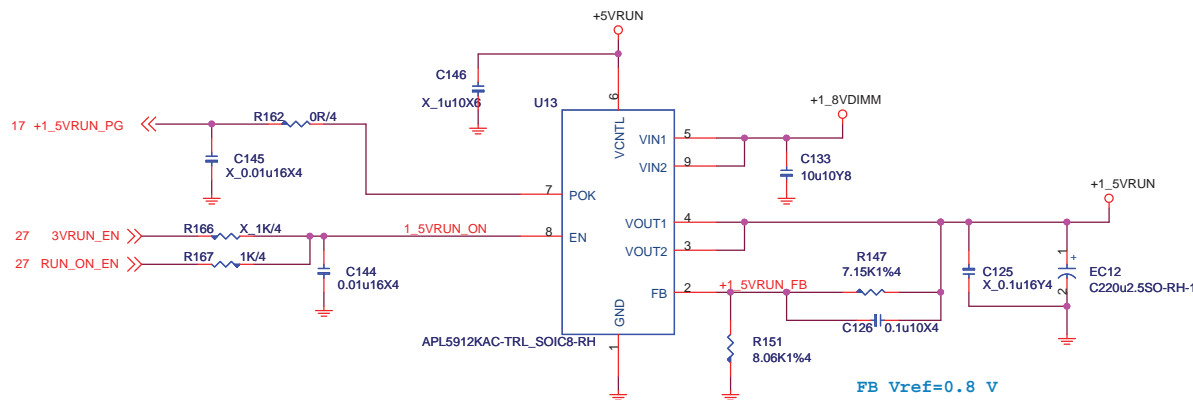
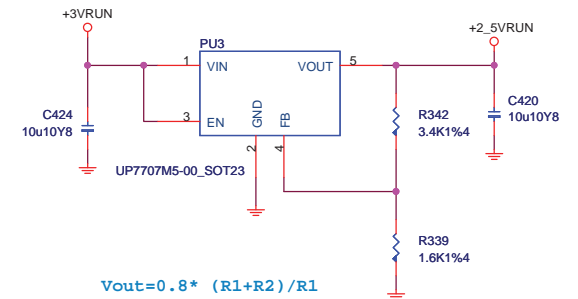

**+1.5Vcore**

4.13A

CPU Vccp: 130mA  
GMCH core:1980mA  
ICH7M core:1520mA  
MINI PCIE :500mA

<b>MSI</b>		
<b>MICRO-STAR INT'L CO.,LTD</b>		
<b>MS-N011</b>		
Size Custom	Document Description <b>1.05V, 1.5V, 2.5V- POWER</b>	Rev 1.0
Date: Friday, April 11, 2008	Sheet 29	of 39

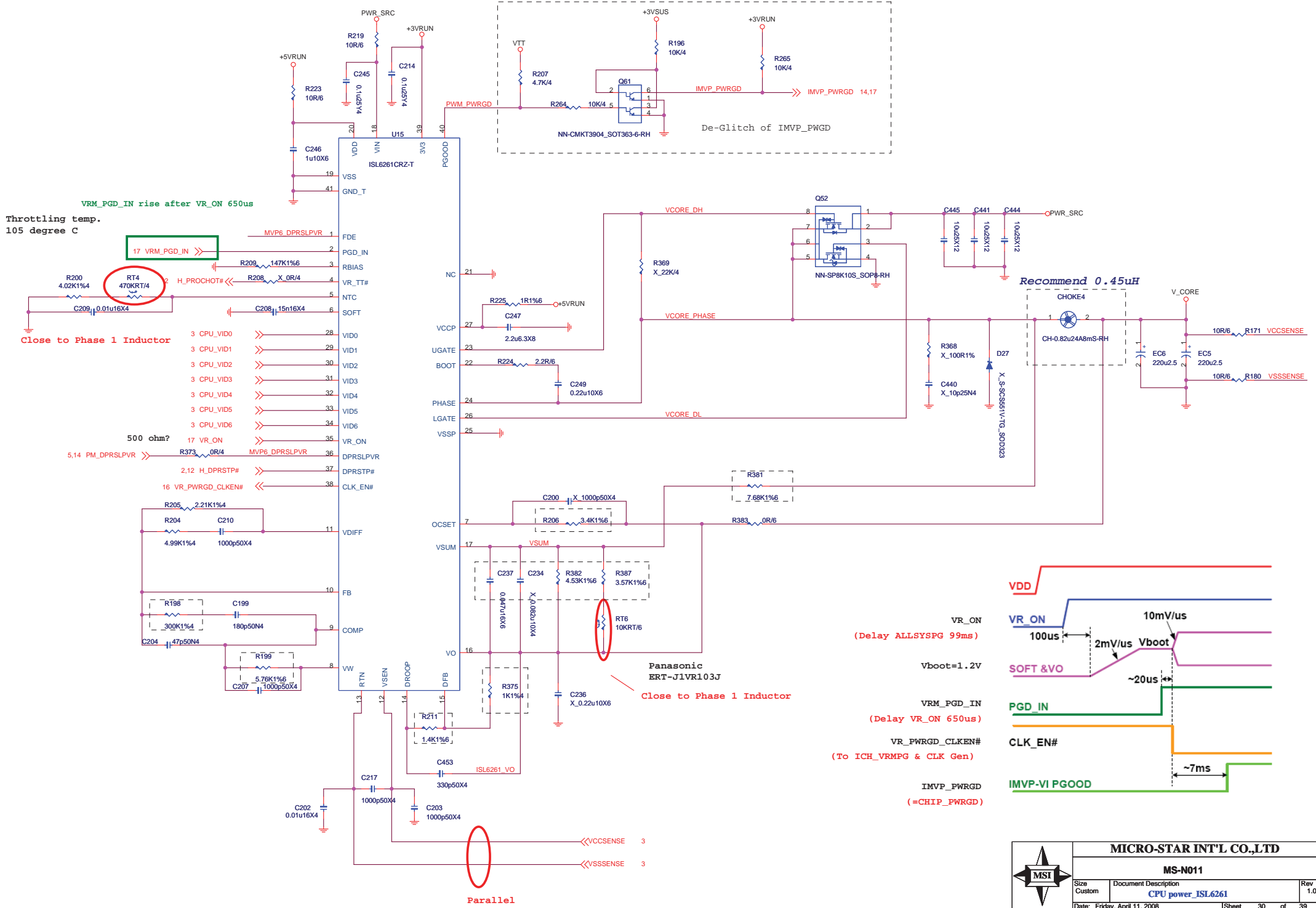

VRM\_PGD\_IN rise after VR\_ON 650us  
Throttling temp.  
105 degree C

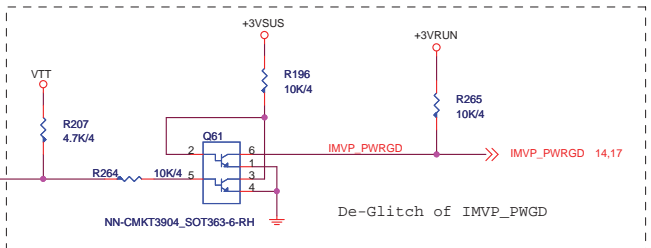
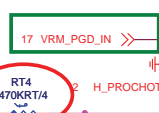

Recommend 0.45uH

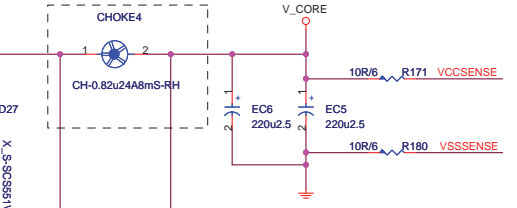

VR\_ON  
(Delay ALLSYSPPG 99ms)

Vboot=1.2V

VRM\_PGD\_IN  
(Delay VR\_ON 650us)

VR\_PWRGD\_CLKEN#  
(To ICH\_VRMPPG & CLK Gen)

IMVP\_PWRGD  
(=CHIP\_PWRGD)

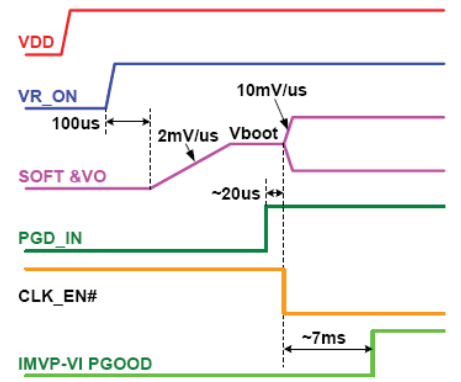

<b>MICRO-STAR INT'L CO.,LTD</b>		
<b>MS-N011</b>		
Size Custom	Document Description <b>CPU power_ISL6261</b>	Rev 1.0
Date: Friday, April 11, 2008	Sheet 30	of 39

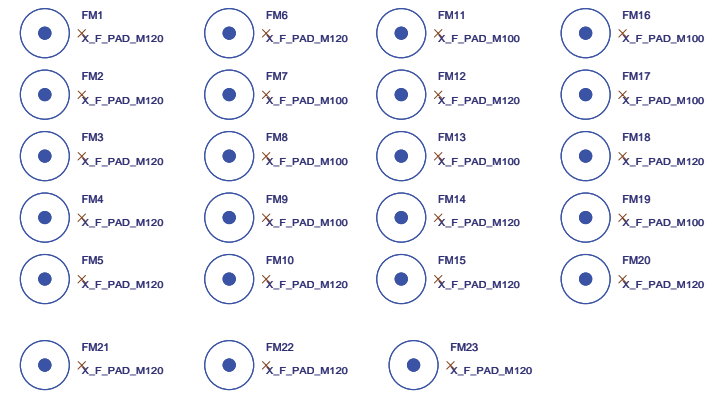
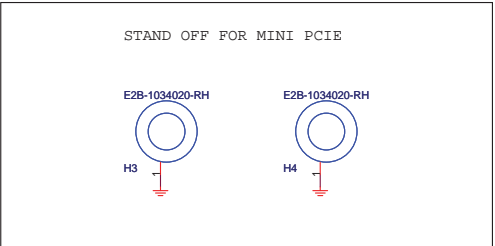
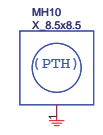
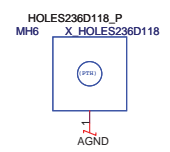
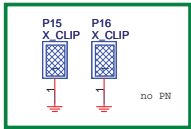
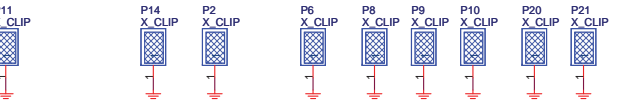
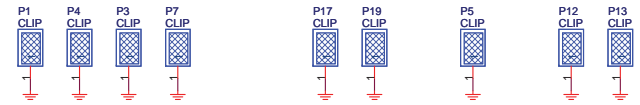
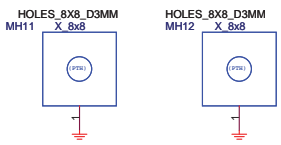
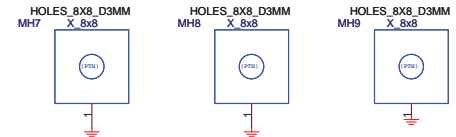
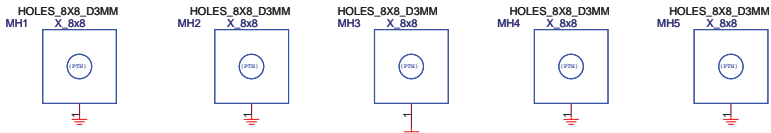

**Simulation**

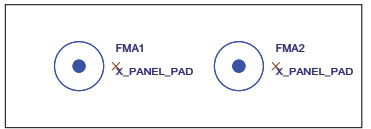
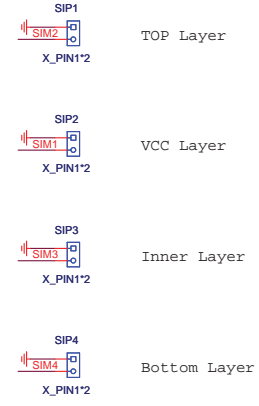

OPT	Configure	BOM	Function
A	cfg-FS	607-N0111-01S	MS-N0111 OPT:A Diamondville CPU, 945GMS+ICH7M, 1G SAMSUNG DDR2), ALC888S,ENE3310,Relteak 5158E+RTL8102E
B	cfg-FH	607-N0111-02S	MS-N0111 OPT:B Diamondville CPU, 945GMS+ICH7M, 1G HYNIX DDR2), ALC888S,ENE3310,Relteak 5158E+RTL8102E
C	cfg-FM	607-N0111-03S	MS-N0111 OPT:C Diamondville CPU, 945GMS+ICH7M, 512M MIRA DDR2), ALC888S,ENE3310,Relteak 5158E+RTL8102E

**MICRO-STAR INT'L CO.,LTD**

**MS-N011**

Size Custom	Document Description <b>Screw</b>	Rev 1.0
Date: Tuesday, April 15, 2008		Sheet 31 of 39

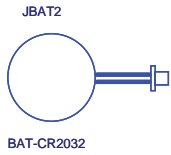

P30-N011110-H73/D05/Y34

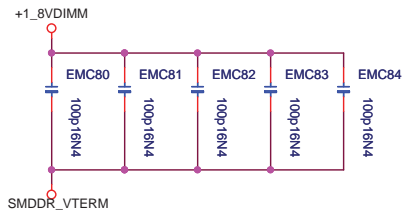
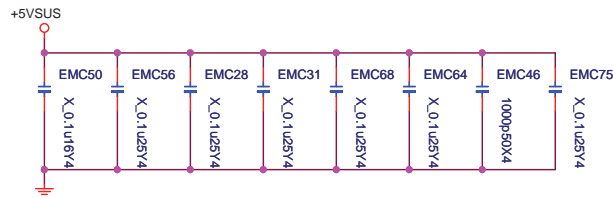
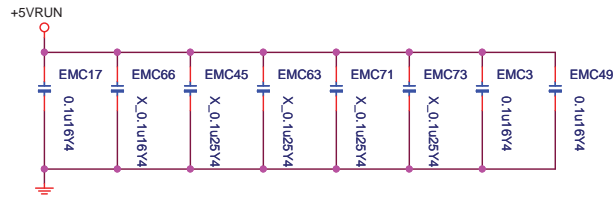
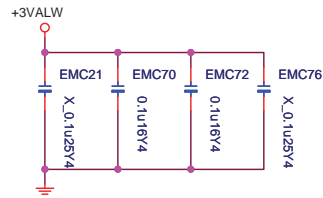
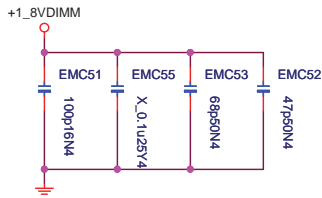

SMDDR\_VTERM

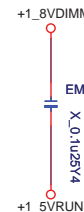
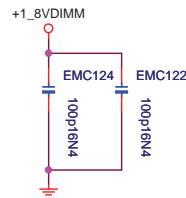
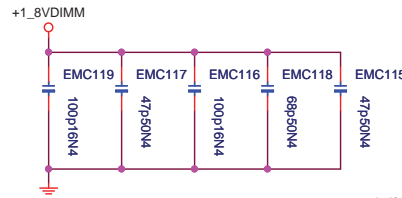
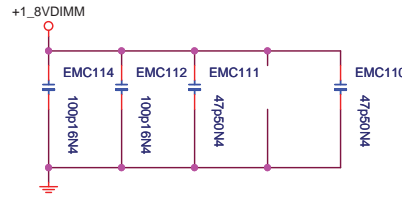
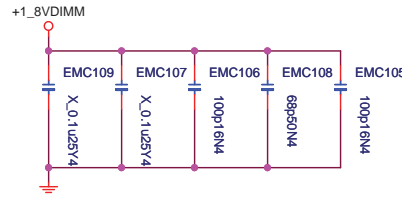
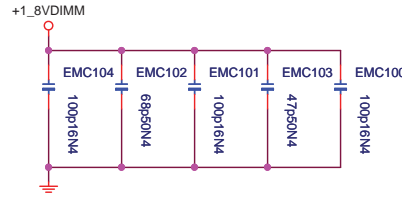
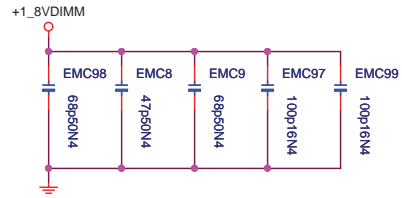

+1\_5VRUN

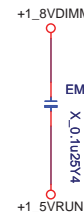
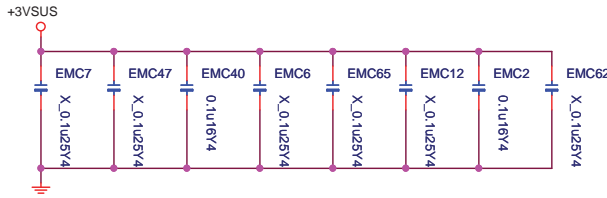
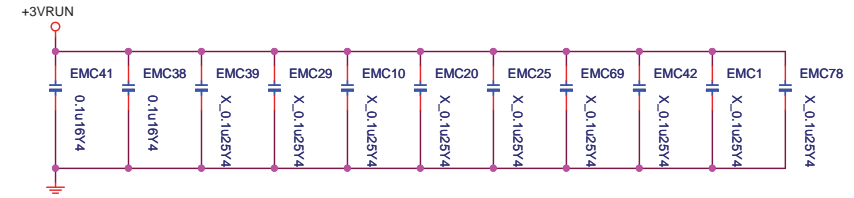
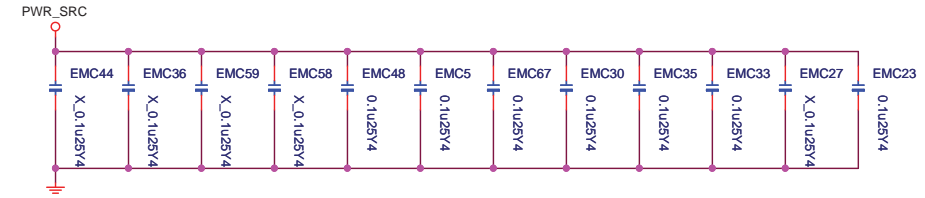
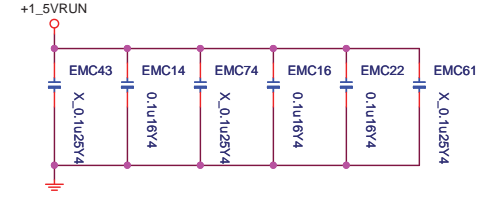
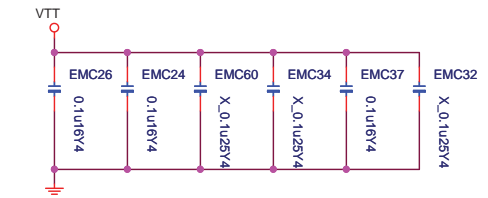
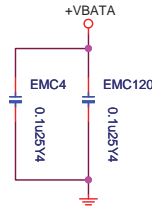
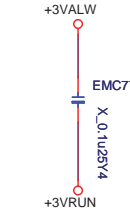

VTT

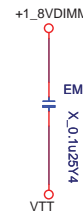

+1\_5VRUN



MICRO-STAR INT'L CO.,LTD

MS-N011

Size B	Document Description	Rev 1.0
Manual Parts		
Date: Friday, April 11, 2008	Sheet 32	of 39



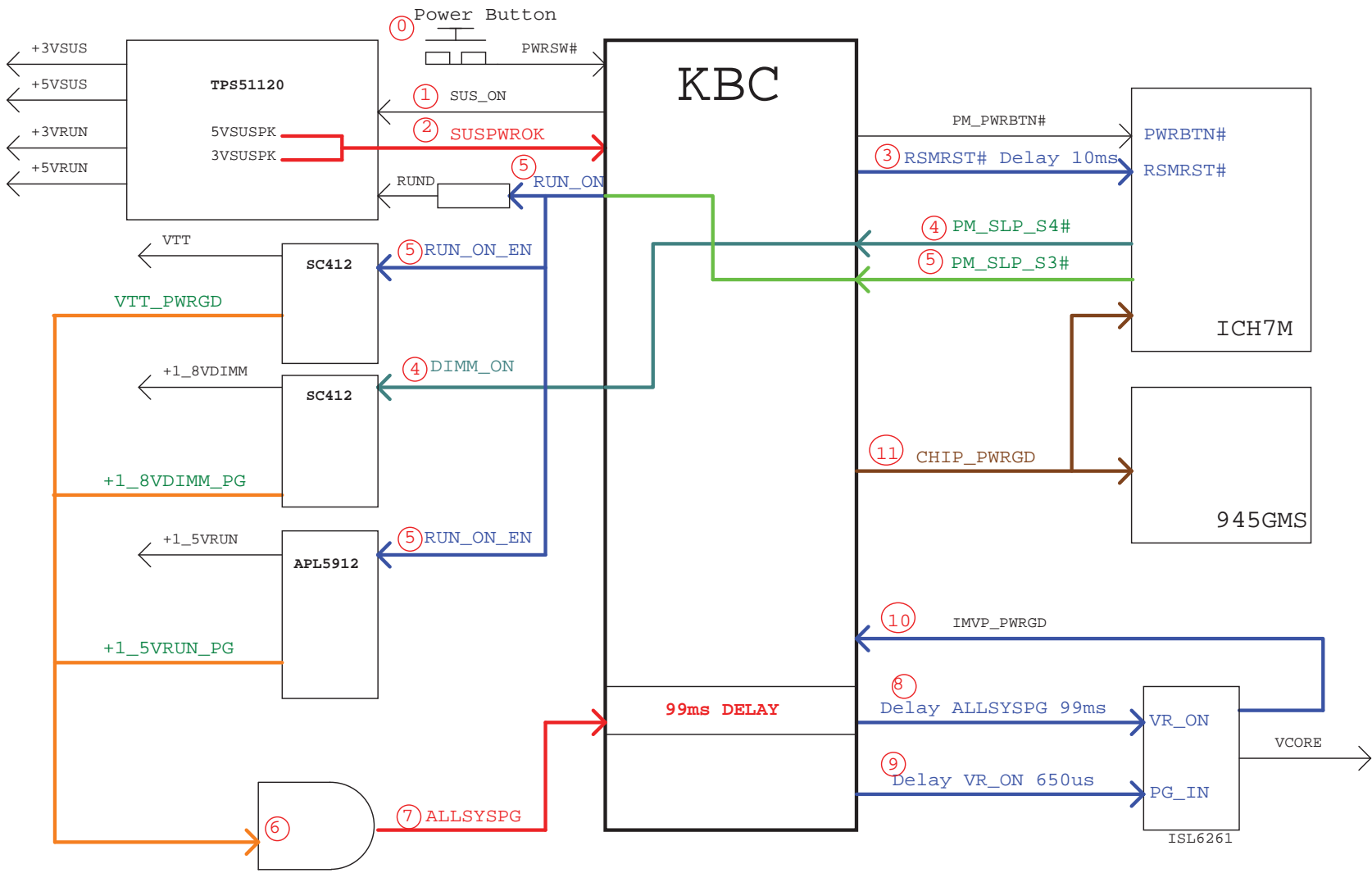

<b>MICRO-STAR INT'L CO.,LTD</b>		
<b>MS-N011</b>		
Size B	Document Description <b>KBC_CTR_PWR_BD</b>	Rev 1.0
Date: Friday, March 28, 2008		Sheet 33 of 39

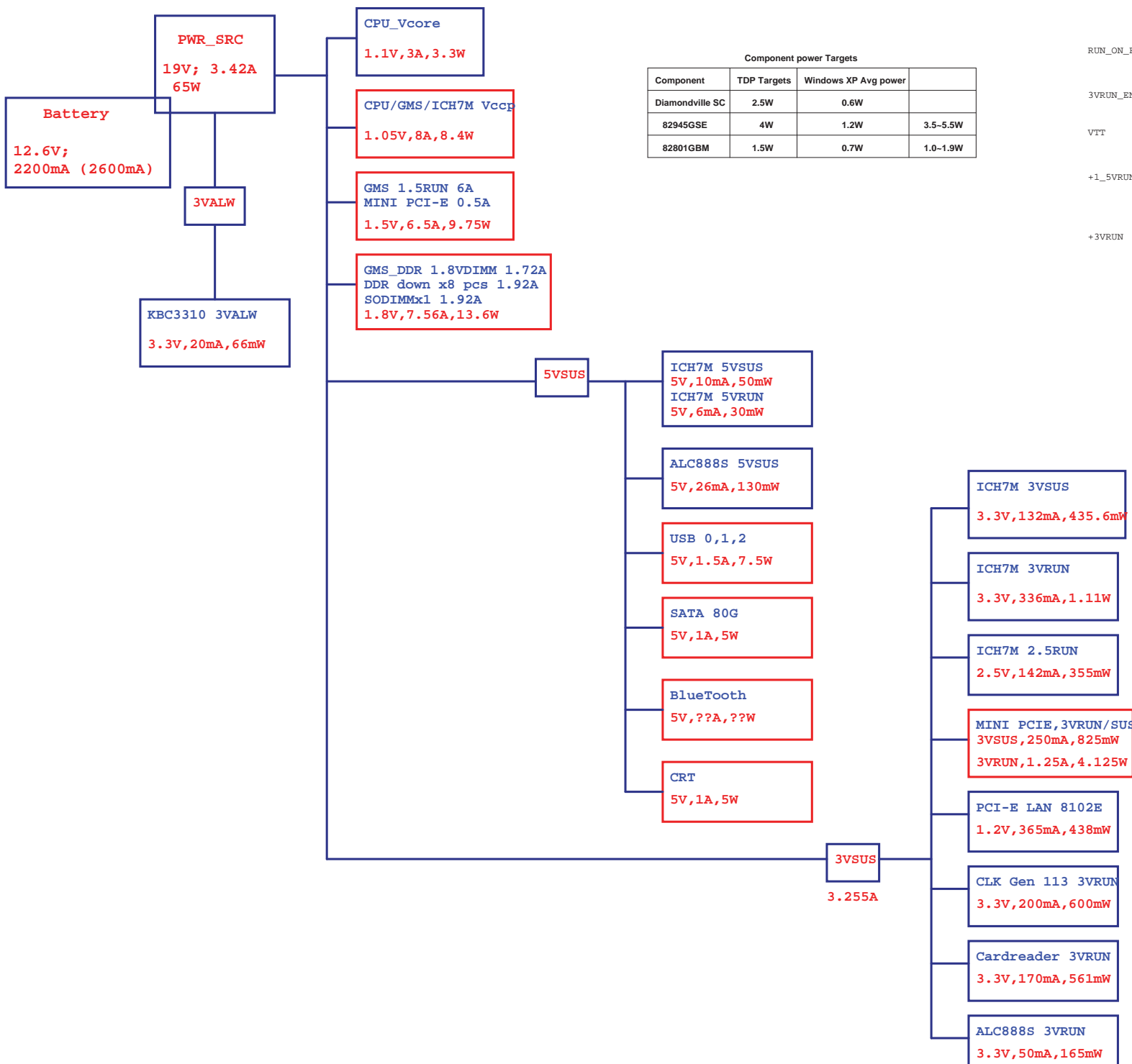

Component power Targets

Component	TDP Targets	Windows XP Avg power	
Diamondville SC	2.5W	0.6W	
82945GSE	4W	1.2W	3.5-5.5W
82801GBM	1.5W	0.7W	1.0-1.9W

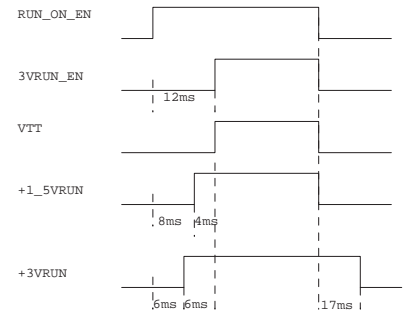

RED: POWER  
BLACK: KBC

Battery Mode G3 - S0 - G3

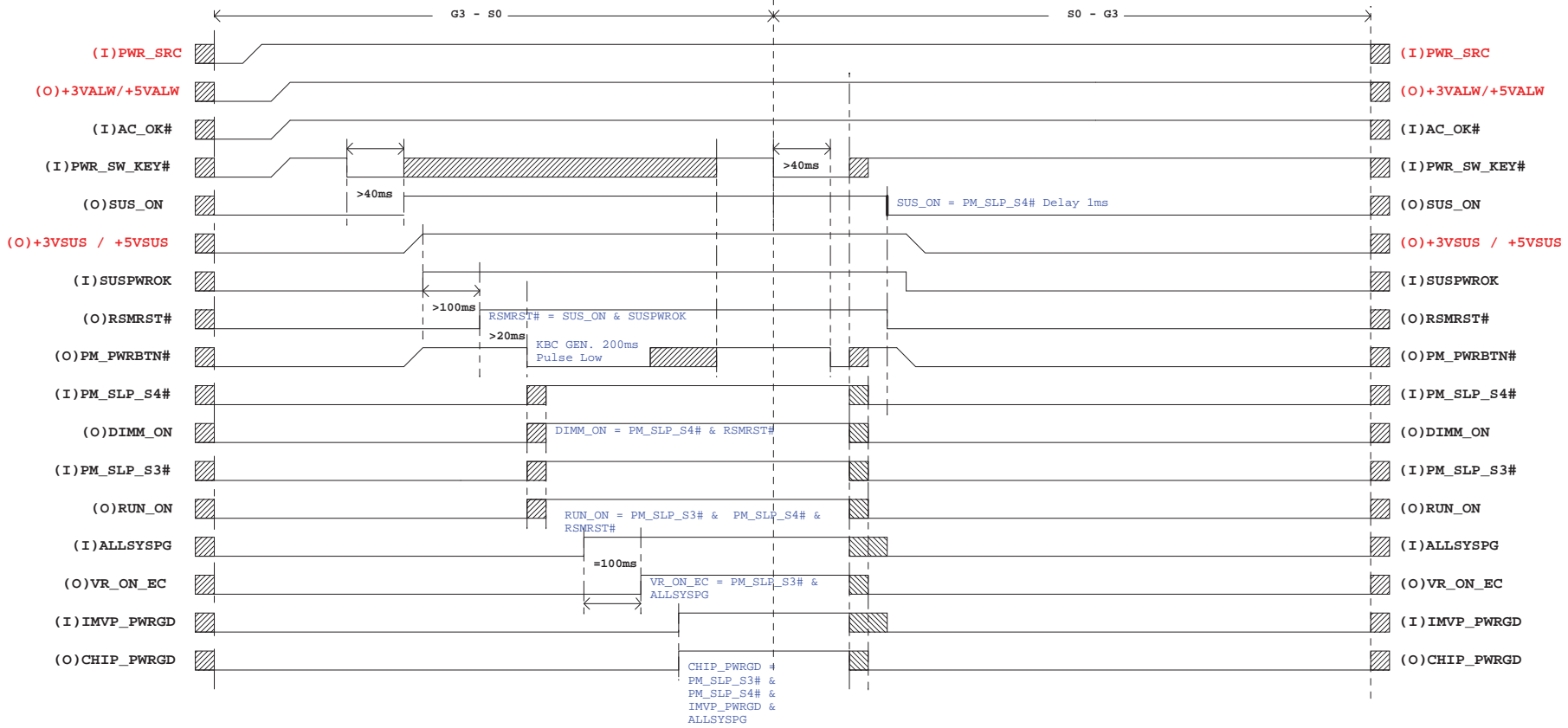

<b>MICRO-STAR INT'L CO.,LTD</b>			
<b>MS-N011</b>			
Size Custom	Document Description <b>timing1</b>	Rev 1.0	
Date: Friday, March 28, 2008		Sheet	35 of 39

RED: POWER  
BLACK: KBC

### Battery Mode S0 - S3 - S0

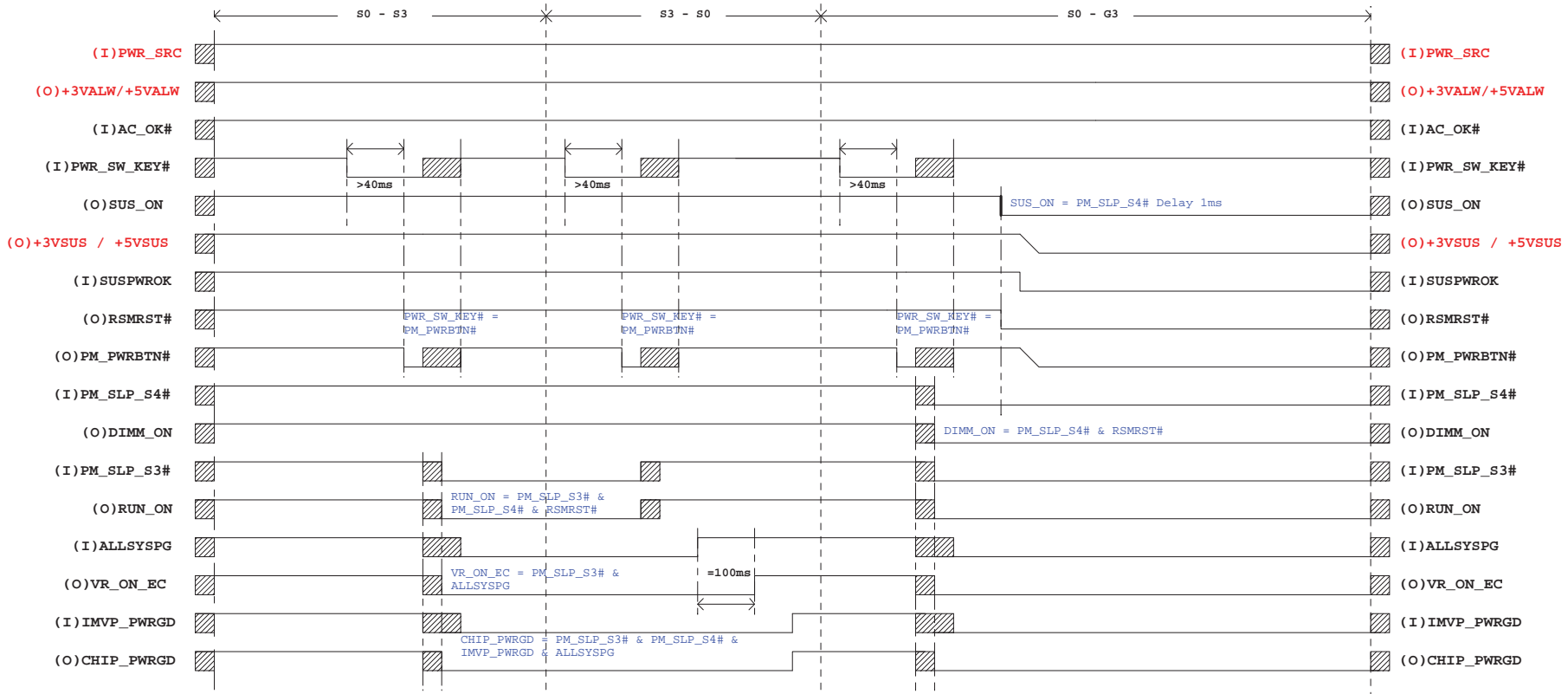

	<b>MICRO-STAR INT'L CO.,LTD</b>		
	<b>MS-N011</b>		
	Size Custom	Document Description timing2	Rev 1.0
Date: Friday, March 28, 2008		Sheet 36 of 39	

RED: POWER  
BLACK: KBC

AC Mode G3 - S5 - S0 - S5 - G3

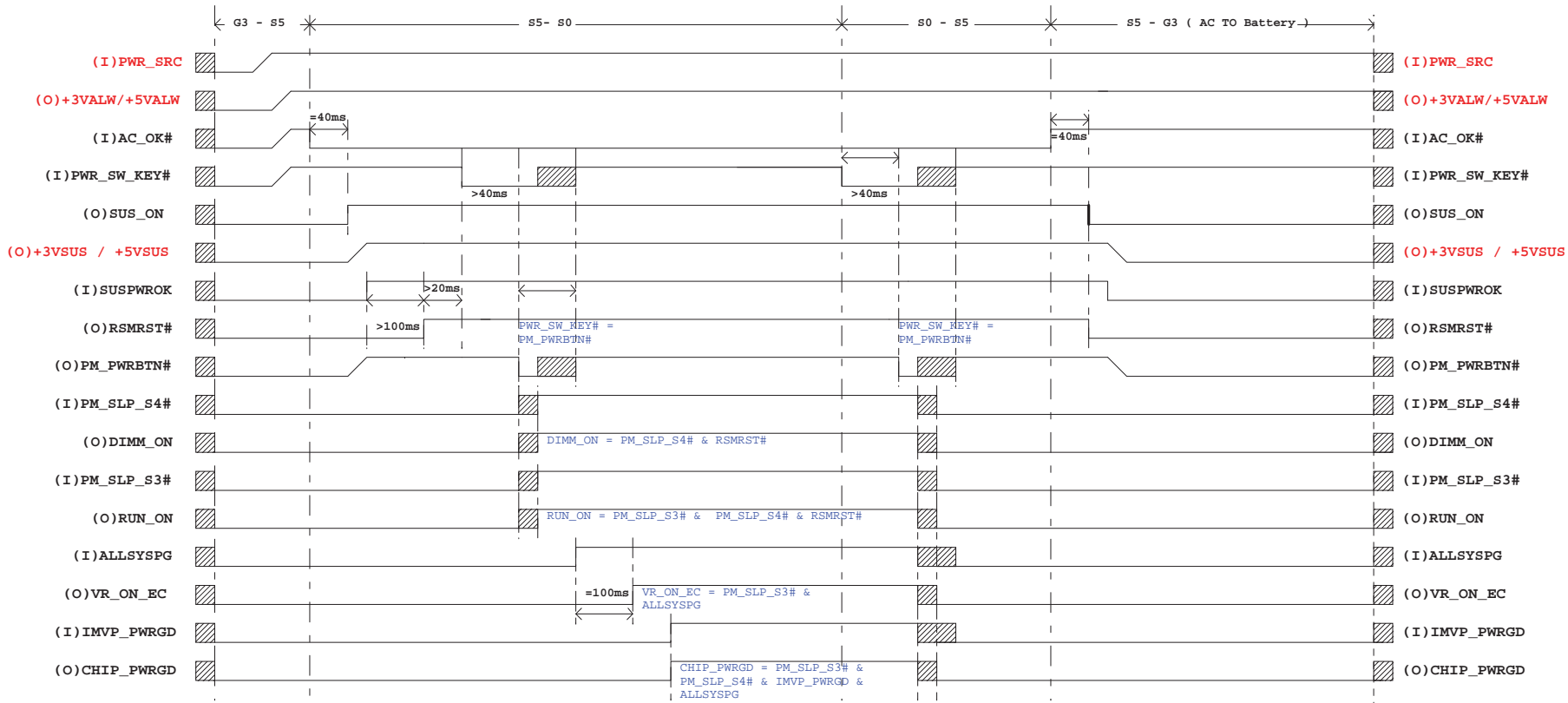

<b>MICRO-STAR INT'L CO.,LTD</b>			
<b>MS-N011</b>			
Size Custom	Document Description <b>timing3</b>		Rev 1.0
Date: Friday, March 28, 2008		Sheet	37 of 39

RED: POWER  
BLACK: KBC

AC Mode S0 - S3 - S0

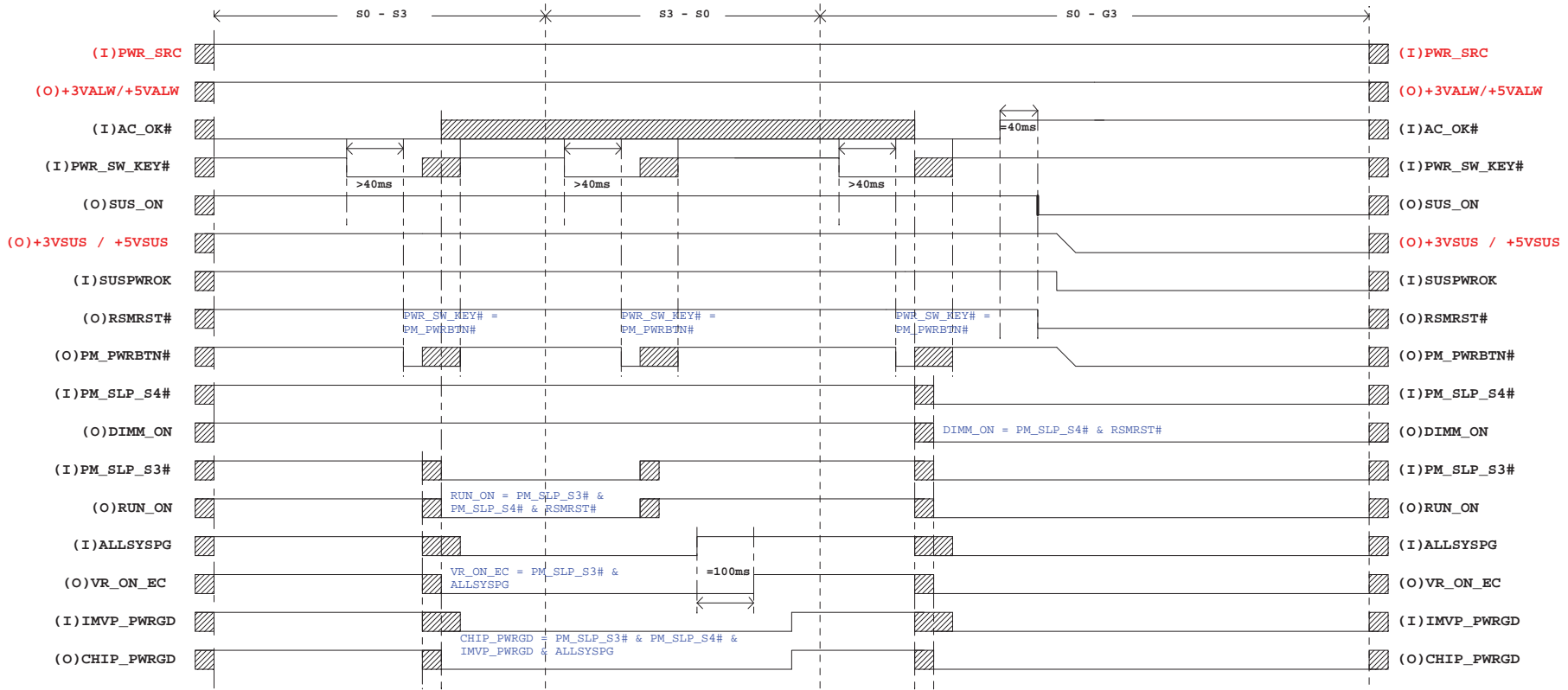

<b>MICRO-STAR INT'L CO.,LTD</b>			
<b>MS-N011</b>			
Size Custom	Document Description timing4	Rev 1.0	
Date: Friday, March 28, 2008	Sheet 38	of 39	

1. PAGE7: EC15 close to ICH7M cause RMA difficult to rework, change EC15 to C256 (1206) size.
2. PAGE21: Remove R413 & change R412 pull down to GND for LCD backlight blinking while power on.
3. Swap BT & WLAN LED.
4. PAGE25: JBAT1 pin6,7 connector to GND.
5. PAGE23: Remove CP35, CP34.
6. PAGE24: RN47 separate to R244, R254, R257. For tune LED brightness.
7. PAGE23: USB add CMC for EMI request.
8. PAGE23: Add EMC96 for EMI request.
9. PAGE26: Modify R252 value to match new 40W /20V Adapter.
9. PAGE27,29: Modify R215=9.31KR, R216=10KR, R183=5.9KR by power team.

				<b>MICRO-STAR INT'L CO.,LTD</b>			
				<b>MS-N011</b>			
Size	Custom	Document Description		History		Rev	1.0
Date:	Thursday, April 10, 2008			Sheet	39	of	39