

MLC Nand Boot 4KB Page ECC24bit 6b00110

Boot configuration	X_TEST_MODE[5:0]
MLC Nand Boot 4KB Page ECC12bit	6b001001
MLC Nand Boot 8KB Page ECC 24Bit	6b001011
SLC Nand Boot 2KB Page	6b000000
MLC Nand Boot 2KB Page ECC12bit	6b001000
MOVINAND Boot	6b001100

**东莞远峰科技有限公司**

**SF01\_V1**

Size	Document Number	Rev
Custom	AtlasV-PART A	V01

Date: Sunday, January 30, 2011      Sheet 1 of 11

U1B ATLAS-V

- X\_DF\_AD0/SD0\_DAT\_0/SD2\_DAT\_0
- X\_DF\_AD1/SD0\_DAT\_1/SD2\_DAT\_1
- X\_DF\_AD2/SD0\_DAT\_2/SD2\_DAT\_2
- X\_DF\_AD3/SD0\_DAT\_3/SD2\_DAT\_3
- X\_DF\_AD4/SD0\_DAT\_4/SD2\_DAT\_4
- X\_DF\_AD5/SD0\_DAT\_5/SD2\_DAT\_5
- X\_DF\_AD6/SD0\_DAT\_6/SD2\_DAT\_6
- X\_DF\_AD7/SD0\_DAT\_7/SD2\_DAT\_7
- X\_DF\_RY\_BY
- X\_DF\_CLE/SD0\_CLK
- X\_DF\_ALE/SD0\_CMD
- X\_DF\_RE\_B/SD2\_CMD
- X\_DF\_WE\_B/SD2\_CLK
- X\_DF\_WP\_B/SD0\_VCC\_ON
- X\_DF\_CS\_B\_1
- X\_DF\_CS\_B\_0/X\_DF\_CS\_B\_2
- X\_SD\_CMD\_3/GPIO1[3]
- X\_SD\_CLK\_3/GPIO1[2]
- X\_SD\_DAT\_3\_3/SPI\_DOUT\_0/GPIO1[10]
- X\_SD\_DAT\_3\_2/SPI\_DIN\_0/GPIO1[10]
- X\_SD\_DAT\_3\_1/SPI\_CLK\_0/GPIO1[28]
- X\_SD\_DAT\_3\_0/SPI\_LEN\_0/GPIO1[28]
- X\_SD\_DAT\_1\_3/GPIO1[15]
- X\_SD\_DAT\_1\_2/GPIO1[14]
- X\_SD\_DAT\_1\_1/GPIO1[13]
- X\_SD\_DAT\_1\_0/GPIO1[12]
- X\_SD\_CLK\_1/GPIO1[10]
- X\_SD\_CMD\_1/GPIO1[11]
- X\_SD\_WP\_B\_1/GPIO1[9]
- X\_SD\_CD\_B\_1/GPIO1[7]
- X\_SD\_VCC\_ON\_1/GPIO1[8]
- X\_AC97\_SYNC/2S\_LRCK/GPIO4[27]
- X\_AC97\_BIT\_CLK/2S\_BCLK/GPIO4[24]
- X\_AC97\_DOUT/2S\_DOUT0/GPIO4[25]
- X\_AC97\_DIN/2S\_DIN/GPIO4[26]
- X\_REF\_ADC
- X\_AUX0
- X\_AUX1
- X\_AUX2
- X\_YP
- X\_YN
- X\_XP
- X\_XN
- X\_LDD15/FD15
- X\_LDD14/FD14
- X\_LDD13/FD13
- X\_LDD12/FD12
- X\_LDD11/FD11
- X\_LDD10/FD10
- X\_LDD9/FD9
- X\_LDD8/FD8
- X\_LDD7/FD7
- X\_LDD6/FD6
- X\_LDD5/FD5
- X\_LDD4/FD4
- X\_LDD3/FD3
- X\_LDD2/FD2
- X\_LDD1/FD1
- X\_LDD0/FD0
- X\_L\_LCK/FWE\_B
- X\_L\_FCK/FOE\_B
- X\_L\_PCLK/FOE\_B1
- X\_L\_DE/FA1/GPIO3[23]

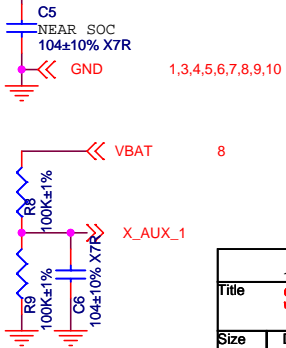
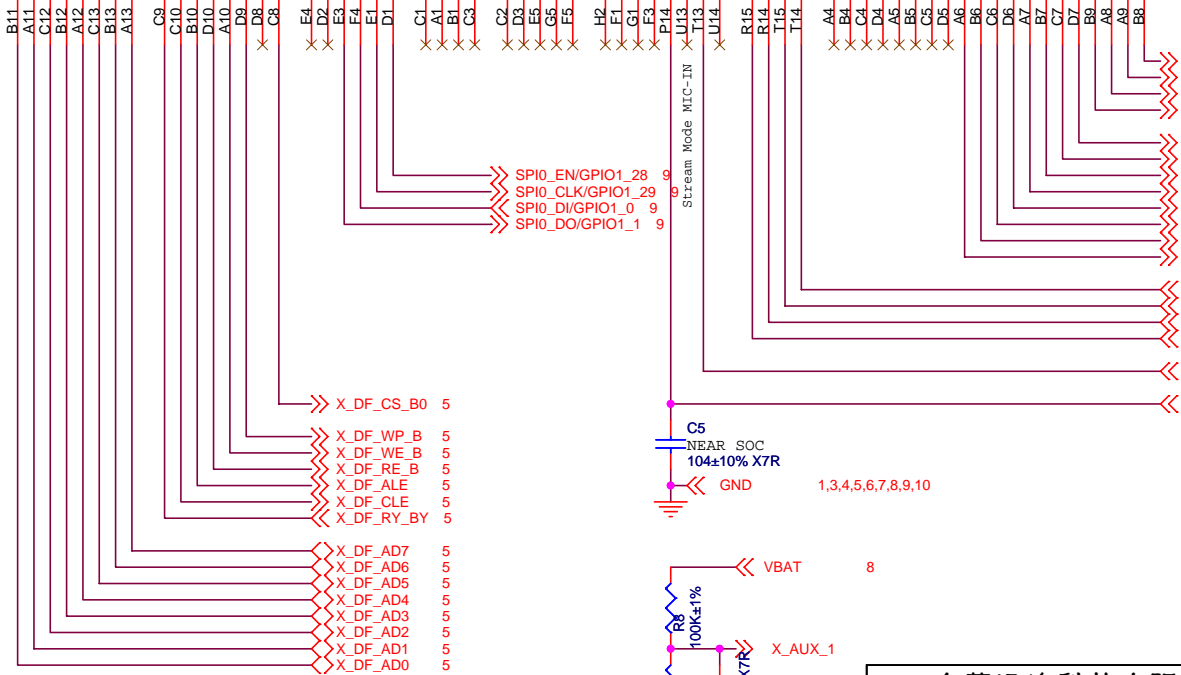

东莞远峰科技有限公司		
Title SF01_V1		
Size A	Document Number AtlasV-PART B	Rev V01
Date: Sunday, January 30, 2011	Sheet 2 of 11	

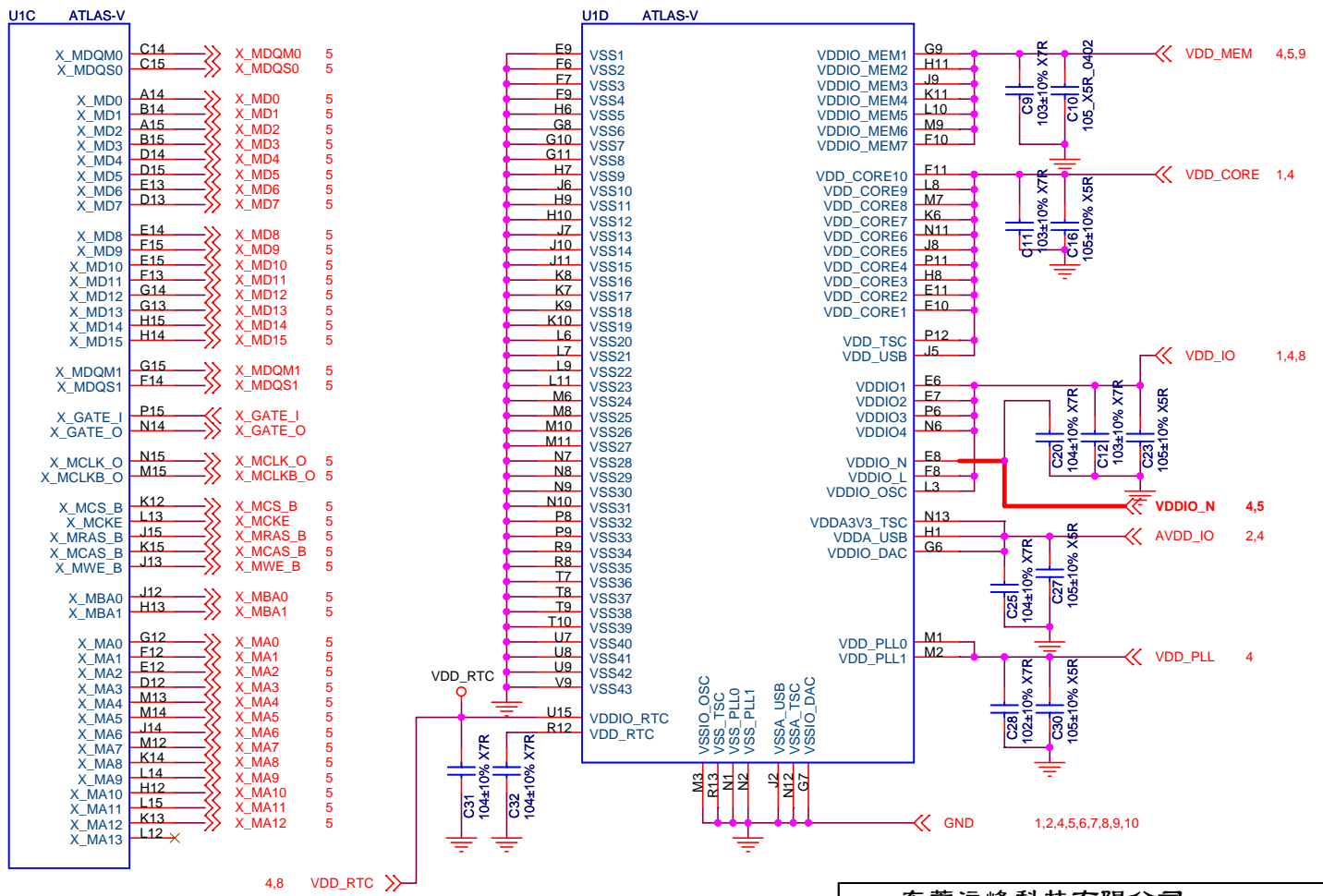

<b>东莞远峰科技有限公司</b>		
<b>SF01_V1</b>		
Size A	Document Number	Rev V01
<b>SIRF AtlasV-PART C/D</b>		
Date:	Sunday, January 30, 2011	Sheet 3 of 11

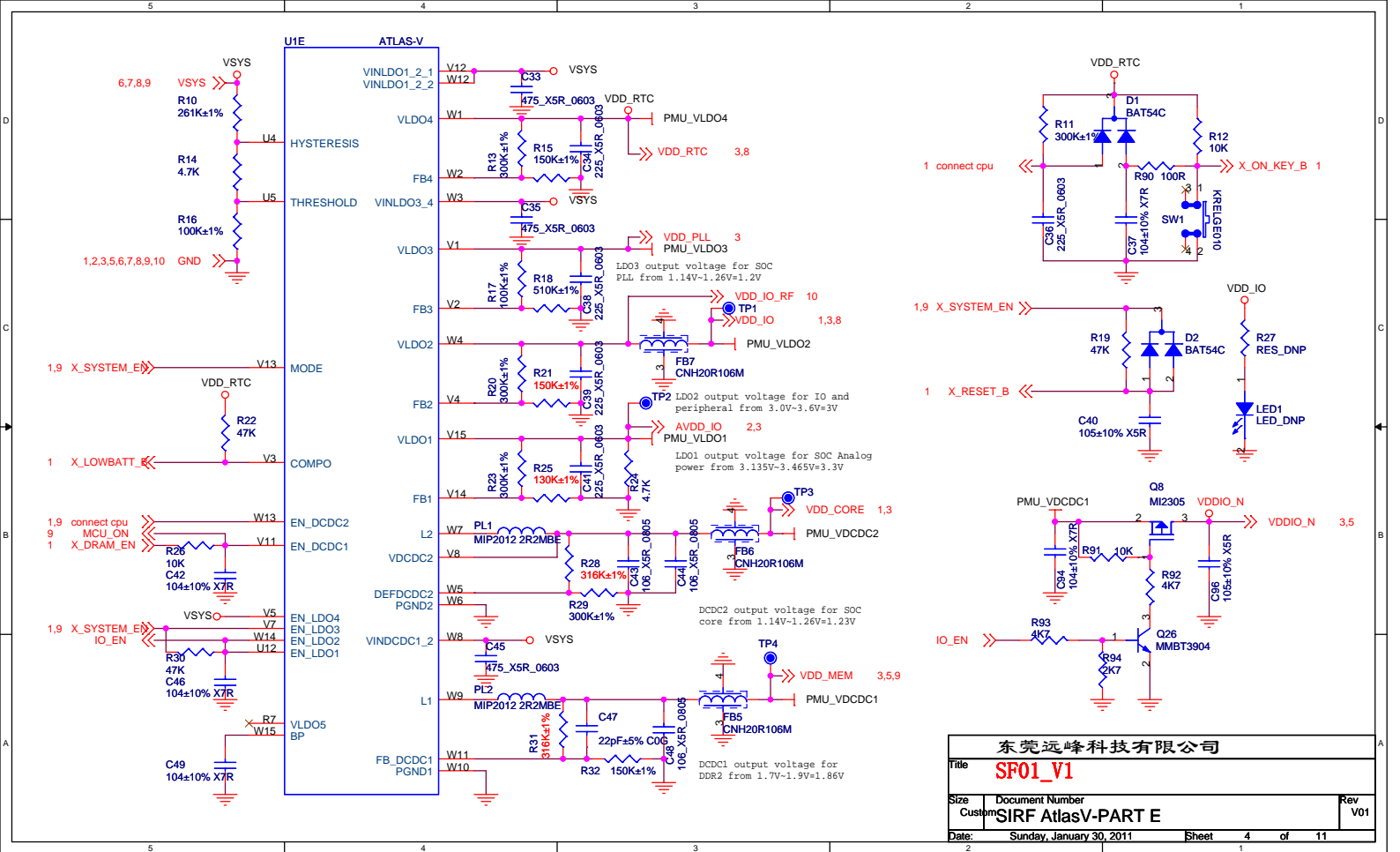

东莞远峰科技有限公司		
Title SF01_V1		
Size	Document Number	Rev
Customer	SIRF AtlasV-PART E	V01
Date:	Sunday, January 30, 2011	Sheet 4 of 11

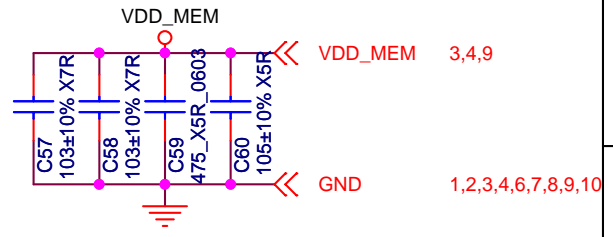
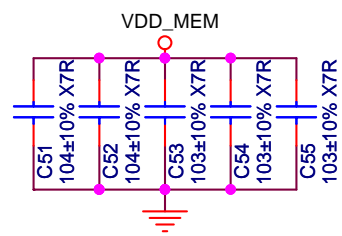
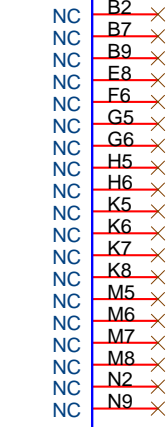
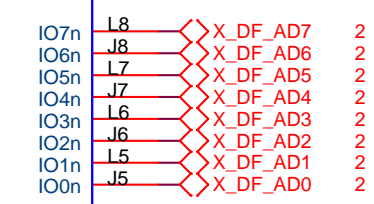
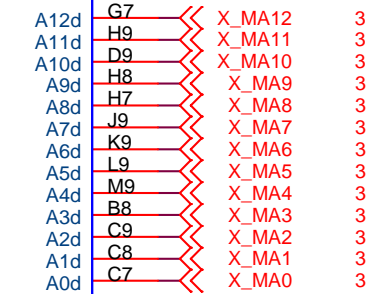
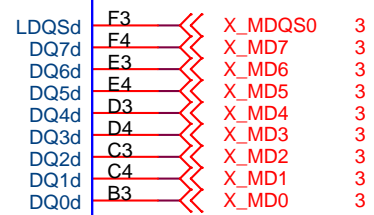
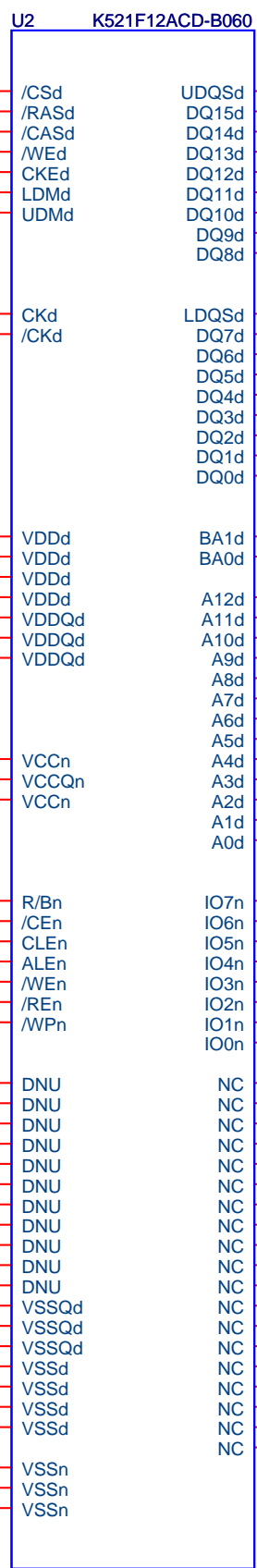
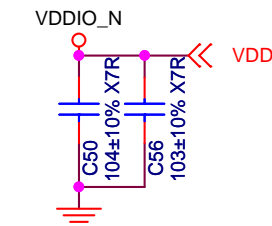
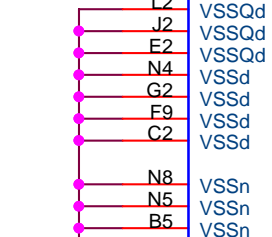
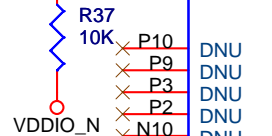
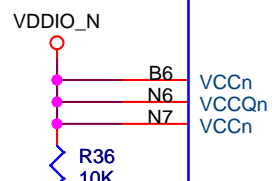
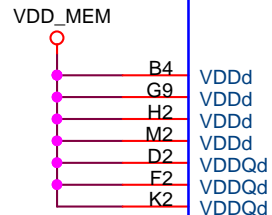
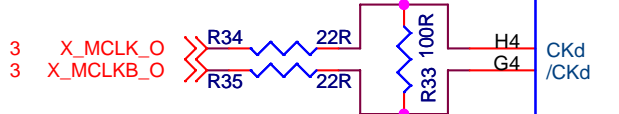

<b>东莞远峰科技有限公司</b>		
Title <b>SF01_V1</b>		
Size	Document Number	Rev
Custom	DDR-II	V01
Date:	Sunday, January 30, 2011	Sheet 5 of 11

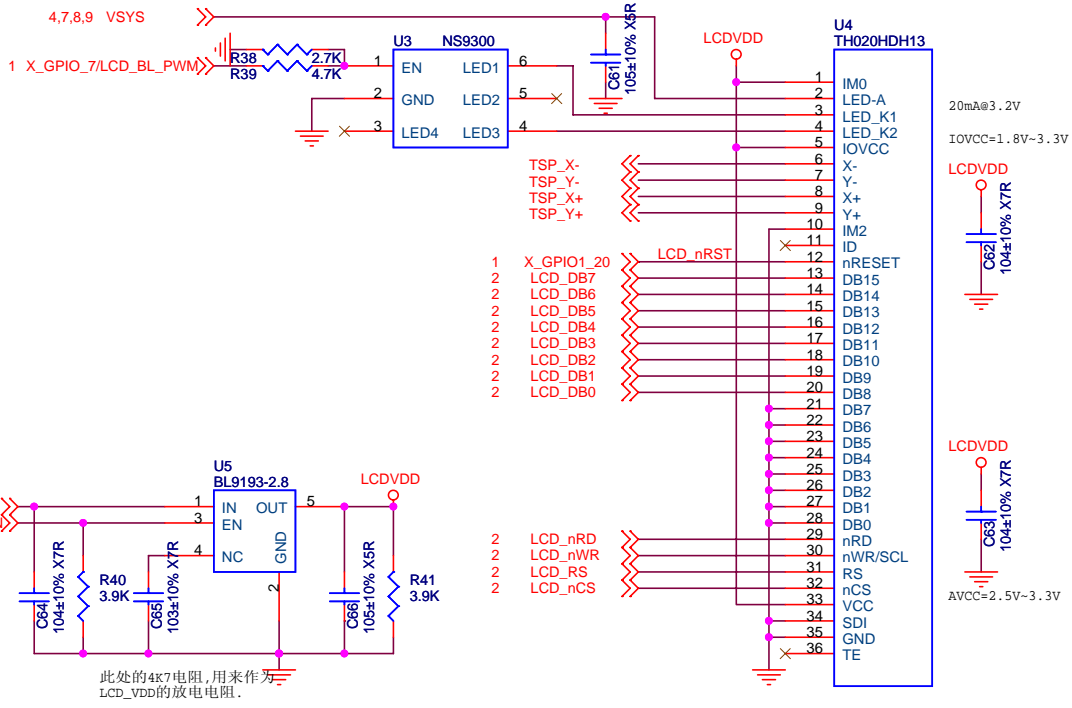

此处的4k7电阻,用来作为 LCD\_VDD的放电电阻.

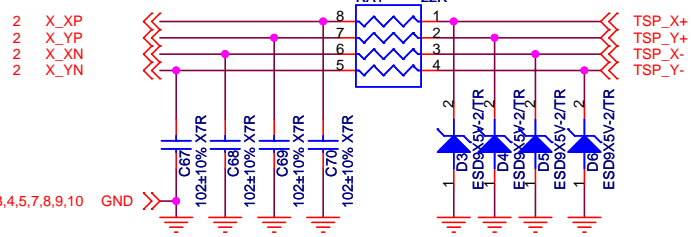
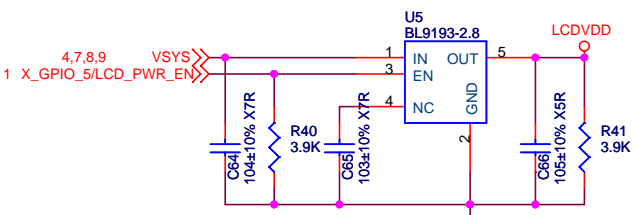

<b>东莞远峰科技有限公司</b>		
Title <b>SF01_V1</b>		
Size A	Document Number <b>QVGA TFT</b>	Rev <b>V01</b>
Date: Sunday, January 30, 2011	Sheet 6 of 11	

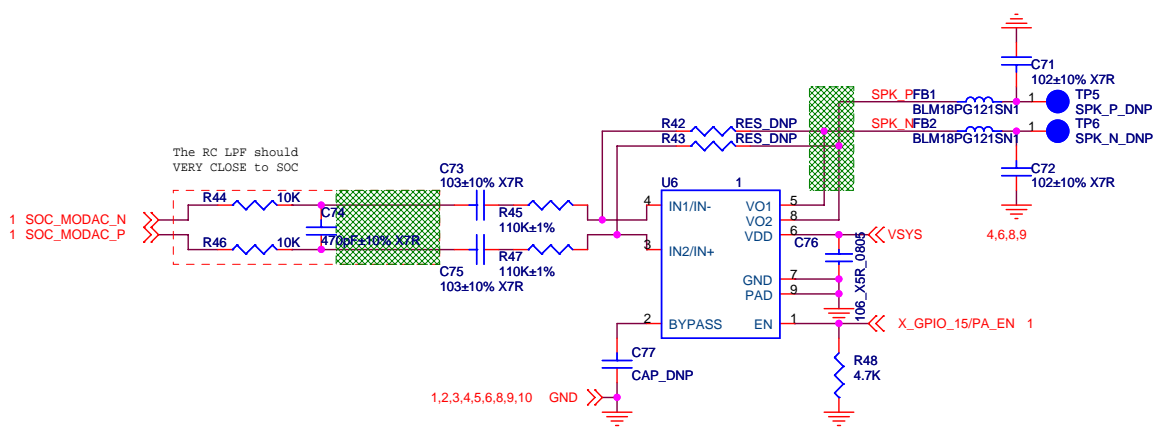

东莞远峰科技有限公司			
Title		SF01_V1	
Size	Document Number	Rev	
Custom	Audio AMP	V01	
Date:	Sunday, January 30, 2011	Sheet	7 of 11

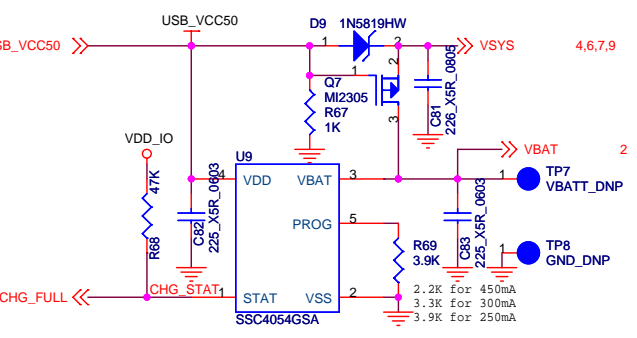
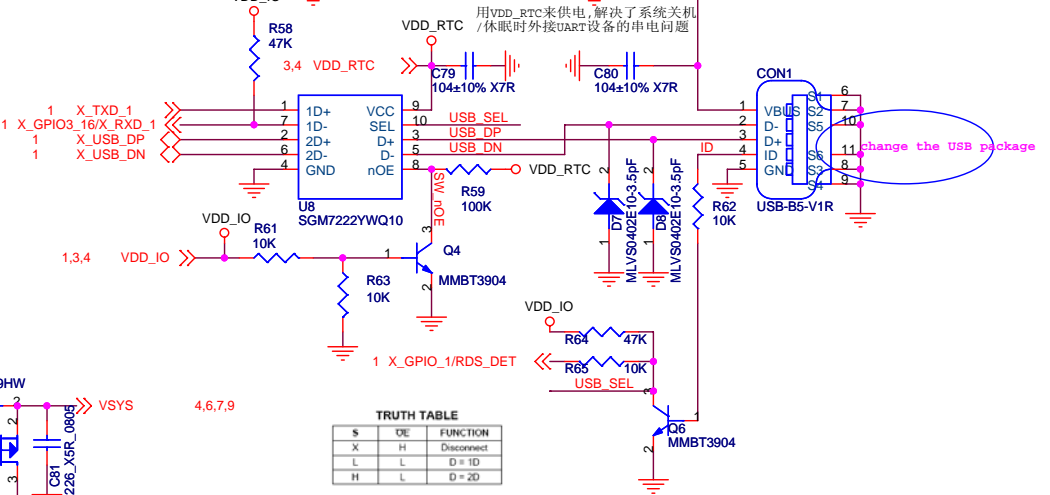
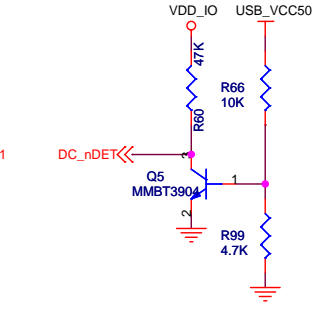
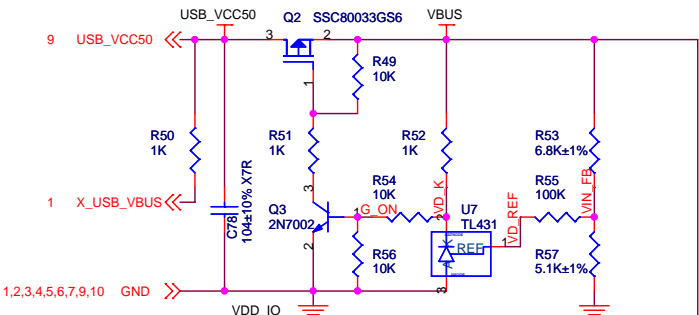
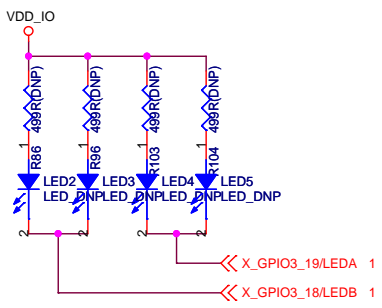

**东莞远峰科技有限公司**

**Title SF01\_V1**

Size	Document Number	Rev
Custom	DCIN/Charger	V01
Date:	Sunday, January 30, 2011	Sheet 8 of 11



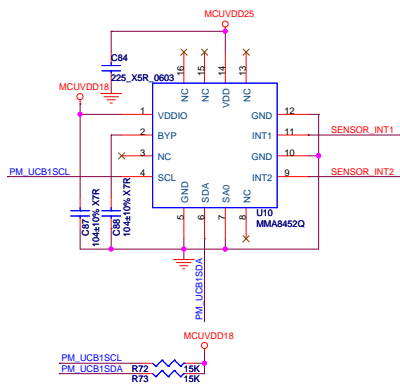

1.8V/15k=0.12mA;  
 duty cycle=50%;  
 I2C total power consume=0.12mA

3.3V(ARM VDDIO)+0.7=2.31V<2.5V(MCU VDDIO)  
 2.5V(MCU VDDIO)+0.7=1.75V<1.8V(Sensor VDDIO)

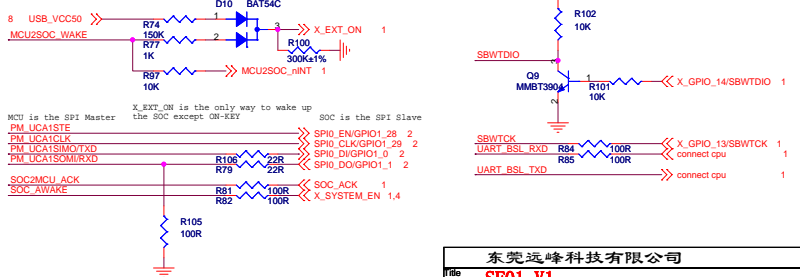
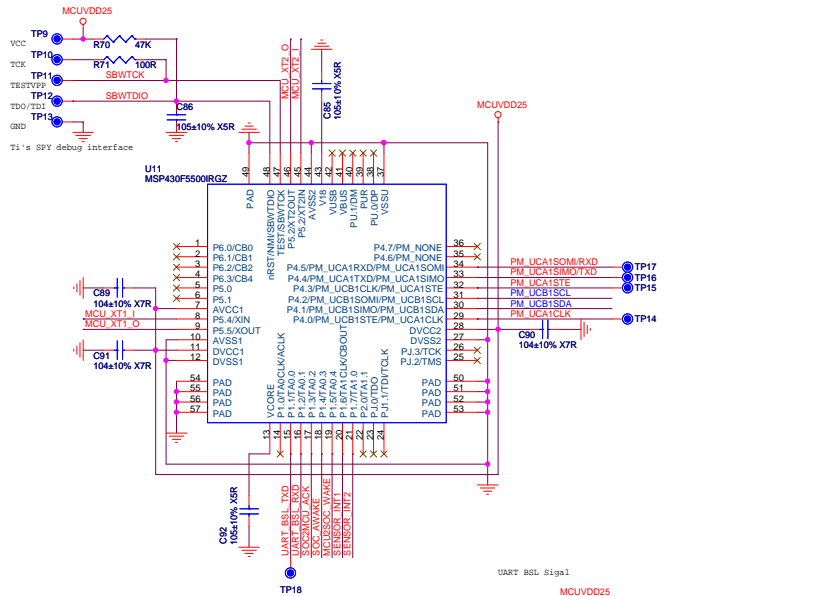
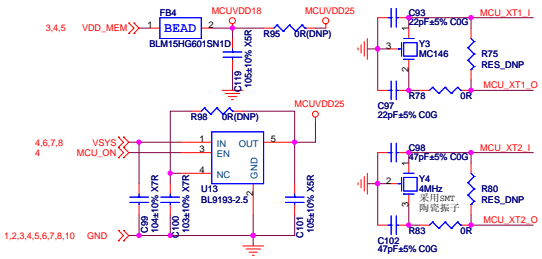

MCU is the SPI Master  
 PM\_LCA1STE  
 PM\_LCA1SMD\_TXD  
 PM\_LCA1SOM\_RXD  
 SOC2MCU\_ACK  
 SOC\_AWAKE

X\_EXT\_ON is the only way to wake up  
 the SOC except ON-KEY

SOC is the SPI Slave  
 SPI\_EN(GPIO)\_28 2  
 SPI\_CLK(GPIO)\_29 2  
 SPI\_D0(GPIO)\_0 2  
 SPI\_D1(GPIO)\_1 2  
 SOC\_ACK 1  
 X\_SYSTEM\_EN 1,4

东莞远峰科技有限公司			
File	SF01_V1		
Size	Document Number	Document Number	Rev
B	MCU		V01
Date:	Sunday, January 30, 2011	Sheet	9 of 11

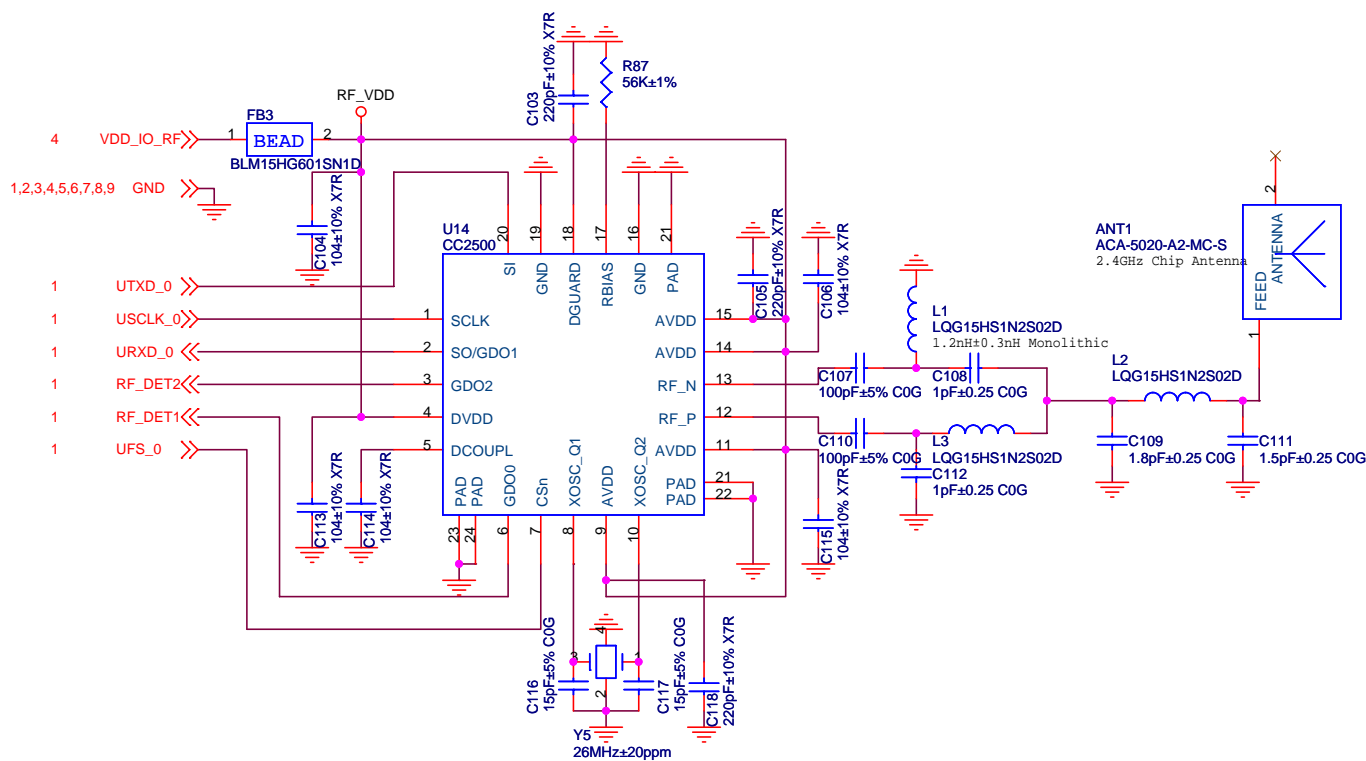

东莞远峰科技有限公司		
Title	SF01_V1	
Size	Document Number	Rev
A	2.4GHz RF	V01
Date:	Sunday, January 30, 2011	Sheet 10 of 11

5

4

3

2

1

# 光学定位点

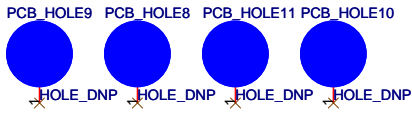
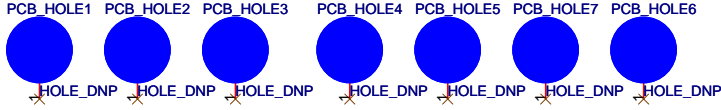
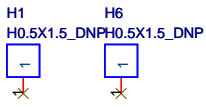
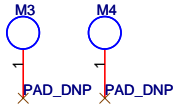

东莞远峰科技有限公司		
Title	SF01_V1	
Size A	Document Number	Rev V01
Date:	Saturday, January 29, 2011	Sheet 11 of 11