

## Micro-Power Voltage Detectors

### General Description

The RT9809 is a micro-power voltage detector supervising the power supply voltage level for microprocessors ( $\mu$ P) or digital systems. It provides internally fixed threshold levels with 0.1V per step ranging from 1.5V to 5V, which covers most digital applications. It features low supply current of 2.5 $\mu$ A.

The RT9809 performs supervisory function by sending out a reset signal whenever the VDD voltage falls below a preset threshold level. This reset signal will last the whole period before VDD recovering. Once VDD recovered up-crossing the threshold level, the reset signal will be released after a certain delay time. A 5% hysteresis splits the rising and falling threshold levels.

RT9809 is provided in SOT-23 package.

### Applications

- Computers
- Controllers
- Intelligent Instruments
- Critical  $\mu$ P and  $\mu$ C Power Monitoring
- Portable/Battery-Powered Equipment

### Ordering Information

RT9809-□□□□

- Package Type  
V : SOT-23
- Operating temperature range  
C: Commercial standard
- Reset Threshold  
15 : 1.5V  
16 : 1.6V  
:  
49 : 4.9V  
50 : 5.0V

### Features

- Internally Fixed Threshold 1.5V to 5V in 0.1V Step
- $\pm$ 2% Accuracy
- Low Supply Current 2.5 $\mu$ A
- No External Components Required
- Quick Reset within 20 $\mu$ S
- Built-in Recovery Delay 400mS
- Low Functional Supply Voltage 0.9V
- Small 3-Pin SOT-23 Package

### Pin Configurations

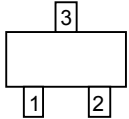
Part Number	Pin Configurations
RT9809-□□CV (SOT-23)	 <p>TOP VIEW</p> <ol style="list-style-type: none"> <li>1. GND</li> <li>2. RESET</li> <li>3. VDD</li> </ol>

### Typical Application Circuit

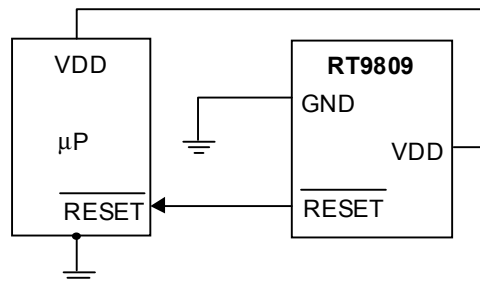

**Pin Description**

Pin Name	Pin Function
GND	Ground Pin
$\overline{\text{RESET}}$	Reset Pulse Output, Negative Pulse
VDD	Power Pin

**Function Block Diagram**

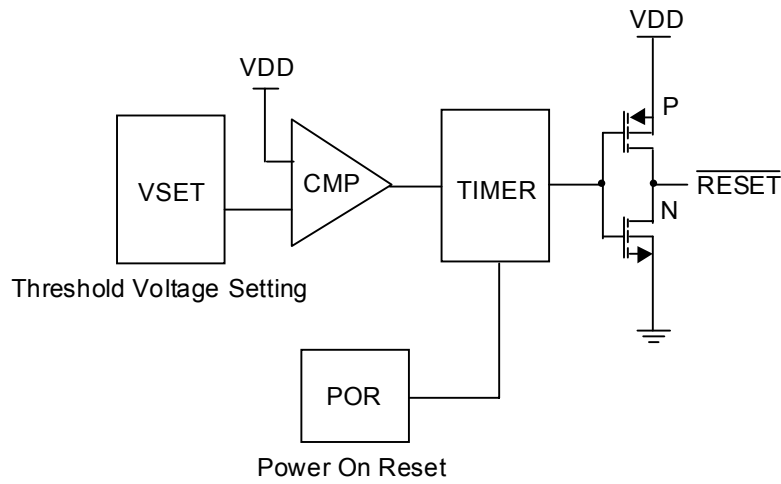

**Absolute Maximum Ratings**

- Terminal Voltage (with Respect to GND)
  - VDD ----- -0.3V to 6.0V
  - All Other Inputs ----- -0.3V to VDD+0.3V
- Input Current, VDD ----- 20mA
- Output Current,  $\overline{\text{RESET}}$  ----- 20mA
- Power Dissipation,  $P_D @ T_A = 25^\circ\text{C}$ 
  - SOT-23 ----- 0.25W
- Operating Junction Temperature Range -----  $-40^\circ\text{C} \sim 125^\circ\text{C}$
- Storage Temperature Range -----  $-65^\circ\text{C} \sim 125^\circ\text{C}$
- Package Thermal Resistance
  - SOT-23,  $\theta_{JA}$  -----  $250^\circ\text{C}/\text{W}$
- Lead Temperature (Soldering, 5sec.) -----  $260^\circ\text{C}$

**Electrical Characteristics**

(VDD = 3.0, unless specified)

Parameter	Symbol	Test Conditions	Min	Typ	Max	Units
Operating VDD ( $V_{OUT}$ ) Range	$V_{DD}$		0.9	--	6	V
Supply Current	$I_{DD}$	$V_{DD} = 1.5\text{V} \sim 5\text{V}, I_{OUT} = 0$	--	2.5	--	$\mu\text{A}$
Reset Threshold	$V_{TH}$	$T_A = 27^\circ\text{C}$	--	Note1	--	V
Threshold Voltage Accuracy	$\Delta V_{TH}$	$T_A = 27^\circ\text{C}$	--	--	2	%
VCC Drop to Reset Delay	$t_{RD}$	$V_{DD} = 5\text{V}, \text{Drop} = -20\text{mV}$	--	25	--	$\mu\text{S}$
		$V_{DD} = 1.5\text{V}, \text{Drop} = -20\text{mV}$	--	5	--	
Reset Active Time Out Period	$t_{RP}$	$V_{DD} \geq 1.02 \times V_{TH}$	--	400	--	mS
$\overline{\text{RESET}}$ Output Voltage	$V_{OH}$	$V_{DD} > V_{TH}, I_{SOURCE} > 1\text{mA}$	--	$0.8V_{DD}$	--	V
	$V_{OL}$	$V_{DD} < V_{TH}, I_{SINK} > 3.5\text{mA}$	--	$0.2V_{DD}$	--	

Note1: 1.5V ~ 5V, step 0.1V

Package Information

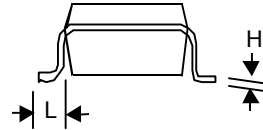
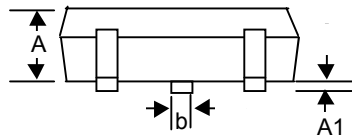
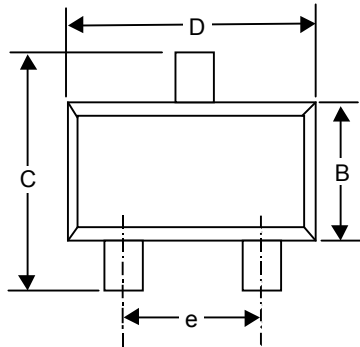

Symbol	Dimensions In Millimeters		Dimensions In Inches	
	Min	Max	Min	Max
A	0.889	1.295	0.035	0.051
A1	--	0.152	--	0.006
B	1.397	1.803	0.055	0.071
b	0.356	0.508	0.014	0.020
C	2.591	2.997	0.102	0.118
D	2.692	3.099	0.106	0.122
e	1.803	2.007	0.071	0.079
H	0.102	0.254	0.004	0.010
L	0.356	0.610	0.014	0.024

SOT-23 Plastic Surface Mount



**RICHTEK TECHNOLOGY CORP.**

Headquarter

6F, No. 35, Hsintai Road, Chupei City

Hsinchu, Taiwan, R.O.C.

Tel: (8863)5510047 Fax: (8863)5537749

**RICHTEK TECHNOLOGY CORP.**

Taipei Office (Marketing)

8F-1, No. 137, Lane 235, Paochiao Road, Hsintien City

Taipei County, Taiwan, R.O.C.

Tel: (8862)89191466 Fax: (8862)89191465

Email: [marketing@richtek-ic.com.tw](mailto:marketing@richtek-ic.com.tw)