

X=341.0 Y=222.0

REV	DATE	BY	CHKD	APPV	DESC
08					640-0232

NOTICE OF PROPRIETARY PROPERTY: THIS DOCUMENT AND THE INFORMATION CONTAINED IN IT ARE THE PROPRIETARY PROPERTY OF AMERICAN POWER CONVERSION COMPANY. IT MAY NOT BE COPIED OR USED IN ANY MANNER NOR MAY ANY OF THE INFORMATION IN OR UPON IT BE USED FOR ANY PURPOSE WITHOUT THE EXPRESS WRITTEN CONSENT OF AN AUTHORIZED AGENT OF AMERICAN POWER CONVERSION COMPANY.

APC AMERICAN POWER CONVERSION

MODEL NO. 1BM00
SCALE: NONE

REV. 08
640-0232H
SHEET 4 OF 5

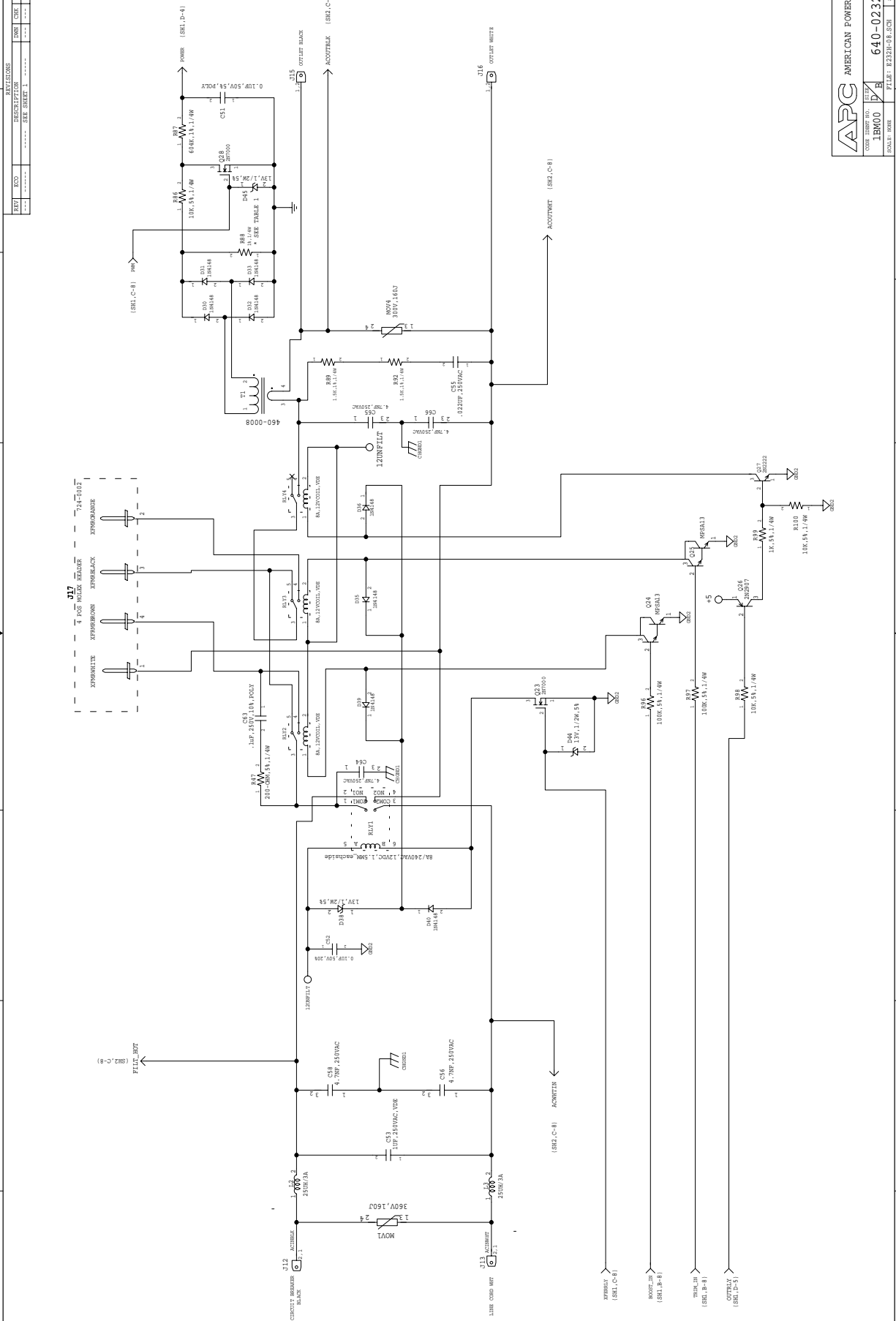

X=0 Y=0

X=3410, Y=2220

REV	NO	DESCRIPTION	CHK	DATE
08	08	640-0232		

NOTICE OF PROPRIETARY PROPERTY: THIS DOCUMENT AND THE INFORMATION CONTAINED IN IT ARE THE PROPRIETARY PROPERTY OF AMERICAN POWER CONVERSION COMPANY. IT MAY NOT BE COPIED OR USED IN ANY MANNER NOR MAY ANY OF THE INFORMATION IN OR UPON IT BE USED FOR ANY PURPOSE WITHOUT THE EXPRESS WRITTEN CONSENT OF AN AUTHORIZED AGENT OF AMERICAN POWER CONVERSION COMPANY.

APC AMERICAN POWER CONVERSION	
DATE: 12/17/00	REV: 08
PROJECT: 640-0232H	SHEET: 5 OF 5

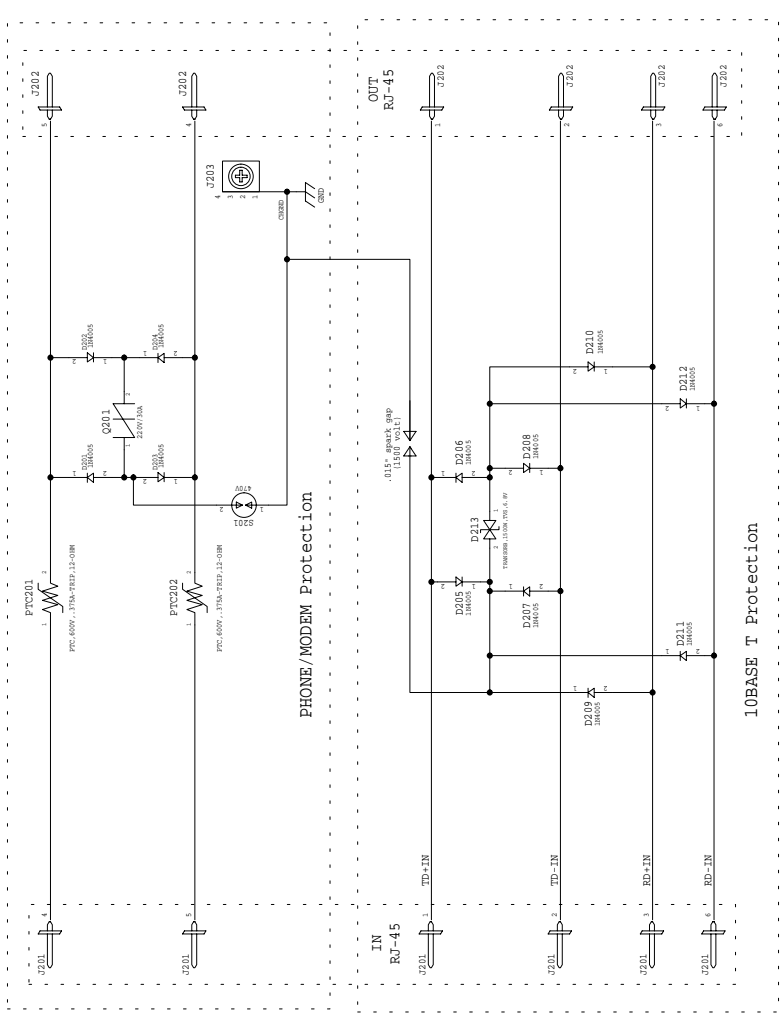

X=0, Y=0

REV	NO	DESCRIPTION	CHK	APV	DATE
1	1	REVISED			
2	2	DESCRIPTION			
3	3	SEE SHEET 1			

640-0232 08

NOTICE OF PROPRIETARY PROPERTY: THIS DOCUMENT AND THE INFORMATION CONTAINED IN IT ARE THE PROPRIETARY PROPERTY OF AMERICAN POWER CONVERSION COMPANY. IT MAY NOT BE COPIED OR USED IN ANY MANNER NOR MAY ANY OF THE INFORMATION IN OR UPON IT BE USED FOR ANY PURPOSE WITHOUT THE EXPRESS WRITTEN CONSENT OF AN AUTHORIZED AGENT OF AMERICAN POWER CONVERSION COMPANY.

AFC AMERICAN POWER CONVERSION

CODE SHEET NO. 18M00
 FILE: E232E-08.SCH SHEET 3 OF 5

