

# DATA SHEET

**TDA3629**

Light position controller

Product specification  
File under Integrated Circuits, IC18

1996 Sep 04

## Light position controller

## TDA3629

## FEATURES

- Low positional error
- Low noise sensitivity due to hysteresis
- Low supply current
- Thermally protected
- Broken wire and short-circuit indication on SET input
- Brake function by short-circuiting the motor
- Hysteresis level set externally.

## GENERAL DESCRIPTION

The Light position controller (Leucht Weiten Steller, LWS) is a monolithic integrated circuit intended to be used in passenger cars. This device adapts the elevation of the light beam of the head light of the car to a state defined by the car driver using a potentiometer on the dashboard.

## QUICK REFERENCE DATA

SYMBOL	PARAMETER	CONDITIONS	MIN.	TYP.	MAX.	UNIT
$I_{P(ss)}$	supply current, steady state	note 1	–	–	6	mA
$I_P -  I_m $	supply current, motor active	$ I_m  < 900 \text{ mA}$	–	–	80	mA
$ V_m $	output voltage	$ I_m  < 700 \text{ mA}$	$V_P - 2.9$	–	–	V
$ I_m $	output current	$V_P \geq 12.3 \text{ V}$	670	–	–	mA
$ I_{SET} $	motor switch on current level	$V_P = 12 \text{ V}$	6	9	12	$\mu\text{A}$

## Note

1. Steady state implies that the motor is not running ( $I_m = 0$ ) and  $V_{SET} = V_{FB} = 0.5V_P$ .

## ORDERING INFORMATION

TYPE NUMBER	PACKAGE		
	NAME	DESCRIPTION	VERSION
TDA3629	DIP8	plastic dual in-line package; 8 leads (300 mil)	SOT97-1
TDA3629T	SO16	plastic small outline package; 16 leads; body width 3.9 mm	SOT109-1

Light position controller

TDA3629

BLOCK DIAGRAM

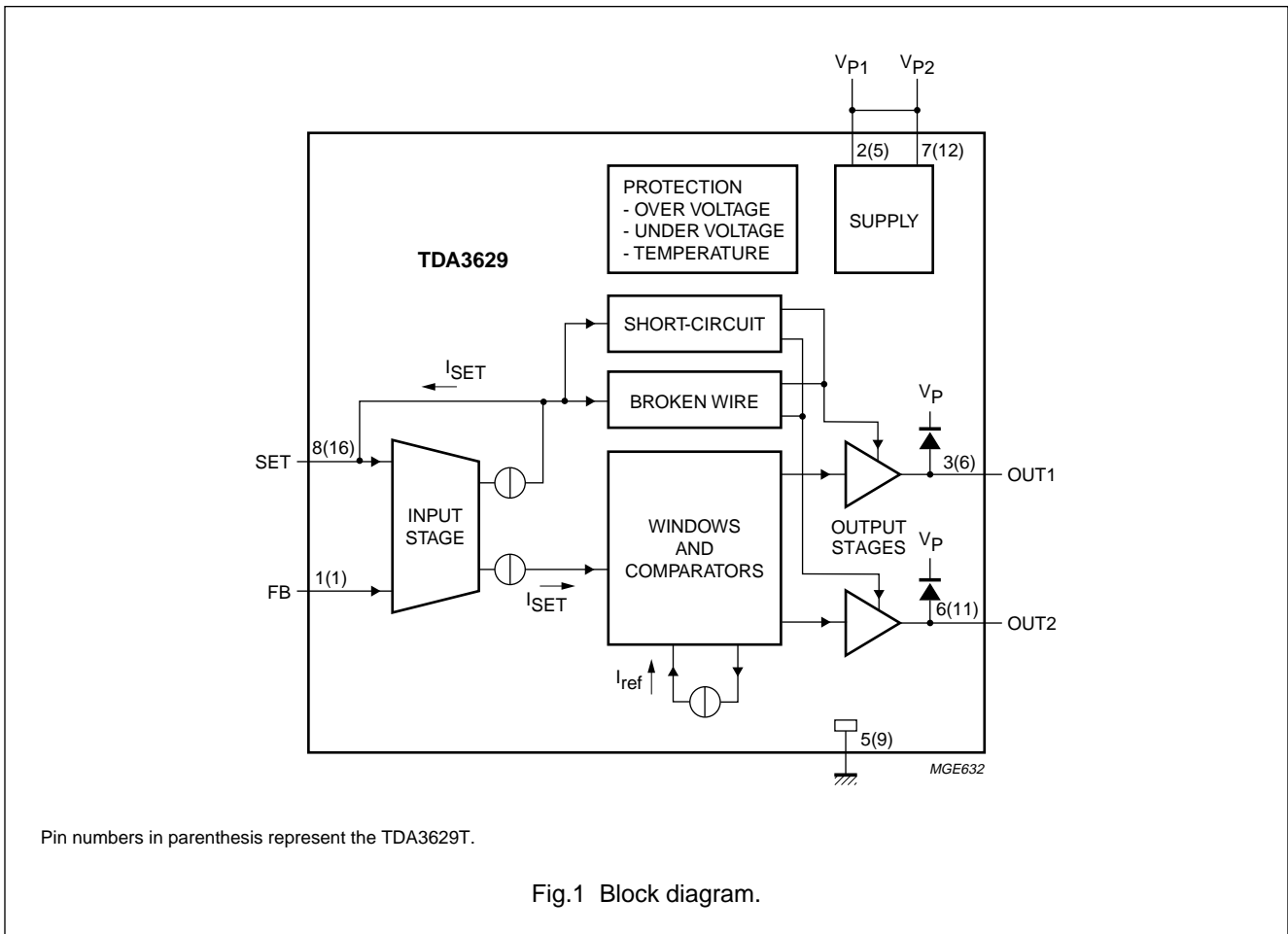

Light position controller

TDA3629

**PINNING**

SYMBOL	PIN		DESCRIPTION
	TDA3629	TDA3629T	
FB	1	1	feedback input
V <sub>P1</sub>	2	5	supply voltage 1
OUT1	3	6	output 1
n.c. <sup>(1)</sup>	4	2 to 4, 7, 8, 10, 13 to 15	not connected
GND	5	9	ground
OUT2	6	11	output 2
V <sub>P2</sub>	7	12	supply voltage 2
SET	8	16	set input

**Note**

1. The pins which are not electrically connected should be connected to a copper area of the printed-circuit board which is as large as possible to improve heat transfer.

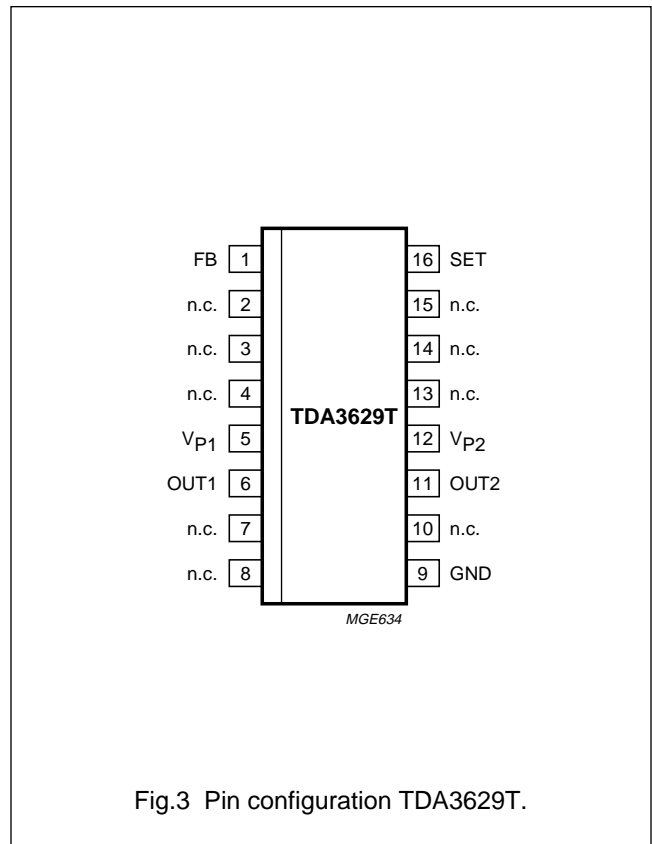
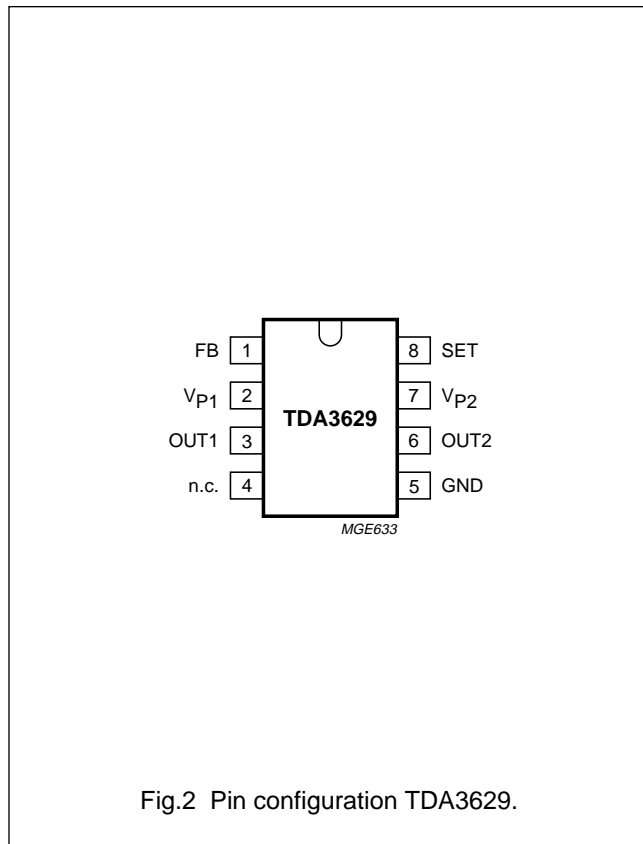

## Light position controller

TDA3629

**FUNCTIONAL DESCRIPTION**

The device is intended to control the elevation of the light beam of a head light of a passenger car. The driver can control the elevation of the light beam by rotating a potentiometer on the dashboard (the setting potentiometer). The device adapts the elevation of the light beam by activating the control motor. The elevation of the head light is fed back to the device by a second potentiometer (the feedback potentiometer). This feedback potentiometer is mechanically coupled to the motor.

The device operates only when the supply voltage is within certain limits. The device is switched off outside these boundaries. The under voltage detection detects whether the supply voltage is below the under voltage threshold. The motor will not be activated when this occurs, but it remains short-circuited by the output stages. The over voltage will switch off the total device when the supply voltage is higher than the over voltage threshold.

A thermal protection circuit becomes active if the junction temperature exceeds a value of approximately 160 °C. This circuit will reduce the motor current, which will result in a lower dissipation and hence a lower chip temperature. This condition will only occur when the motor is blocked at high ambient temperature.

A detection of a broken wire of the slider of the setting potentiometer is included because it will be connected to the device by a wire several meters long. This detection circuit prevents the motor from rotating when the wire is broken. In this event the brake will remain active.

The protection of  $V_{SET}$  to  $V_P$  circuit prevents the motor from rotating when the voltage at the  $V_{SET}$  input is above the threshold value. This can be used to detect whether the wire from the slider of the setting potentiometer is short-circuited to the battery line. A protection of  $V_{SET}$  short-circuited to ground is also present. The motor will be stopped if  $V_{SET}$  becomes lower than the threshold level. The shaded areas in Fig.4 represent the parts where the short-circuit protection stages are active. Figure 4 shows that a position of 0 mm can not be reached, neither can a position of 100%. The minimum position that can be reached depends on the battery voltage  $V_b$ , although the maximum position does not.

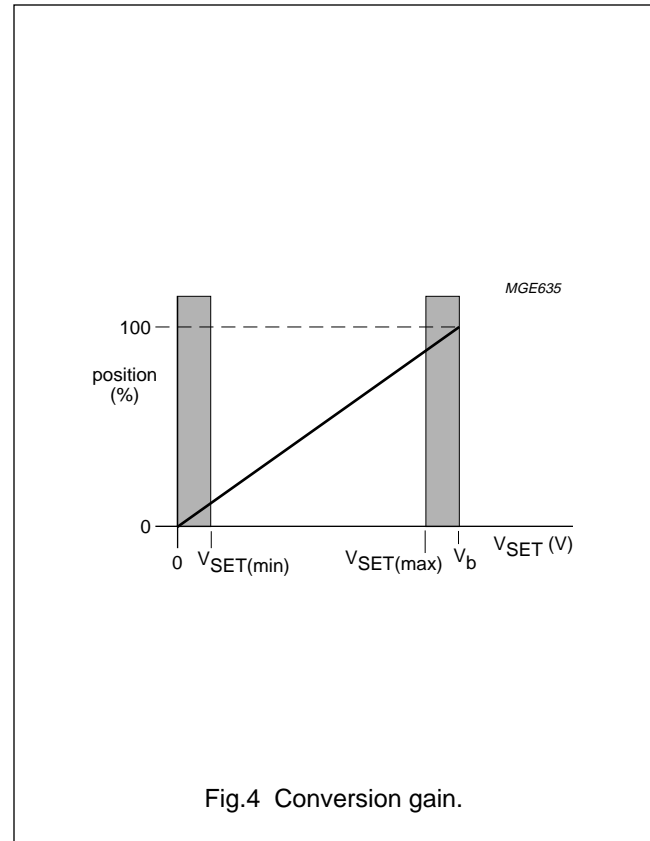

The device is protected against electrical transients which may occur in an automotive environment. The device will shut off when positive transients on the battery line occur (see Figs 7 and 8). The motor will not be short-circuited in this event. The flyback diodes, illustrated in Fig.1, will remain present. The state of the output stages at the moment when the transient starts is preserved by internal flip-flops. Negative transients on the battery line (see Figs 7 and 8) will result in a set short-circuited to ground fault detection, because it will result in a voltage at the setting input which is below the short-circuited to ground threshold. The device however discharges the electrolytic capacitor during these transients. It will stop functioning when the resulting supply voltage becomes too low.

Light position controller

TDA3629

The timing can be divided into several parts starting from a steady state (see Fig.5, the starting point, and Fig.10 for the application diagram): in this state (until  $T_1$ ) a large reference current is active, indicated by the dotted lines. When the setting potentiometer is rotated (started at  $T_1$  and indicated by  $V_{SET}$ ) and the input current  $I_{SET}$  becomes higher than the reference current  $I_{ref}$  (at time  $T_2$ ), the motor will start and the input current will decrease. At the same time the reference current is switched to a low level. During rotation of the motor the input current will decrease until it becomes lower than this low reference current;

this occurs at time  $T_4$ . At this time the brake becomes active, the motor will stop and the reference current is set to the higher value. The brake is realized by short-circuiting the motor. In general: this system does not use a linear adaptation strategy but an on-off strategy. This results in high accuracy and low noise sensitivity. The brake is active at any time during normal operation when the motor is not active. The polarity of the feedback potentiometer should be such that the voltage at the slider of the feedback potentiometer increases when OUT1 is high and OUT2 is low.

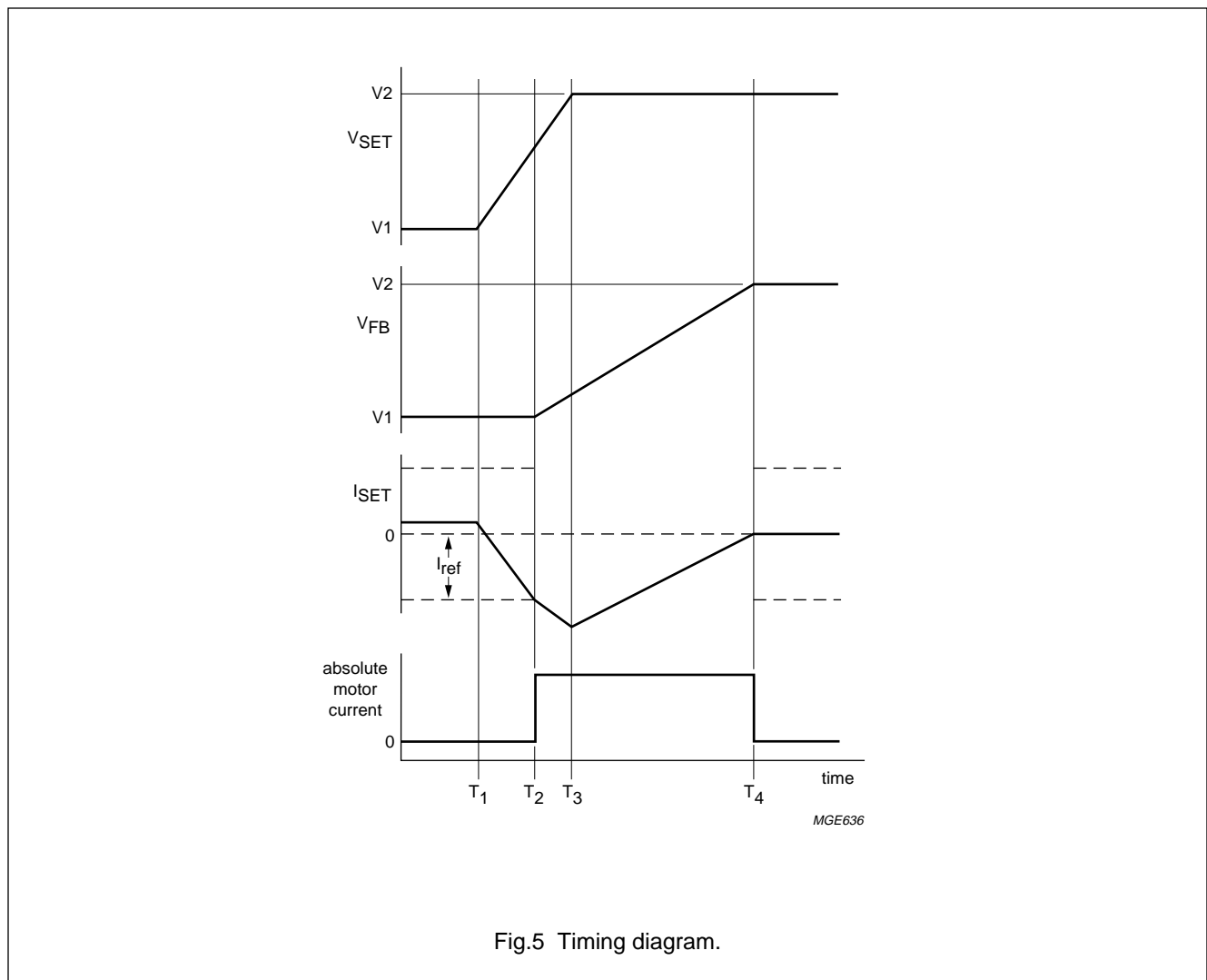

## Light position controller

## TDA3629

**LIMITING VALUES**

In accordance with the Absolute Maximum Rating System (IEC 134). All voltages are defined with respect to ground. Positive currents flow into the device. Values measured in Fig.10.

SYMBOL	PARAMETER	CONDITIONS	MIN.	MAX.	UNIT
V <sub>P</sub>	supply voltage	operating	8	18	V
		non-operating	-0.3	+50	V
V <sub>n</sub>	voltage on any other pin		-0.3	V <sub>P</sub> + 0.3	V
V <sub>es</sub>	electrostatic handling	note 1	-3	+3	kV
T <sub>stg</sub>	storage temperature		-55	+150	°C
T <sub>amb</sub>	ambient temperature		-40	+105	°C
T <sub>vj</sub>	virtual junction temperature	note 2	-50	+150	°C
V <sub>b, tr</sub>	voltage transients on V <sub>b</sub>	note 3	-150	+100	V
R <sub>L</sub>	load resistance	note 4	10	-	Ω
t <sub>block</sub>	cumulative blocking time	I <sub>m</sub>   = 700 mA	-	100	h

**Notes**

- Human body model: equivalent to discharging a 100 pF capacitor through a 1.5 kΩ resistor.
- In accordance with IEC 747-1. An alternative definition of virtual junction temperature T<sub>vj</sub> is:  
 $T_{vj} = T_{amb} + P_d \times R_{th\ vj-amb}$ , where R<sub>th vj-amb</sub> is a fixed value to be used for the calculation of T<sub>vj</sub>. The rating for T<sub>vj</sub> limits the allowable combinations of power dissipation P<sub>d</sub> and ambient temperature T<sub>amb</sub>. Additional information is given in section "Thermal aspects" in chapter "Test and application information".
- Wave forms illustrated in Figs 7 and 8 applied to the application diagram, Fig.10.
- V<sub>b</sub> = 13 V; T<sub>amb</sub> = 25 °C; duration 50 ms maximum; non repetitive.

**THERMAL CHARACTERISTICS**

In accordance with IEC 747-1.

SYMBOL	PARAMETER	VALUE	UNIT
R <sub>th vj-amb</sub>	thermal resistance from junction to ambient in free air		
	TDA3629	100	K/W
	TDA3629T	105	K/W

## Light position controller

## TDA3629

**CHARACTERISTICS**

$V_P = 12\text{ V}$ ;  $R_L = 14\ \Omega$ . All voltages are defined with respect to ground. Positive currents flow into the device. Values measured in Fig.10 with  $R_{SET} = R_{FB} = 20\text{ k}\Omega$ ; unless otherwise specified.

SYMBOL	PARAMETER	CONDITIONS	MIN.	TYP.	MAX.	UNIT
<b>Supply</b>						
$V_{P(min)}$	under voltage threshold		6	–	8	V
$V_{P(max)}$	over voltage threshold	$T_{amb} = 25\text{ }^\circ\text{C}$	18	–	22	V
		$T_{amb} = -40\text{ to }+105\text{ }^\circ\text{C}$	17.5	–	22.8	V
$I_{P(ss)}$	supply current, steady state	note 1	–	–	6	mA
$I_P -  I_m $	supply current, motor active	$ I_m  < 400\text{ mA}$ ; note 2	–	–	40	mA
		$ I_m  < 900\text{ mA}$ ; note 2	–	–	80	mA
<b>Setting input (SET)</b>						
$V_{SET}$	operating voltage		1.5	–	$0.95V_P$	V
$I_{SET}$	input current	$R_{SET} > 20\text{ k}\Omega$	–250	–	+250	$\mu\text{A}$
$V_{SET(sc)}$	wire short-circuited to ground threshold	output stages switched off	–	–	1	V
	wire short-circuited to battery threshold	output stages switched off	$V_P$	–	–	V
$\Delta V_{SET}$	broken ground set pull-up	note 3	–	–	160	mV
<b>Feedback input (FB)</b>						
$V_{FB}$	voltage		1.5	–	$0.95V_P$	V
$I_{FB(max)}$	maximum input current	$R_{FB} > 20\text{ k}\Omega$	–250	–	+250	$\mu\text{A}$
<b>Motor outputs</b>						
$ V_m $	output voltage	$ I_m  < 700\text{ mA}$ ; $T_{amb} = 25\text{ }^\circ\text{C}$ ; note 2	$V_P - 2.9$	–	–	V
		$ I_m  < 700\text{ mA}$ ; $T_{amb} = -40\text{ to }+105\text{ }^\circ\text{C}$ ; note 2	$V_P - 3.4$	–	–	V
$ I_m $	output current	$V_P \geq 12.3\text{ V}$ ; $T_{amb} = 25\text{ }^\circ\text{C}$ ; note 2	670	–	–	mA
		$V_P \geq 12.3\text{ V}$ ; $T_{amb} = -40\text{ to }+105\text{ }^\circ\text{C}$ ; note 2	635	–	–	mA
<b>Reference current</b>						
$ I_{SET} $	motor switch-on level	$V_P = 12\text{ V}$	6	9	12	$\mu\text{A}$
		$V_P = 18\text{ V}$	9	13	17	$\mu\text{A}$
	motor switch-off level		–	2.5	–	$\mu\text{A}$



## Light position controller

## TDA3629

**Notes to the characteristics**

1. Steady state implies that the motor is not running ( $I_m = 0$ ) and  $V_{SET} = V_{FB} = 0.5V_p$ .
2. This is only valid when the temperature protection is not active.
3.  $\Delta V_{SET}$  is the difference in voltage on the set potentiometer between the situation when the ground wire is interrupted ( $V_{SET, br}$ ) and voltage on the set potentiometer during normal operation (when  $V_{SET} = 0.17V_b = 2.72$  V).  
The conditions for this test are:  
 $R_{SET} = 20$  k $\Omega$ ;  $V_b = 16$  V;  $\Delta V_{SET} = V_{SET, br} - 2.72$  V; see Fig.6.

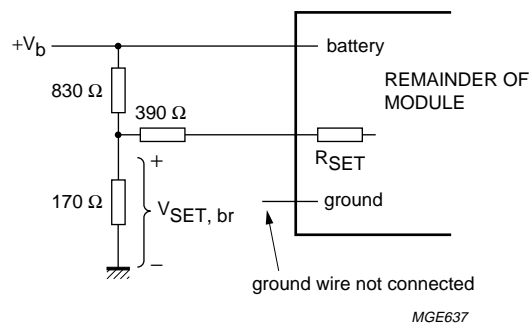

The 170  $\Omega$ , 830  $\Omega$  and 390  $\Omega$  resistors form the setting potentiometer in its worst case position. The given situation (combination of  $V_b$ ,  $R_{SET}$  and the position of the set potentiometer) forms the worst case situation. The given maximum of  $\Delta V_{SET}$  guarantees that any other module, connected to the same set potentiometer, will not start to activate its motor, when its motor switch-on level is higher than  $0.01V_b$  ( $R_{SET} \geq 20$  k $\Omega$ ).

Fig.6 Conditions for the test of note 3.

**QUALITY SPECIFICATION**

The quality of this device is in accordance with "SNW-FQ-611 part E". The numbers of the quality specification can be found in the "Quality reference Handbook". The handbook can be ordered using the code 9397 750 00192.

Light position controller

TDA3629

TEST AND APPLICATION INFORMATION

Automotive transients

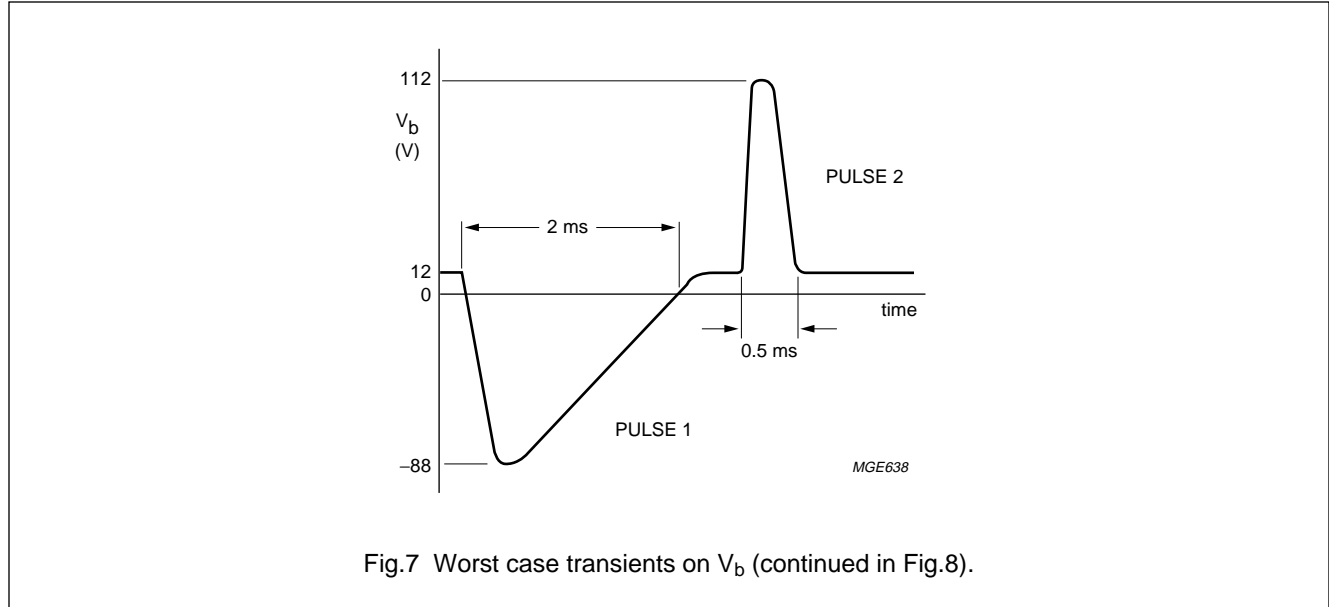

Worst case transients that may occur on the battery line  $V_b$  of the application (see Fig.10), are the pulses whose wave forms and the corresponding values are as illustrated in Figs 7 and 8. The signal source which generates these pulses (numbered pulses 1 and 2) has a series resistance ( $R_i$ ) of  $10 \Omega$ . These pulses represent for instance the influence of switching of inductors on the battery line. The signal source which generates pulses 3 and 4 has a series resistance of  $50 \Omega$ . These pulses represent for instance the influence of ignition on the battery line. Their repetition rate is 100 ms.

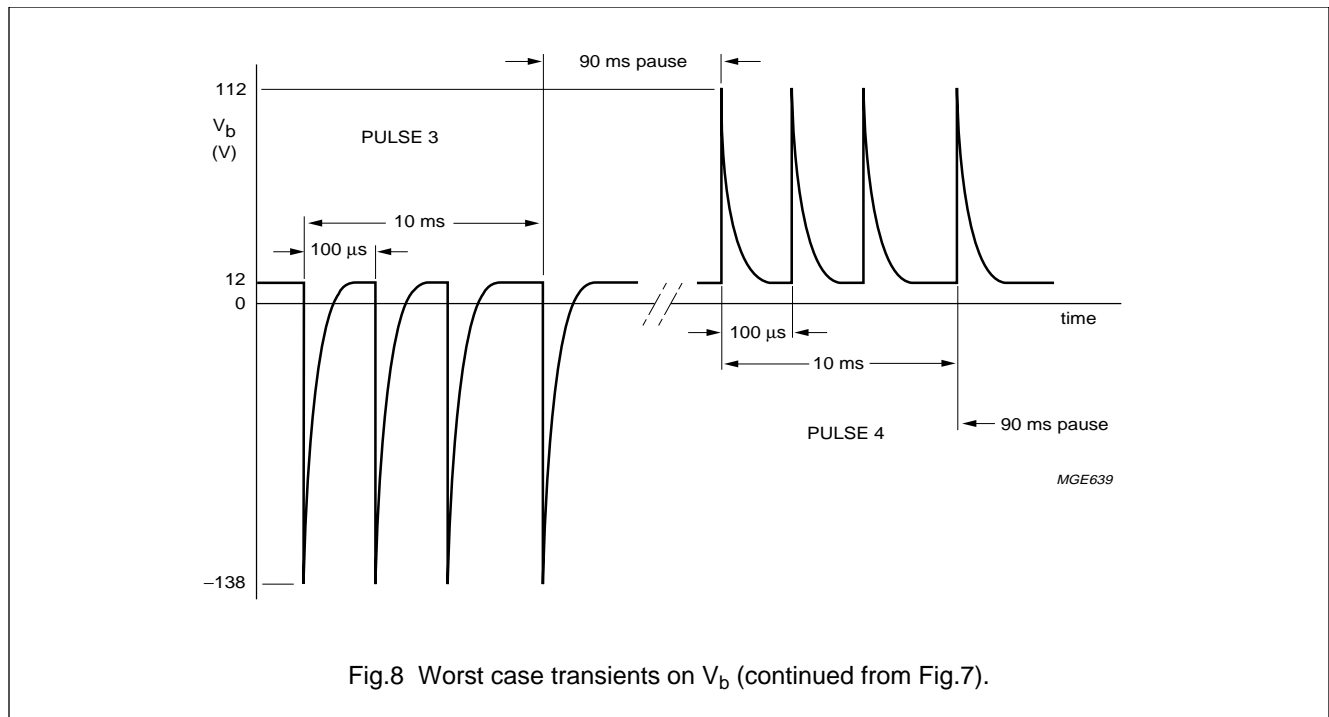

# Light position controller

# TDA3629

### Application diagrams and additional information

Two possible application diagrams are shown. The first (see Fig.9) shows the best case: the lowest component count. The second (see Fig.10) shows additional components which may be necessary. Two capacitors are added to meet EMC requirements (one on the  $V_P$  pins, the second one between the set and feedback input pins). A third capacitor has been added across the motor to suppress current spikes. The given values of these capacitors have to be optimized by experiments carried out on the total application. The resistors do not have to have the same value. The voltage hysteresis is set by means of  $R_{SET}$ .

The resistor in the feedback input line ( $R_{FB}$ ) is present to limit the current during the transients as illustrated in Figs 7 and 8. This resistor should have a value larger than  $2\text{ k}\Omega$ .  $R_{SET}$  can be chosen freely but must also be larger than  $2\text{ k}\Omega$ . A diode is placed in series with the supply line in both applications to protect the device from reverse polarity switching and from damage caused by pulses 1 and 3 in Figs 7 and 8. In the present application a varistor is included in the motor. The electrolytic capacitor of  $47\text{ }\mu\text{F}$  should have a very low ESR, for instance as low as  $5\text{ }\Omega$  at a temperature of  $-40\text{ }^\circ\text{C}$ . An extra ceramic capacitor (approximately  $100\text{ nF}$ ) parallel to it is obligatory when this can not be guaranteed.

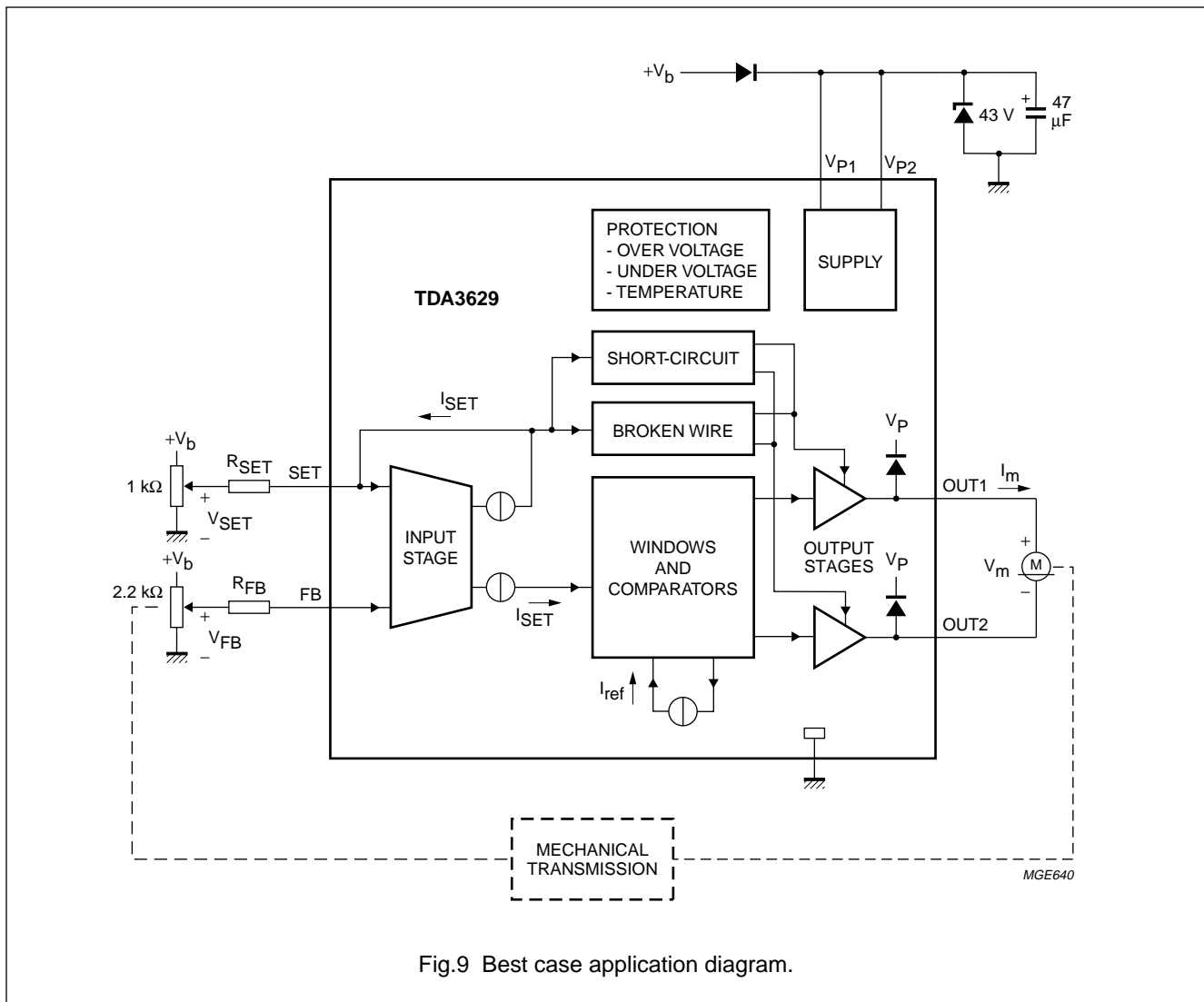

Light position controller

TDA3629

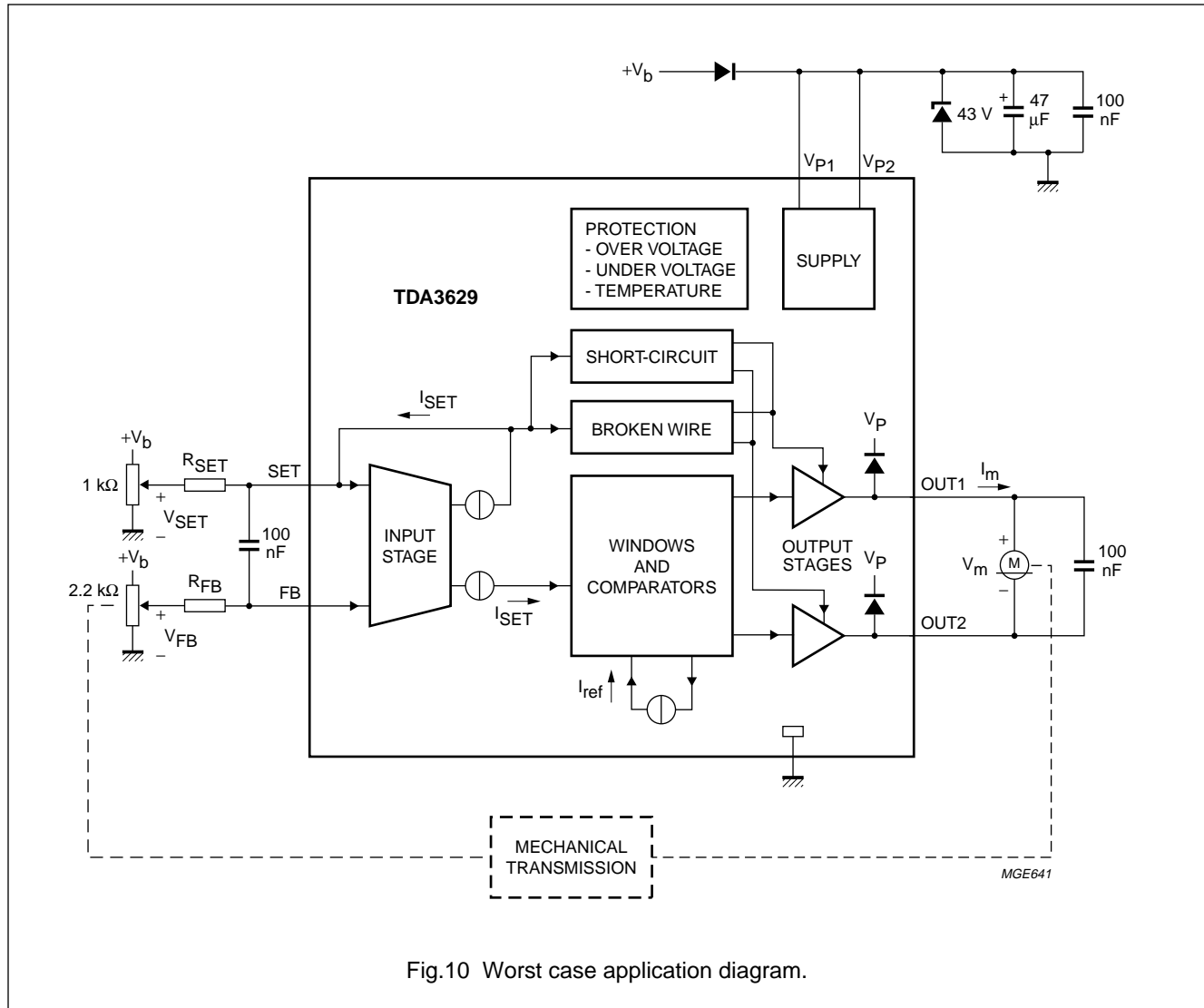

Fig.10 Worst case application diagram.

**Thermal aspects**

The dissipation of the device is the sum of two sources: the supply current ( $I_P - |I_m|$ ) times the supply voltage ( $V_P$ ) plus the motor current ( $|I_m|$ ) times the output saturation voltage ( $V_P - |V_m|$ ). In formula:

$$P = V_P \times (I_P - |I_m|) + |I_m| \times (V_P - |V_m|)$$

$(I_P - |I_m|)$  is approximately equal to  $I_{P(ss)}$  when the motor is not running. It is obvious from the ratings that the combination of  $V_P = 18\text{ V}$ ,  $(I_P - |I_m|) = 80\text{ mA}$ ,  $|I_m| = 900\text{ mA}$  and  $(V_P - |V_m|) = 2.5\text{ V}$  can not be allowed at  $T_{amb} = 105\text{ °C}$ ; see chapter "Limiting values" note 2. But it is also improbable that the motor is continuously driven, therefore the following assumptions have been made.

It is assumed that the device must be capable of moving the motor from one end to the other in four equal steps and that the total time needed for this excursion is 16 seconds. After this excursion a pause is allowed before the same pulses are used to return to the original position. This operation is illustrated in Fig.11.

# Light position controller

# TDA3629

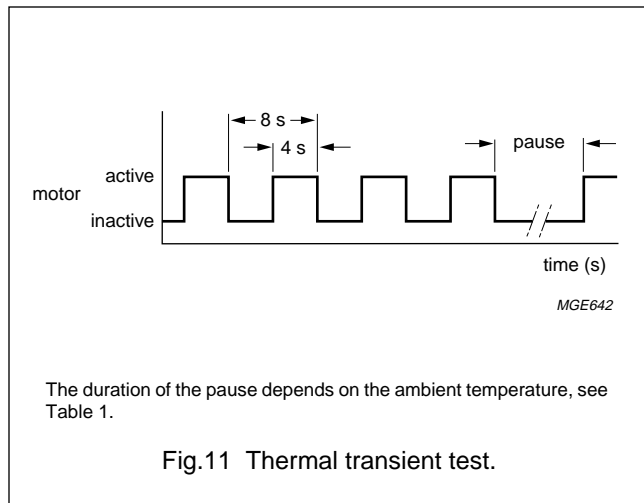

Fig.11 Thermal transient test.

**Table 1** Duration of the pauses

T <sub>amb</sub> (°C)	PAUSE (s)
<95	60
95	180
95 to 105	300

The maximum allowable dissipated power P is then 0.77 W during the motor active periods in the event of a DIP8 package being used. Dissipation pulses due to starting and stopping the motor can be ignored because of their short duration. This maximum allowable dissipated power implies that the maximum continuous motor current ( $|I_m|$ ) is approximately 250 mA during the motor active periods when the supply voltage  $V_P$  is 13 V. The maximum allowable dissipated power P is 0.67 W during the motor active periods in the event of a SO16 package being used. This implies that the maximum continuous motor current ( $|I_m|$ ) is approximately 220 mA during the motor active periods when the supply voltage ( $V_P$ ) is 13 V.

### Stereo operation

The default application will be when two modules are driven by one set potentiometer. One module controls the left head light, where the other one controls the right head light. Each module is connected by three wires: the battery line, the ground line and the set input wire. This can result in two additional fault conditions: from one module the battery line or the ground line can be broken, when the other module is still connected. Assume that the left one operates normally, where the right one has a fault. The setting potentiometer will have extra loading when the battery line is broken. This will result in a lower voltage at the wiper of the setting potentiometer. Thus the left module will start to regulate until a new equilibrium is reached. The amount of extra loading can be influenced by the external series resistor in the set input. These fault conditions and their implications should be considered when the total application is designed.

### Test diagram

All parameters in chapter "Characteristics" until this section are measured at  $T_{amb} = 25\text{ °C}$  and are tested at each device using the test set-up of Fig.12. The only exceptions are parameters supply current (motor active) and output voltage (motor output) where the 1 kΩ output resistor is replaced by an appropriate current source.

Light position controller

TDA3629

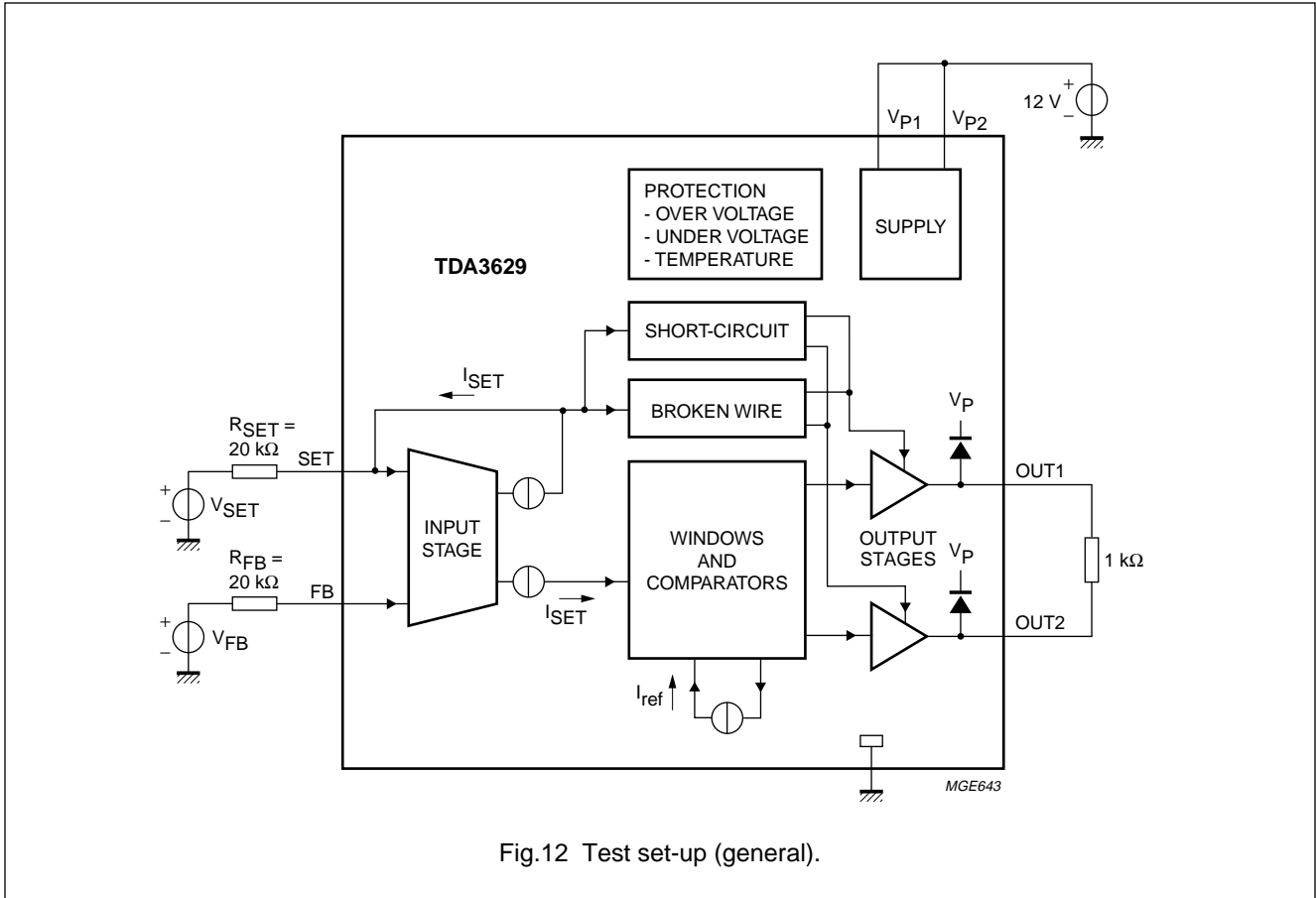

Fig.12 Test set-up (general).

## Light position controller

## TDA3629

### IMMUNITY TO NARROW BAND ELECTROMAGNETIC DISTURBANCES

#### Test procedure

##### GENERAL INFORMATION

The immunity is measured using a test procedure, which is derived from the draft international standard "ISO/DIS 11452", parts 1 and 7, submitted for circulation 1992 June 14.

The test is carried out using a printed-circuit test board in a test set-up, which is illustrated in Fig.13. The circuit diagram of the test board is shown in Fig.14. The physical layout of the test board is shown in Figs 15 to 17.

##### PREPARATION OF TEST

The IC under test is mounted onto the printed-circuit test board. The printed-circuit test board is mounted into the faraday cage (RF-shielded 19 inch-rack) and connected to the test equipment as shown in Fig.13. One of three RF voltage injection points has to be chosen for injection, while the others have to be connected to passive terminations. The injection into the control loop via input RFC is shown in Fig.13.

After the set-up is completed, the feedback voltage is selected by the appropriate setting of a jumper in the jumper field J1 (see Fig.14) and the battery voltage is switched on. With no RF voltage injected the correct operation of the system is verified by turning the SET potentiometer (see Fig.13) left and right (or vice-versa). The outputs OUT1 and OUT2 will switch to on-state (absolute differential voltage  $V_{diff} = 3$  to 5 V DC) in both turn directions. If the device under test functions correctly, the potentiometer is set to a position where the absolute voltage difference between the slider connection of the potentiometer and the jumper J1 is less than 5 mV. After adjustment, the absolute differential output voltage  $V_{diff}$  has to be below 100 mV. Having reached this condition the immunity test may be started.

##### TEST OF IMMUNITY

For the test of immunity the RF voltage is injected into the test board and  $V_{diff}$  is monitored for degradation.  $V_{diff}$  is degraded if its actual value exceeds the maximum value described in Table 2. In the test routine the frequency is varied in steps from the start frequency to the stop frequency (see Table 2). Within each frequency step the level of injected RF voltage is incremented by steps to the maximum test level, which is specified in Table 2. Each step level is held constant for the dwell time. After the dwell time has elapsed, the degradation of the absolute output voltage is checked. If a degradation is detected it

has to be verified, because the level setting may have an overshoot and the device under test may have a latching behaviour. The verification is achieved by switching off the power supply for 1 s after degradation is first detected. Then the supply is switched on and the degradation is rechecked. If the second check also indicates a degradation, then the values of RF level and frequency are inserted into a data file for reporting. If the second check is negative the level is further increased.

If no degradation occurs until the specified maximum test level is reached, the maximum level is recorded together with the frequency of that step.

##### RECOMMENDED RF-VOLTAGE SETTING PROCEDURE

For a fast setting of the RF voltage to the required test level step it is recommended that the substitution method is used.

This method sets the actual test level with respect to level values that have been filed in a pre-measurement.

The RF source in the test set-up is built from a low-power RF generator and suitable amplifiers. In the recommended pre-measurement the RF voltage at the injection point is measured, while the signal generator outputs a constant voltage level (e.g. 100 mV). Thus, the gain factor from the output of the RF generator to the injection point can be easily calculated.

In the pre-measurement the RF voltage at the injection point is measured for each frequency step. Dividing this measured voltage by 100 mV results in the gain factor for this frequency. All gain factors together with their frequency value are filed for use in the level setting of the immunity tests.

In the immunity test routine, a required RF voltage test level at a frequency step is obtained by setting the RF signal generator to a level that is calculated by dividing the required RF voltage test level by the gain factor of that frequency.

##### Test conditions

The test is carried out using the test procedure as mentioned before and under the conditions mentioned in Table 2.

## Light position controller

## TDA3629

**Table 2** General test conditions for immunity measurements

SYMBOL	PARAMETER	CONDITIONS	MIN.	TYP.	MAX.	UNIT
<b>General</b>						
T <sub>amb</sub>	ambient temperature		18	–	28	°C
V <sub>bat</sub>	battery voltage		12.5	–	13.5	V
V <sub>diff</sub>	absolute differential output voltage (DC value)			0	1.0	V
f <sub>start</sub>	start frequency		–	250	–	kHz
f <sub>stop</sub>	stop frequency		–	1 000	–	MHz
f <sub>n</sub>	frequency steps	from 250 kHz to 1 MHz	–	–	100	kHz
		from 1 to 10 MHz; 9 steps (logarithmic): n = 0 to 8	–	note 1	–	MHz
		from 10 to 200 MHz	–	–	2	MHz
		from 200 to 1 000 MHz	–	–	20	MHz
V <sub>IL(rms)</sub>	immunity voltage level (RMS value)	from 250 kHz to 1 MHz	5	–	–	V
		from 1 MHz to 5 MHz	10	–	–	V
		from 5 MHz to 1 GHz	15	–	–	V
V <sub>TL(max)</sub>	maximum test voltage level		–	24	–	V
V <sub>START(rms)</sub>	voltage start level (RMS value)		2	4	6	V
V <sub>STEP(rms)</sub>	voltage level step (RMS value)		–	2	–	V
Q <sub>TL</sub>	relative accuracy of test level		–10	–	+10	%
t <sub>dwell</sub>	dwel time		2	–	–	s
<b>RF-voltage characteristic; note 2</b>						
f <sub>M(AM)</sub>	AM modulation frequency	constant peak level	–	1	–	kHz
m <sub>D</sub>	modulation depth	constant peak level	–	0	–	%

**Notes**

1. The typical value is  $1 \times 10^{\frac{n}{9}}$
2. For definition see "ISO/DIS 11452-1", annex B.



Light position controller

TDA3629

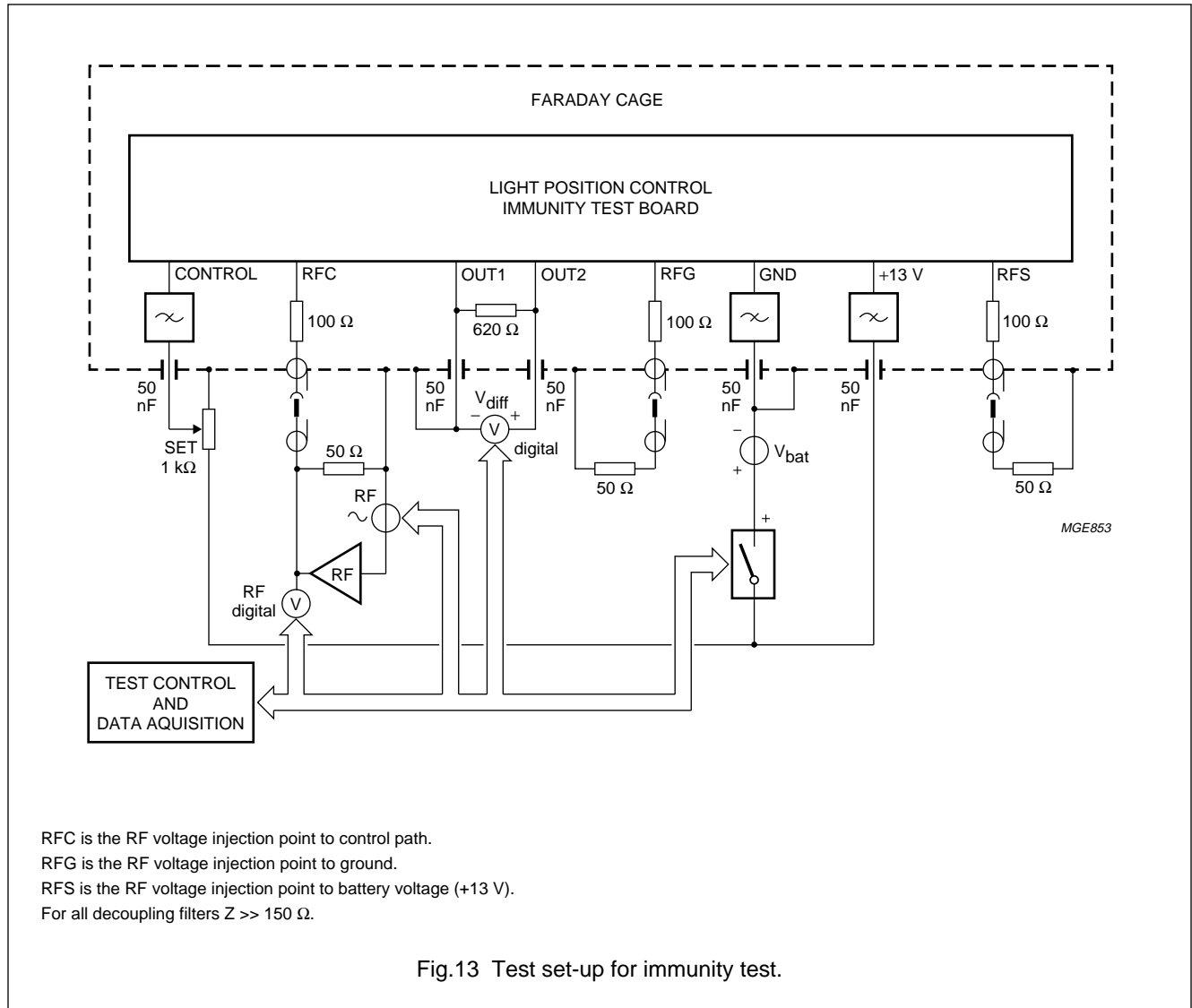

Light position controller

TDA3629

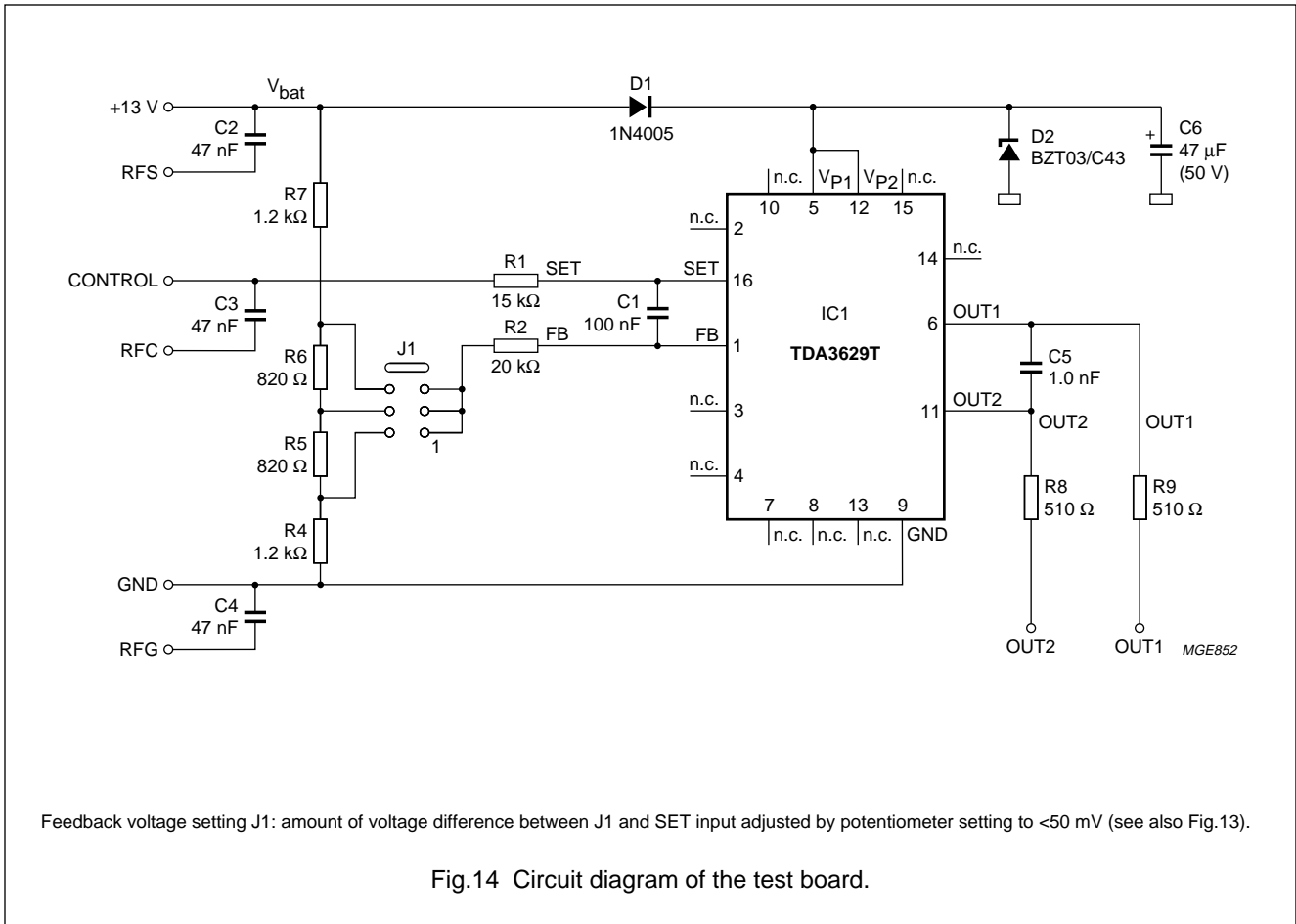

Figs 15 to 17 show the layout of the immunity test board used for the evaluation.

Light position controller

TDA3629

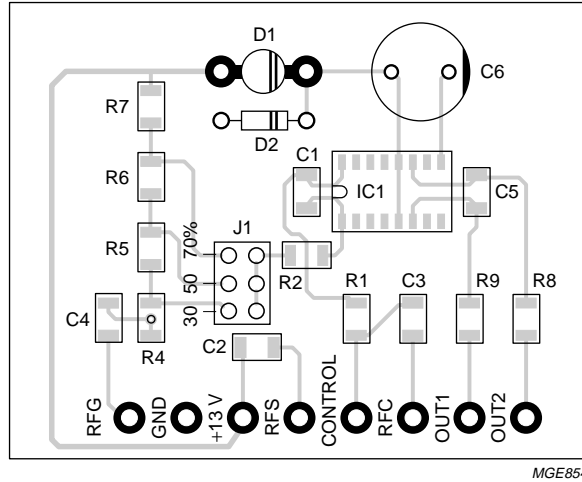

Fig.15 Component placement of the printed-circuit board.

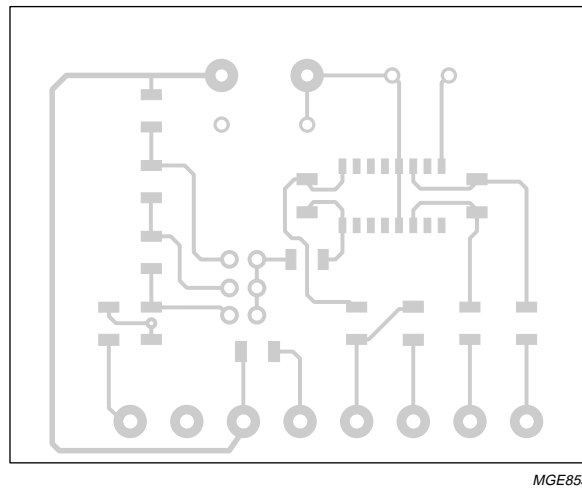

Fig.16 Top view of printed-circuit board.

Light position controller

TDA3629

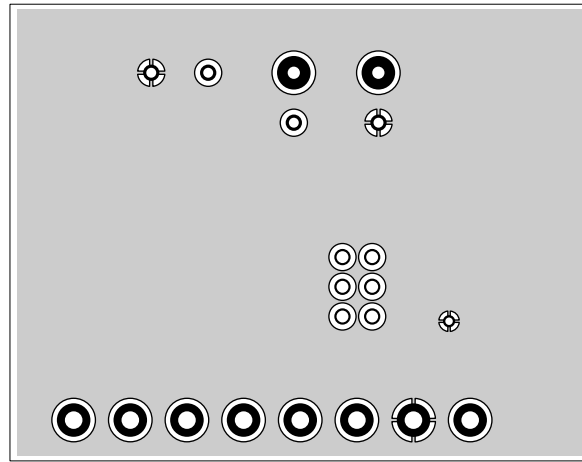
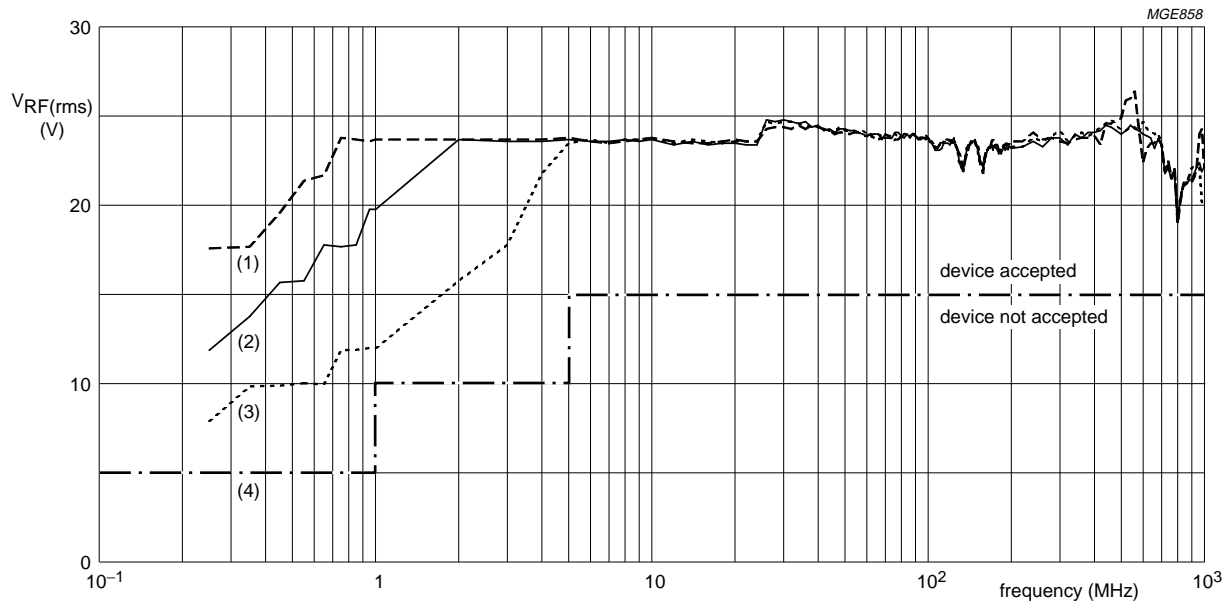

Fig.17 Bottom view of printed-circuit board.

Test results



- (1) Feedback voltage is 30%.
- (2) Feedback voltage is 50%.
- (3) Feedback voltage is 70%.
- (4) Immunity level.

Fig.18 Typical immunity results with respect to setting of jumper 1 (30, 50 and 70%) RF input to RFC.

Light position controller

TDA3629

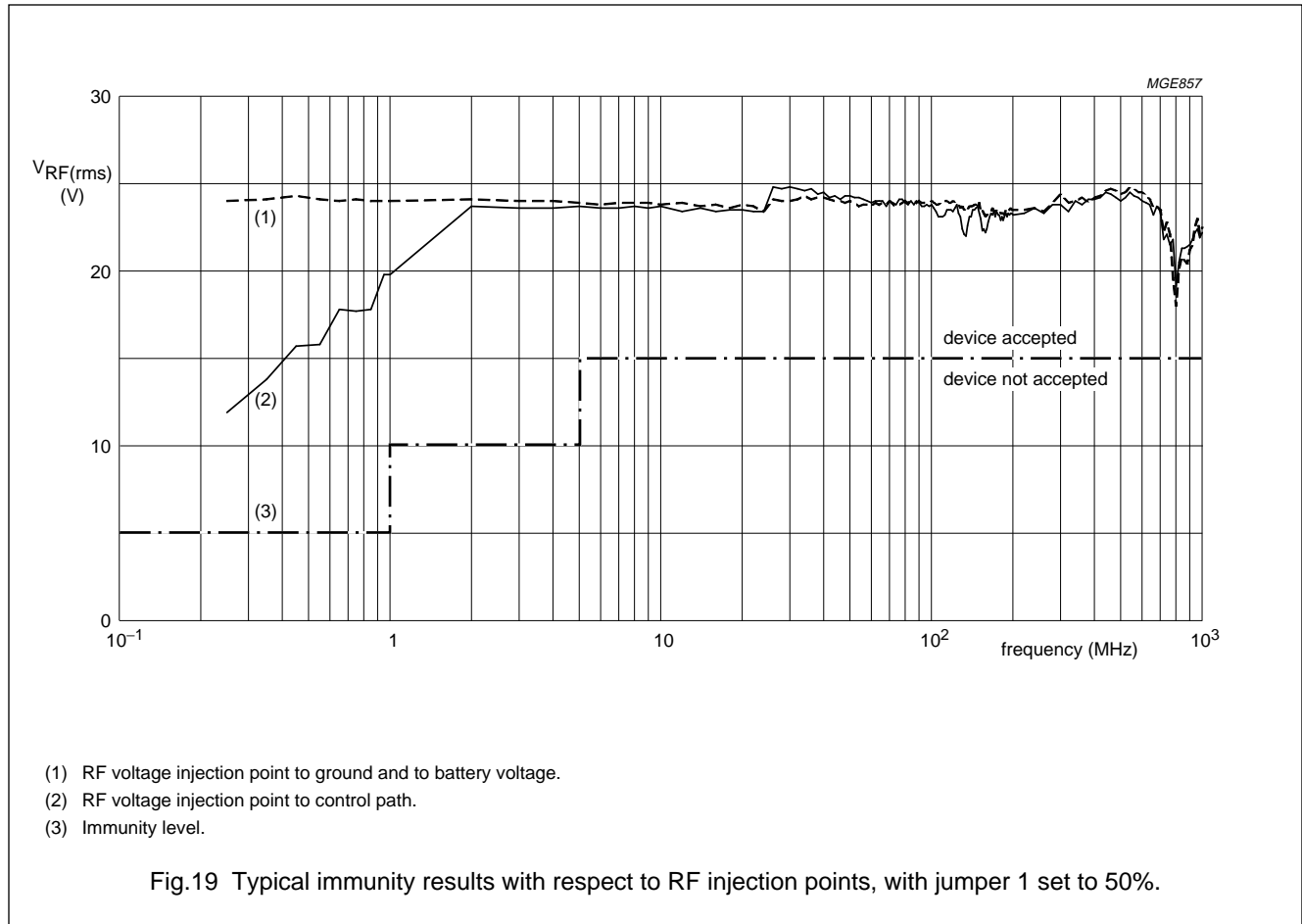

The typical immunity results of the TDA3629T are shown in Fig.18. The RF voltage was injected into the control line (see also Figs 13 and 14). This injection point is the most sensitive one that could be found. This is underlined by the comparison results shown in Fig.19.

Light position controller

TDA3629

PACKAGE OUTLINES

DIP8: plastic dual in-line package; 8 leads (300 mil)

SOT97-1

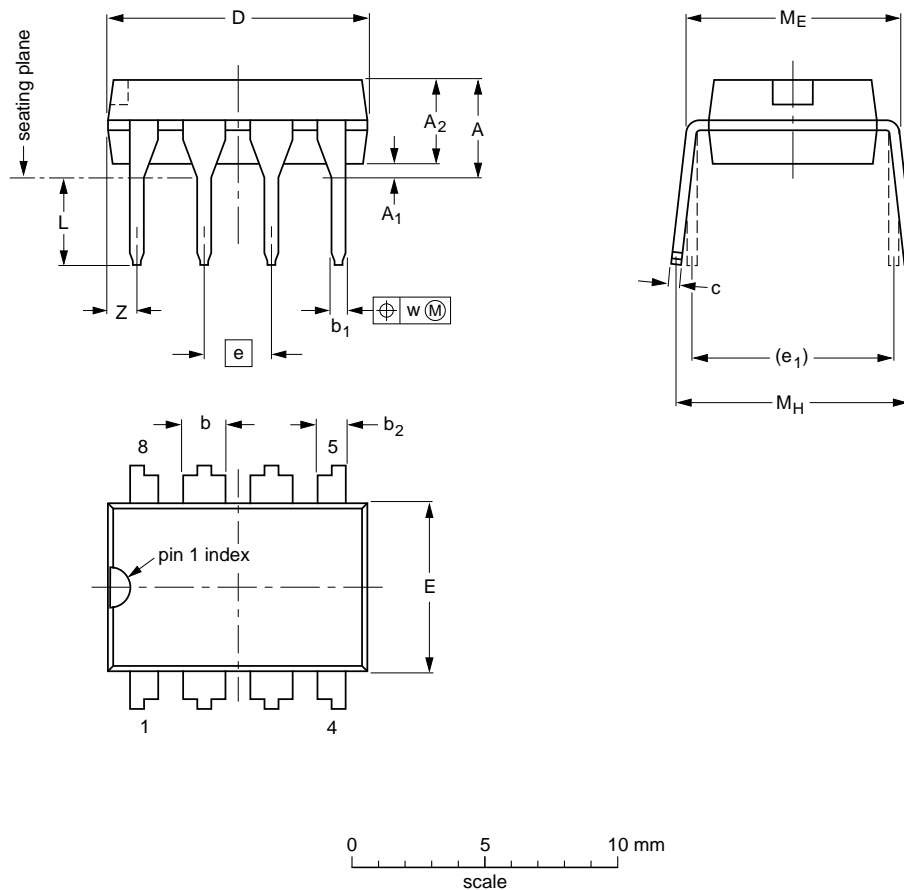

DIMENSIONS (inch dimensions are derived from the original mm dimensions)

UNIT	A max.	A <sub>1</sub> min.	A <sub>2</sub> max.	b	b <sub>1</sub>	b <sub>2</sub>	c	D <sup>(1)</sup>	E <sup>(1)</sup>	e	e <sub>1</sub>	L	M <sub>E</sub>	M <sub>H</sub>	w	Z <sup>(1)</sup> max.
mm	4.2	0.51	3.2	1.73 1.14	0.53 0.38	1.07 0.89	0.36 0.23	9.8 9.2	6.48 6.20	2.54	7.62	3.60 3.05	8.25 7.80	10.0 8.3	0.254	1.15
inches	0.17	0.020	0.13	0.068 0.045	0.021 0.015	0.042 0.035	0.014 0.009	0.39 0.36	0.26 0.24	0.10	0.30	0.14 0.12	0.32 0.31	0.39 0.33	0.01	0.045

Note

1. Plastic or metal protrusions of 0.25 mm maximum per side are not included.

OUTLINE VERSION	REFERENCES				EUROPEAN PROJECTION	ISSUE DATE
	IEC	JEDEC	EIAJ			
SOT97-1	050G01	MO-001AN				92-11-17 95-02-04

Light position controller

TDA3629

SOT16: plastic small outline package; 16 leads; body width 3.9 mm

SOT109-1

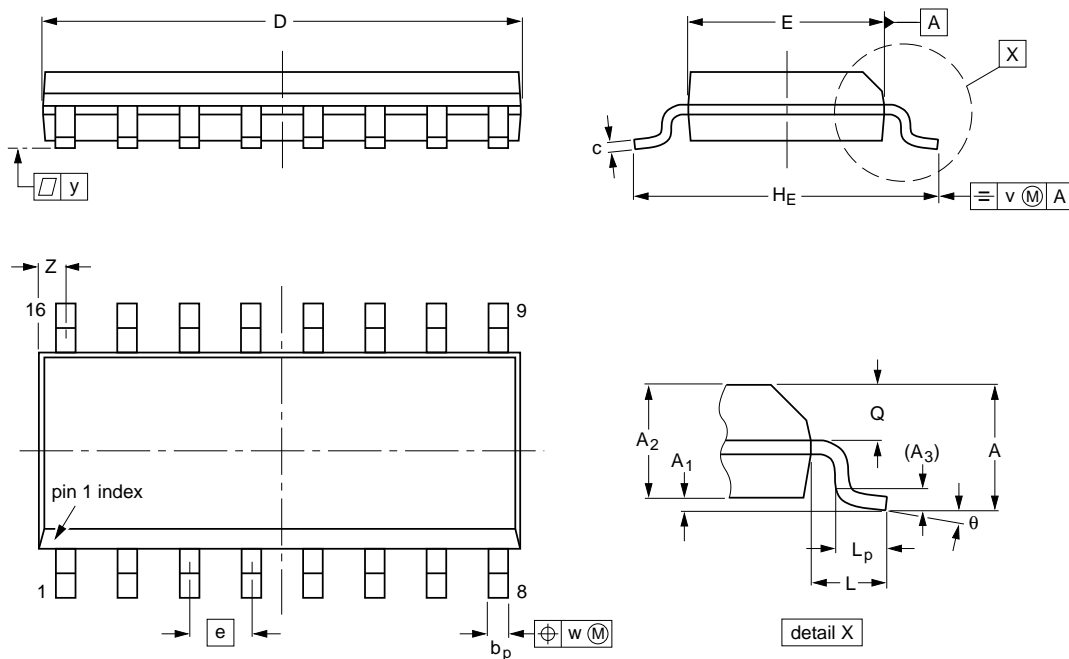

**DIMENSIONS (inch dimensions are derived from the original mm dimensions)**

UNIT	A max.	A <sub>1</sub>	A <sub>2</sub>	A <sub>3</sub>	b <sub>p</sub>	c	D <sup>(1)</sup>	E <sup>(1)</sup>	e	H <sub>E</sub>	L	L <sub>p</sub>	Q	v	w	y	Z <sup>(1)</sup>	θ
mm	1.75	0.25 0.10	1.45 1.25	0.25	0.49 0.36	0.25 0.19	10.0 9.8	4.0 3.8	1.27	6.2 5.8	1.05	1.0 0.4	0.7 0.6	0.25	0.25	0.1	0.7 0.3	8° 0°
inches	0.069	0.0098 0.0039	0.057 0.049	0.01	0.019 0.014	0.0098 0.0075	0.39 0.38	0.16 0.15	0.050	0.24 0.23	0.041	0.039 0.016	0.028 0.020	0.01	0.01	0.004	0.028 0.012	

**Note**

1. Plastic or metal protrusions of 0.15 mm maximum per side are not included.

OUTLINE VERSION	REFERENCES				EUROPEAN PROJECTION	ISSUE DATE
	IEC	JEDEC	EIAJ			
SOT109-1	076E07S	MS-012AC				91-08-13 95-01-23

## Light position controller

TDA3629

### SOLDERING

#### Introduction

There is no soldering method that is ideal for all IC packages. Wave soldering is often preferred when through-hole and surface mounted components are mixed on one printed-circuit board. However, wave soldering is not always suitable for surface mounted ICs, or for printed-circuits with high population densities. In these situations reflow soldering is often used.

This text gives a very brief insight to a complex technology. A more in-depth account of soldering ICs can be found in our *"IC Package Databook"* (order code 9398 652 90011).

#### DIP

##### SOLDERING BY DIPPING OR BY WAVE

The maximum permissible temperature of the solder is 260 °C; solder at this temperature must not be in contact with the joint for more than 5 seconds. The total contact time of successive solder waves must not exceed 5 seconds.

The device may be mounted up to the seating plane, but the temperature of the plastic body must not exceed the specified maximum storage temperature ( $T_{stg\ max}$ ). If the printed-circuit board has been pre-heated, forced cooling may be necessary immediately after soldering to keep the temperature within the permissible limit.

##### REPAIRING SOLDERED JOINTS

Apply a low voltage soldering iron (less than 24 V) to the lead(s) of the package, below the seating plane or not more than 2 mm above it. If the temperature of the soldering iron bit is less than 300 °C it may remain in contact for up to 10 seconds. If the bit temperature is between 300 and 400 °C, contact may be up to 5 seconds.

#### SO

##### REFLOW SOLDERING

Reflow soldering techniques are suitable for all SO packages.

Reflow soldering requires solder paste (a suspension of fine solder particles, flux and binding agent) to be applied to the printed-circuit board by screen printing, stencilling or pressure-syringe dispensing before package placement.

Several techniques exist for reflowing; for example, thermal conduction by heated belt. Dwell times vary between 50 and 300 seconds depending on heating method. Typical reflow temperatures range from 215 to 250 °C.

Preheating is necessary to dry the paste and evaporate the binding agent. Preheating duration: 45 minutes at 45 °C.

##### WAVE SOLDERING

Wave soldering techniques can be used for all SO packages if the following conditions are observed:

- A double-wave (a turbulent wave with high upward pressure followed by a smooth laminar wave) soldering technique should be used.
- The longitudinal axis of the package footprint must be parallel to the solder flow.
- The package footprint must incorporate solder thieves at the downstream end.

During placement and before soldering, the package must be fixed with a droplet of adhesive. The adhesive can be applied by screen printing, pin transfer or syringe dispensing. The package can be soldered after the adhesive is cured.

Maximum permissible solder temperature is 260 °C, and maximum duration of package immersion in solder is 10 seconds, if cooled to less than 150 °C within 6 seconds. Typical dwell time is 4 seconds at 250 °C.

A mildly-activated flux will eliminate the need for removal of corrosive residues in most applications.

##### REPAIRING SOLDERED JOINTS

Fix the component by first soldering two diagonally-opposite end leads. Use only a low voltage soldering iron (less than 24 V) applied to the flat part of the lead. Contact time must be limited to 10 seconds at up to 300 °C. When using a dedicated tool, all other leads can be soldered in one operation within 2 to 5 seconds between 270 and 320 °C.



## Light position controller

TDA3629

**DEFINITIONS**

<b>Data sheet status</b>	
Objective specification	This data sheet contains target or goal specifications for product development.
Preliminary specification	This data sheet contains preliminary data; supplementary data may be published later.
Product specification	This data sheet contains final product specifications.
<b>Limiting values</b>	
Limiting values given are in accordance with the Absolute Maximum Rating System (IEC 134). Stress above one or more of the limiting values may cause permanent damage to the device. These are stress ratings only and operation of the device at these or at any other conditions above those given in the Characteristics sections of the specification is not implied. Exposure to limiting values for extended periods may affect device reliability.	
<b>Application information</b>	
Where application information is given, it is advisory and does not form part of the specification.	

**LIFE SUPPORT APPLICATIONS**

These products are not designed for use in life support appliances, devices, or systems where malfunction of these products can reasonably be expected to result in personal injury. Philips customers using or selling these products for use in such applications do so at their own risk and agree to fully indemnify Philips for any damages resulting from such improper use or sale.

---

Light position controller

TDA3629

---

**NOTES**

---

Light position controller

TDA3629

---

**NOTES**

# Philips Semiconductors – a worldwide company

**Argentina:** see South America

**Australia:** 34 Waterloo Road, NORTH RYDE, NSW 2113,  
Tel. +61 2 9805 4455, Fax. +61 2 9805 4466

**Austria:** Computerstr. 6, A-1101 WIEN, P.O. Box 213,  
Tel. +43 1 60 101, Fax. +43 1 60 101 1210

**Belarus:** Hotel Minsk Business Center, Bld. 3, r. 1211, Volodarski Str. 6,  
220050 MINSK, Tel. +375 172 200 733, Fax. +375 172 200 773

**Belgium:** see The Netherlands

**Brazil:** see South America

**Bulgaria:** Philips Bulgaria Ltd., Energoproject, 15th floor,  
51 James Bourchier Blvd., 1407 SOFIA,  
Tel. +359 2 689 211, Fax. +359 2 689 102

**Canada:** PHILIPS SEMICONDUCTORS/COMPONENTS,  
Tel. +1 800 234 7381

**China/Hong Kong:** 501 Hong Kong Industrial Technology Centre,  
72 Tat Chee Avenue, Kowloon Tong, HONG KONG,  
Tel. +852 2319 7888, Fax. +852 2319 7700

**Colombia:** see South America

**Czech Republic:** see Austria

**Denmark:** Prags Boulevard 80, PB 1919, DK-2300 COPENHAGEN S,  
Tel. +45 32 88 2636, Fax. +45 31 57 1949

**Finland:** Sinikalliontie 3, FIN-02630 ESPOO,  
Tel. +358 615 800, Fax. +358 615 80920

**France:** 4 Rue du Port-aux-Vins, BP317, 92156 SURESNES Cedex,  
Tel. +33 1 40 99 6161, Fax. +33 1 40 99 6427

**Germany:** Hammerbrookstraße 69, D-20097 HAMBURG,  
Tel. +49 40 23 53 60, Fax. +49 40 23 536 300

**Greece:** No. 15, 25th March Street, GR 17778 TAVROS,  
Tel. +30 1 4894 339/911, Fax. +30 1 4814 240

**Hungary:** see Austria

**India:** Philips INDIA Ltd, Shivsagar Estate, A Block, Dr. Annie Besant Rd.  
Worli, MUMBAI 400 018, Tel. +91 22 4938 541, Fax. +91 22 4938 722

**Indonesia:** see Singapore

**Ireland:** Newstead, Clonskeagh, DUBLIN 14,  
Tel. +353 1 7640 000, Fax. +353 1 7640 200

**Israel:** RAPAC Electronics, 7 Kehilat Saloniki St, TEL AVIV 61180,  
Tel. +972 3 645 0444, Fax. +972 3 649 1007

**Italy:** PHILIPS SEMICONDUCTORS, Piazza IV Novembre 3,  
20124 MILANO, Tel. +39 2 6752 2531, Fax. +39 2 6752 2557

**Japan:** Philips Bldg 13-37, Kohnan 2-chome, Minato-ku, TOKYO 108,  
Tel. +81 3 3740 5130, Fax. +81 3 3740 5077

**Korea:** Philips House, 260-199 Itaewon-dong, Yongsan-ku, SEOUL,  
Tel. +82 2 709 1412, Fax. +82 2 709 1415

**Malaysia:** No. 76 Jalan Universiti, 46200 PETALING JAYA, SELANGOR,  
Tel. +60 3 750 5214, Fax. +60 3 757 4880

**Mexico:** 5900 Gateway East, Suite 200, EL PASO, TEXAS 79905,  
Tel. +9-5 800 234 7381

**Middle East:** see Italy

**Netherlands:** Postbus 90050, 5600 PB EINDHOVEN, Bldg. VB,  
Tel. +31 40 27 82785, Fax. +31 40 27 88399

**New Zealand:** 2 Wagener Place, C.P.O. Box 1041, AUCKLAND,  
Tel. +64 9 849 4160, Fax. +64 9 849 7811

**Norway:** Box 1, Manglerud 0612, OSLO,  
Tel. +47 22 74 8000, Fax. +47 22 74 8341

**Philippines:** Philips Semiconductors Philippines Inc.,  
106 Valero St. Salcedo Village, P.O. Box 2108 MCC, MAKATI,  
Metro MANILA, Tel. +63 2 816 6380, Fax. +63 2 817 3474

**Poland:** Ul. Lukiska 10, PL 04-123 WARSZAWA,  
Tel. +48 22 612 2831, Fax. +48 22 612 2327

**Portugal:** see Spain

**Romania:** see Italy

**Russia:** Philips Russia, Ul. Usatcheva 35A, 119048 MOSCOW,  
Tel. +7 095 926 5361, Fax. +7 095 564 8323

**Singapore:** Lorong 1, Toa Payoh, SINGAPORE 1231,  
Tel. +65 350 2538, Fax. +65 251 6500

**Slovakia:** see Austria

**Slovenia:** see Italy

**South Africa:** S.A. PHILIPS Pty Ltd., 195-215 Main Road Martindale,  
2092 JOHANNESBURG, P.O. Box 7430 Johannesburg 2000,  
Tel. +27 11 470 5911, Fax. +27 11 470 5494

**South America:** Rua do Rocio 220, 5th floor, Suite 51,  
04552-903 São Paulo, SÃO PAULO - SP, Brazil,  
Tel. +55 11 821 2333, Fax. +55 11 829 1849

**Spain:** Balmes 22, 08007 BARCELONA,  
Tel. +34 3 301 6312, Fax. +34 3 301 4107

**Sweden:** Kottbygatan 7, Akalla, S-16485 STOCKHOLM,  
Tel. +46 8 632 2000, Fax. +46 8 632 2745

**Switzerland:** Allmendstrasse 140, CH-8027 ZÜRICH,  
Tel. +41 1 488 2686, Fax. +41 1 481 7730

**Taiwan:** PHILIPS TAIWAN Ltd., 23-30F, 66,  
Chung Hsiao West Road, Sec. 1, P.O. Box 22978,  
TAIPEI 100, Tel. +886 2 382 4443, Fax. +886 2 382 4444

**Thailand:** PHILIPS ELECTRONICS (THAILAND) Ltd.,  
209/2 Sanpavuth-Bangna Road Prakanong, BANGKOK 10260,  
Tel. +66 2 745 4090, Fax. +66 2 398 0793

**Turkey:** Talatpasa Cad. No. 5, 80640 GÜLTEPE/ISTANBUL,  
Tel. +90 212 279 2770, Fax. +90 212 282 6707

**Ukraine:** PHILIPS UKRAINE, 4 Patrice Lumumba str., Building B, Floor 7,  
252042 KIEV, Tel. +380 44 264 2776, Fax. +380 44 268 0461

**United Kingdom:** Philips Semiconductors Ltd., 276 Bath Road, Hayes,  
MIDDLESEX UB3 5BX, Tel. +44 181 730 5000, Fax. +44 181 754 8421

**United States:** 811 East Arques Avenue, SUNNYVALE, CA 94088-3409,  
Tel. +1 800 234 7381

**Uruguay:** see South America

**Vietnam:** see Singapore

**Yugoslavia:** PHILIPS, Trg N. Pasica 5/v, 11000 BEOGRAD,  
Tel. +381 11 825 344, Fax. +381 11 635 777

**For all other countries apply to:** Philips Semiconductors, Marketing & Sales Communications,  
Building BE-p, P.O. Box 218, 5600 MD EINDHOVEN, The Netherlands, Fax. +31 40 27 24825

**Internet:** <http://www.semiconductors.philips.com>

© Philips Electronics N.V. 1996

SCA51

All rights are reserved. Reproduction in whole or in part is prohibited without the prior written consent of the copyright owner.

The information presented in this document does not form part of any quotation or contract, is believed to be accurate and reliable and may be changed without notice. No liability will be accepted by the publisher for any consequence of its use. Publication thereof does not convey nor imply any license under patent- or other industrial or intellectual property rights.

Printed in The Netherlands

617021/1200/01/pp28

Date of release: 1996 Sep 04

Document order number: 9397 750 01139

*Let's make things better.*

**Philips  
Semiconductors**



**PHILIPS**

This datasheet has been download from:

[www.datasheetcatalog.com](http://www.datasheetcatalog.com)

Datasheets for electronics components.