

- APS sensor pressure
- AQS aquastop switch
- CUC control unit
- CUIO control unit, user interface (B., E., G.)
- DP drain pump
- DSS door safety switch
- UIS54 GIM switch selector interface
- UIB4 ---> GIM
- HE heating element
- HSG heating element (steam generator)
- IF interference filter
- M motor drive
- MEB expansion board
- RE relay
- SET sensor, temperature
- SSG sensor, steam generator
- SM switch, mains
- TL temp. limiter
- TH thermostat
- V valve, double
- VW valve, main wash
- VPW valve, prewash
- VSF valve, steam fill
- X tub
- XX cable, channel

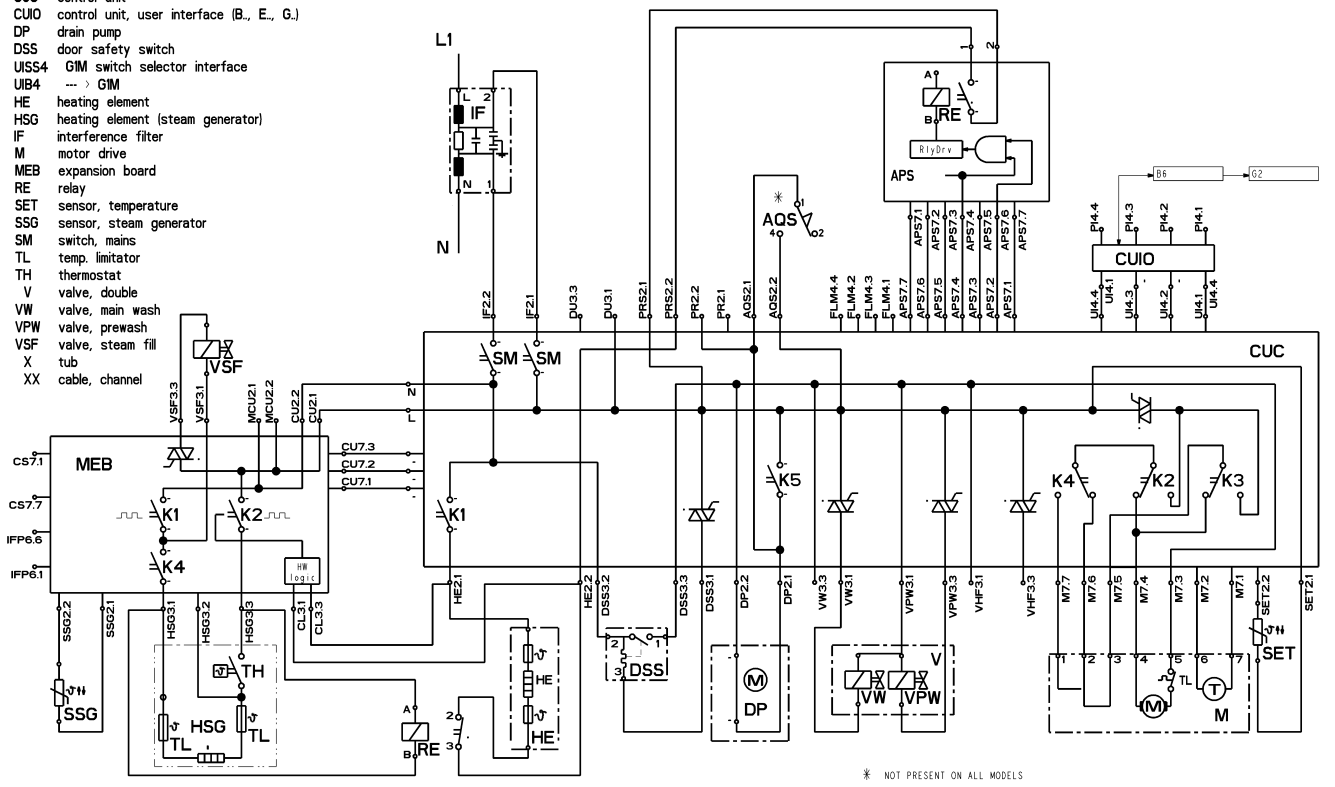

\* NOT PRESENT ON ALL MODELS