

Title		
ARC START CIRCUIT		
Size	Number	Revision
Letter		
Date	5-Mar-2005	Sheet of
File:	C:\Projects\Tig Welder\Tig_Welder.ddb	Drawn By:

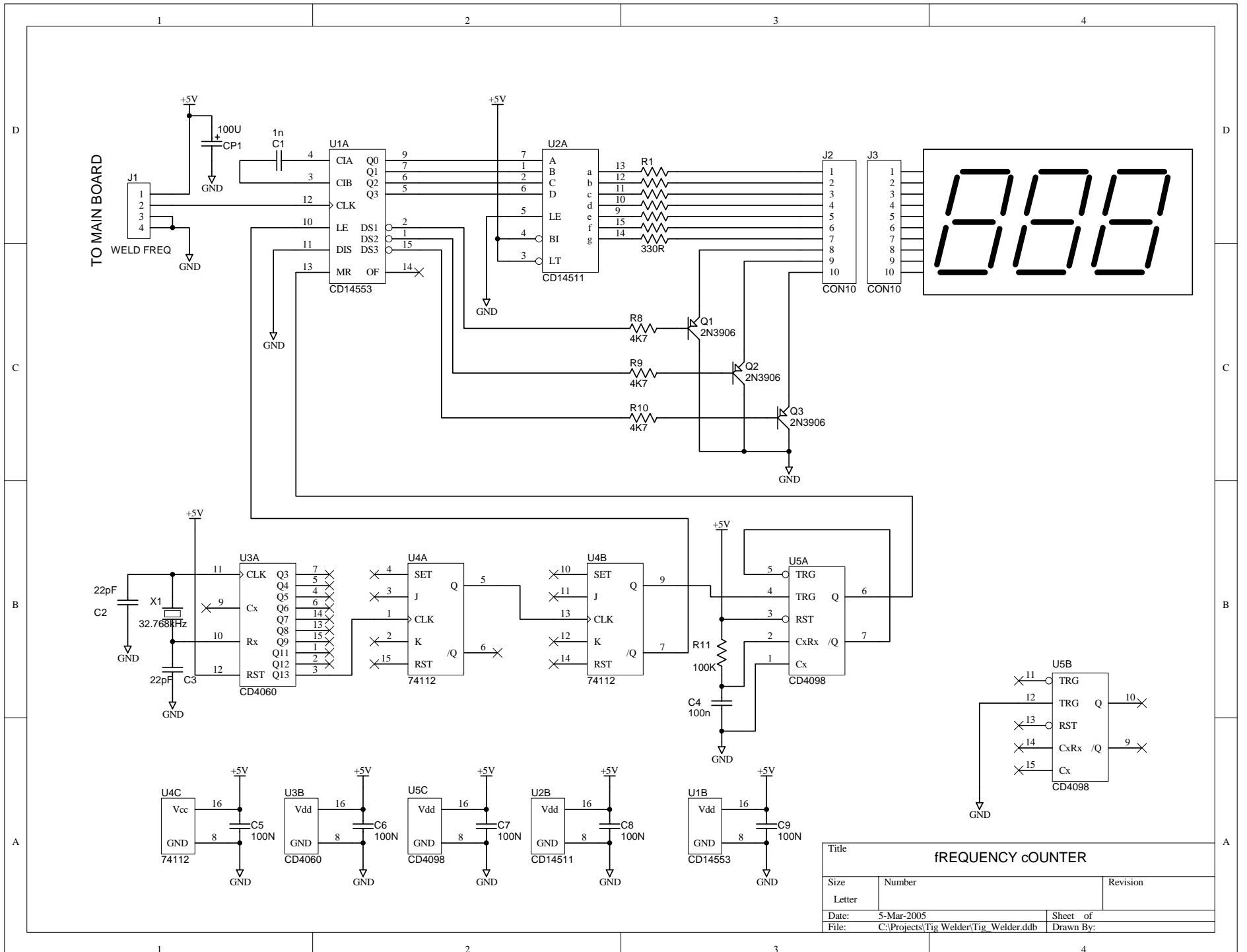

Title			fFREQUENCY cOUNTER		
Size	Number			Revision	
Letter					
Date:	5-Mar-2005			Sheet of	
File:	C:\Projects\Tig Welder\Tig_Welder.ddb			Drawn By:	

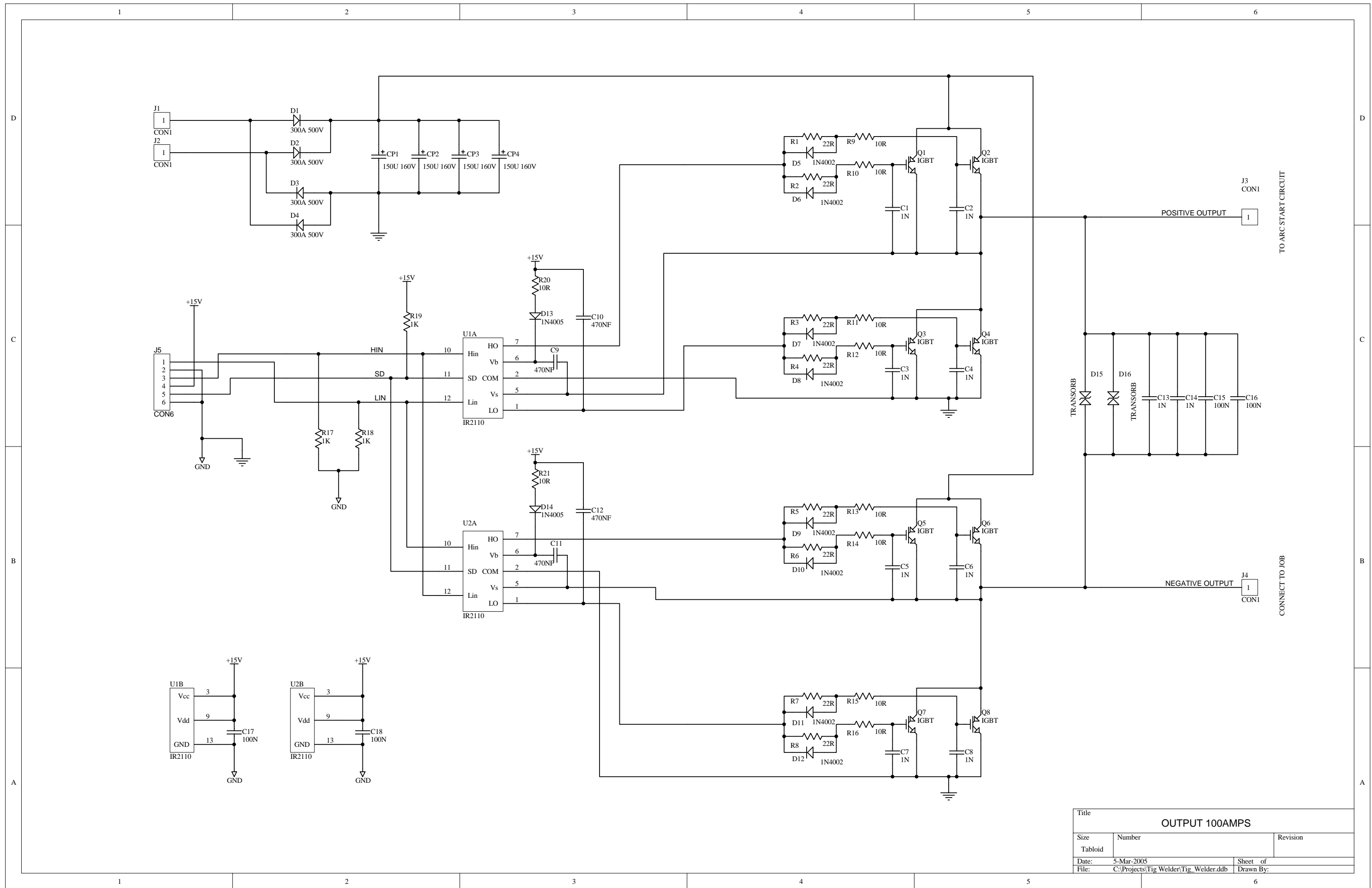

Title		
OUTPUT 100AMPS		
Size	Number	Revision
Tabloid		
Date:	5-Mar-2005	Sheet of
File:	C:\Projects\Tig Welder\Tig_Welder.ddb	Drawn By:

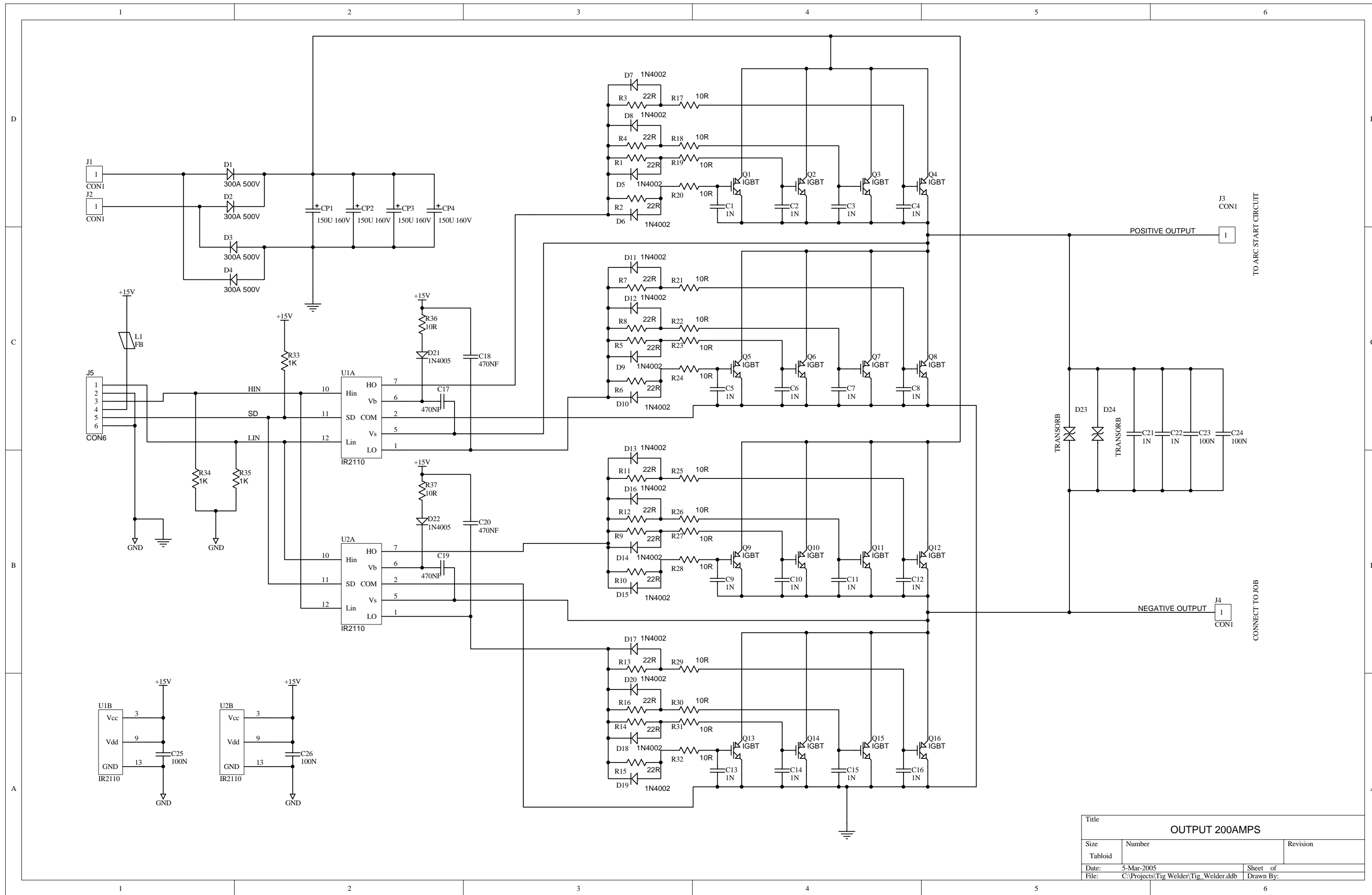

Title		
OUTPUT 200AMPS		
Size	Number	Revision
Tabloid		
Date:	5-Mar-2005	Sheet of
File:	C:\Projects\Tig Welder\Tig_Welder.ddb	Drawn By:

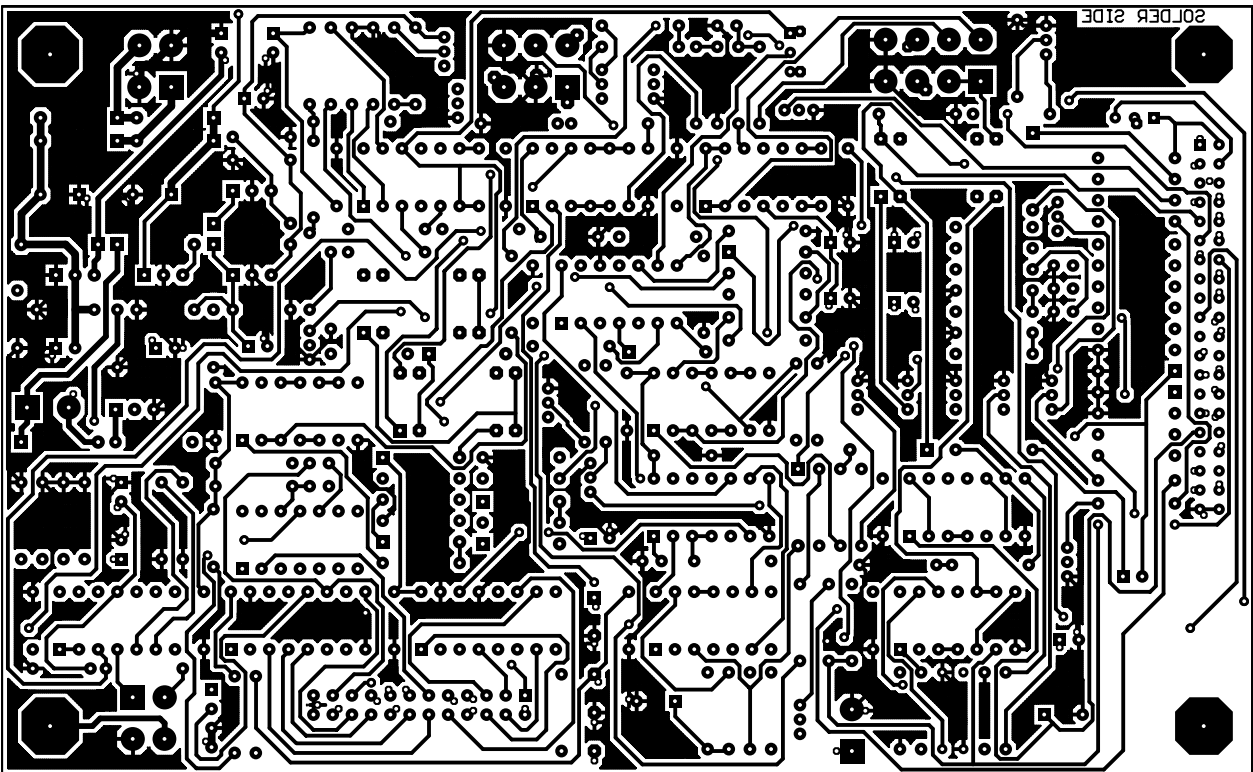

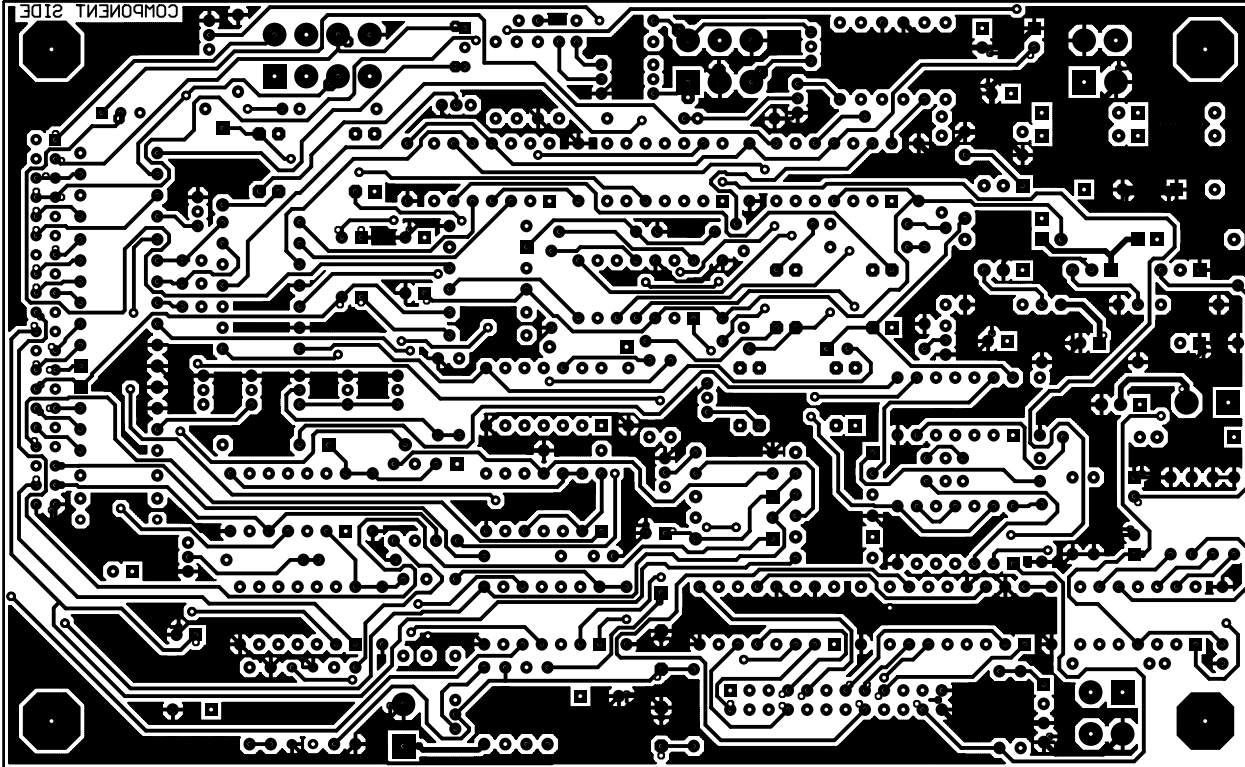

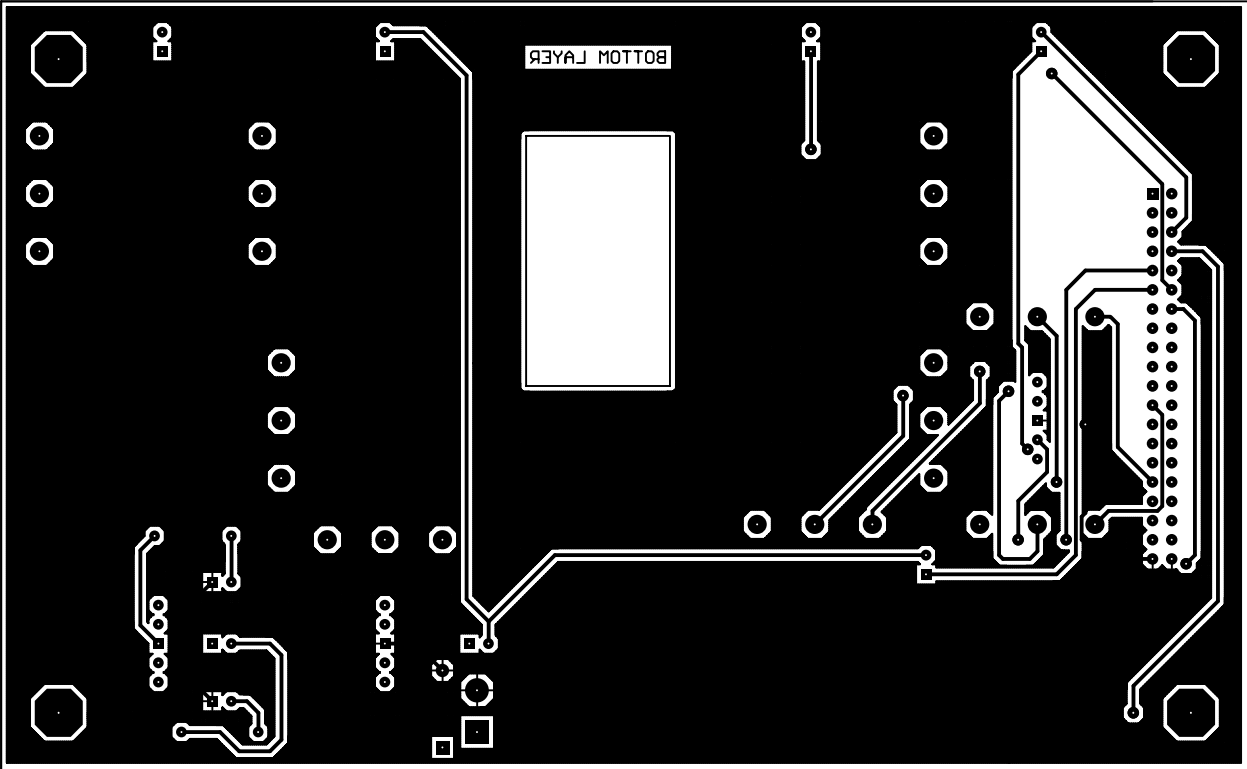

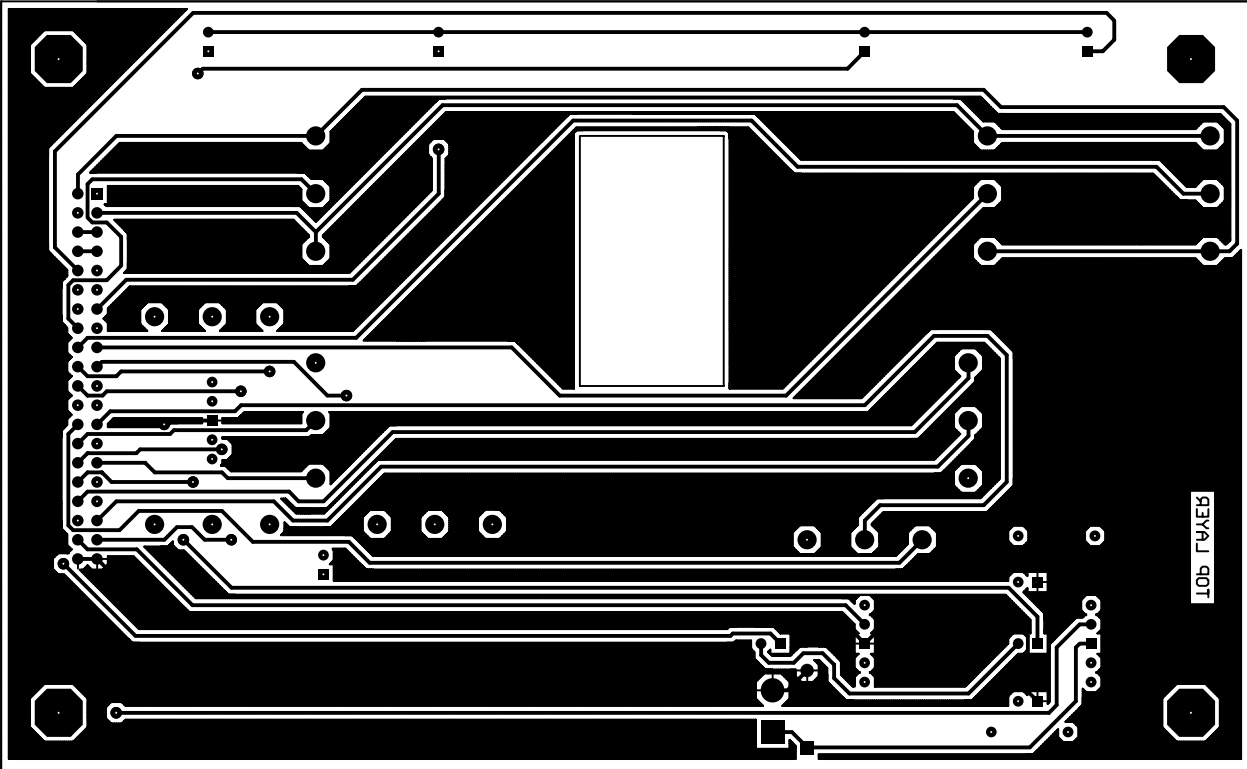

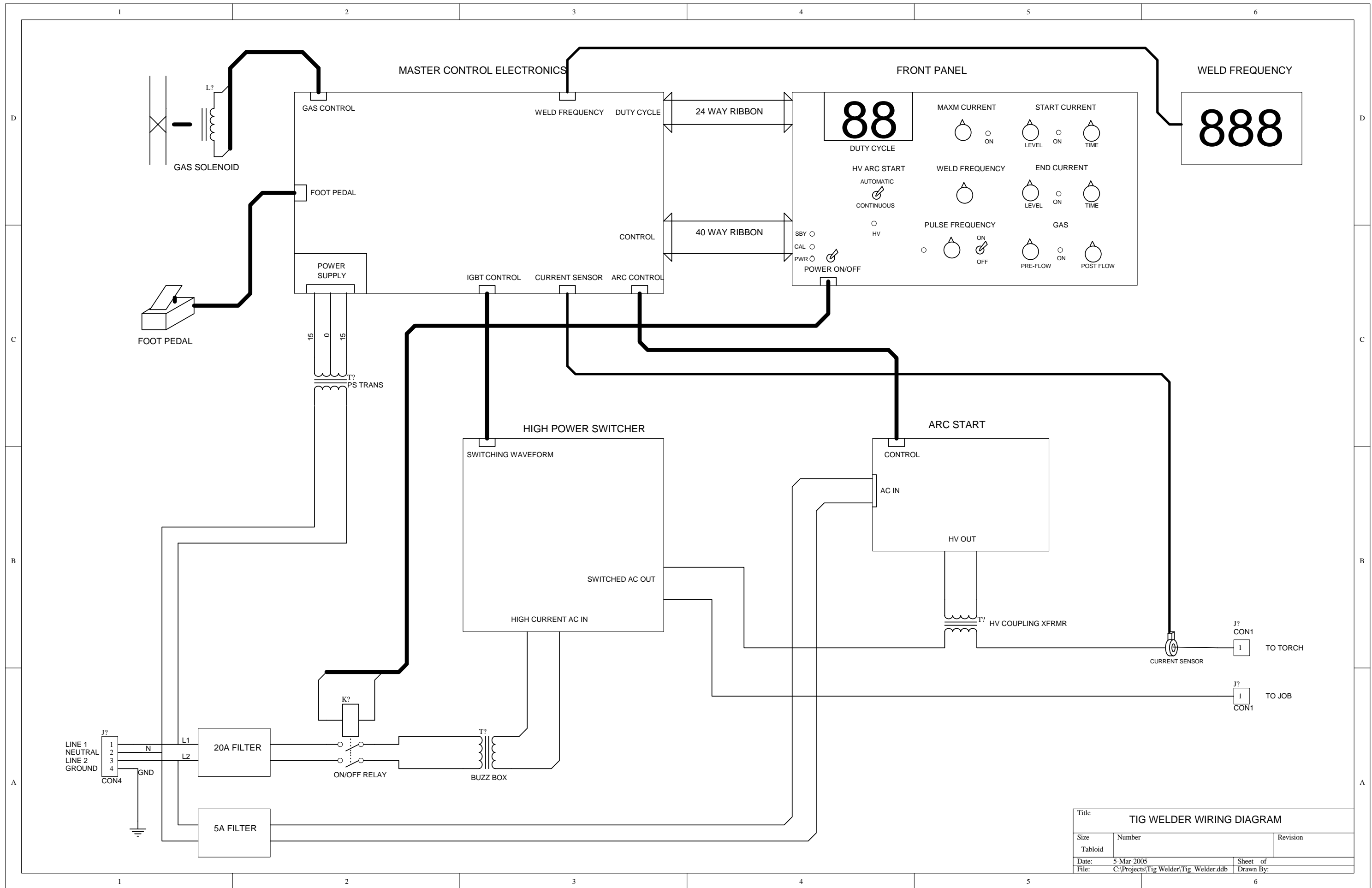

Title		
TIG WELDER WIRING DIAGRAM		
Size	Number	Revision
Tabloid		
Date:	5-Mar-2005	Sheet of
File:	C:\Projects\Tig Welder\Tig_Welder.ddb	Drawn By:

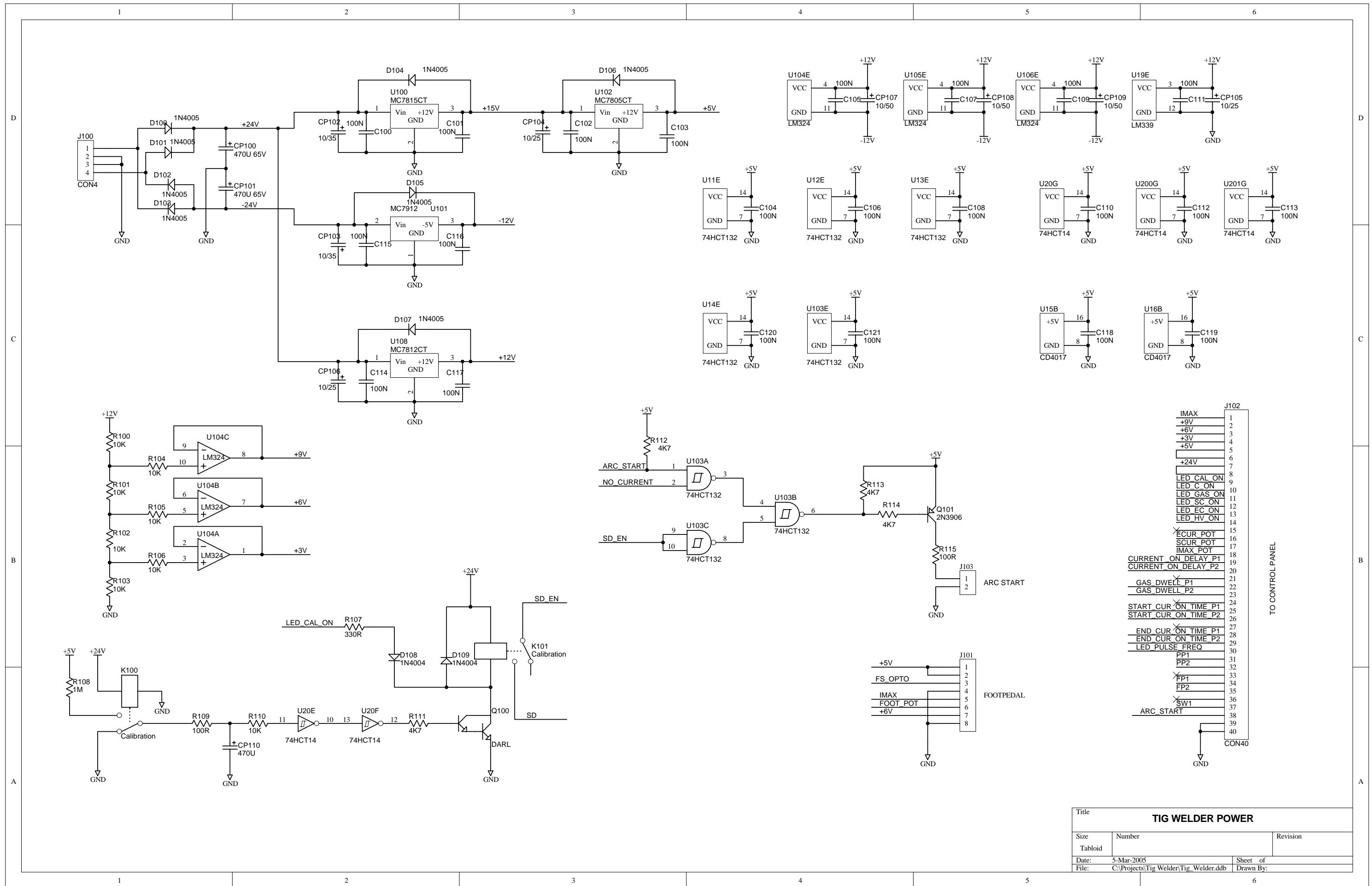

Title		
TIG WELDER POWER		
Size	Number	Revision
Tabloid		
Date:	5-Mar-2005	Sheet of
File:	C:\Projects\Tig Welder\Tig_Welder.ddb	Drawn By:

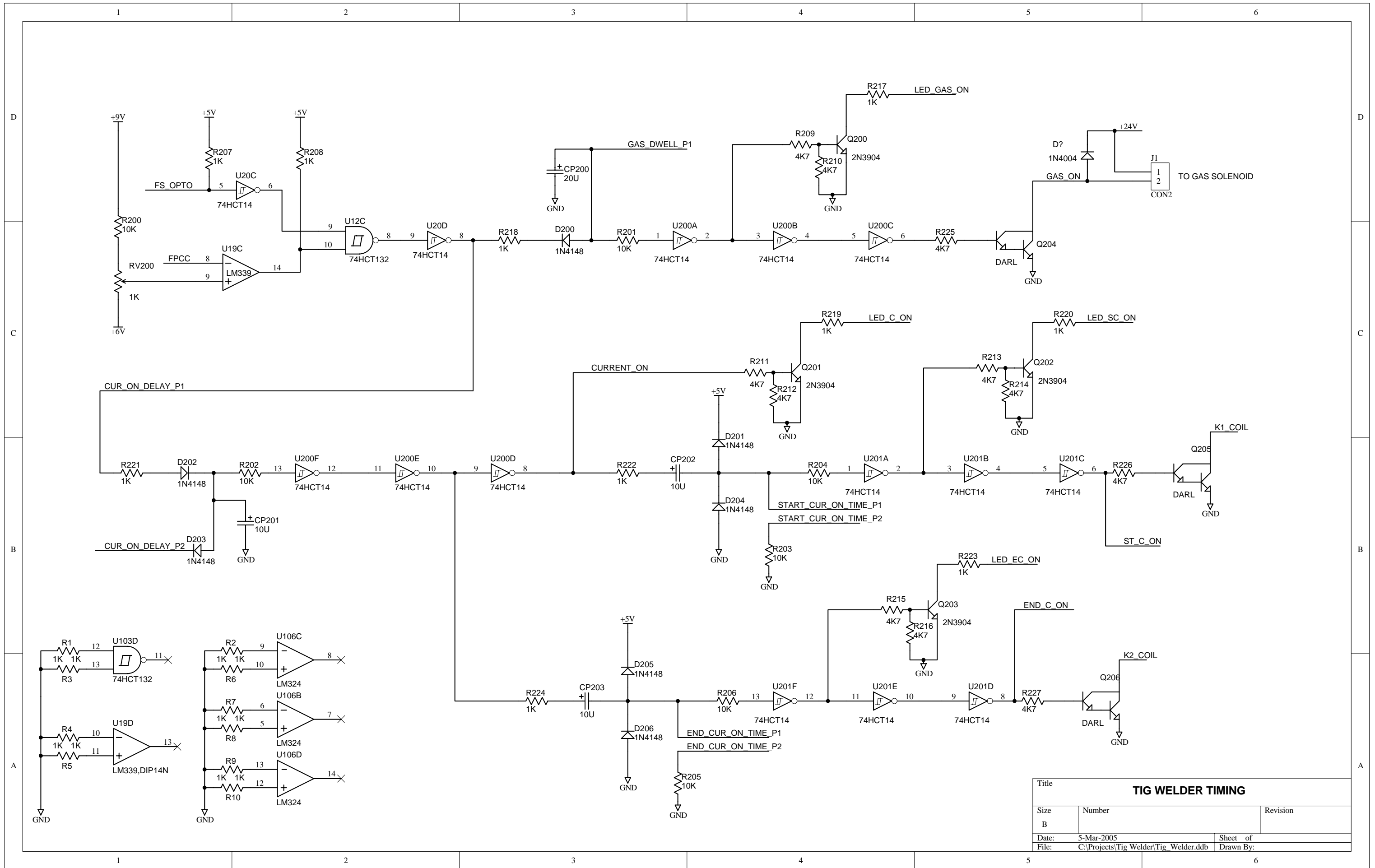

Title		
TIG WELDER TIMING		
Size	Number	Revision
B		
Date:	5-Mar-2005	Sheet of
File:	C:\Projects\Tig Welder\Tig_Welder.ddb	Drawn By:

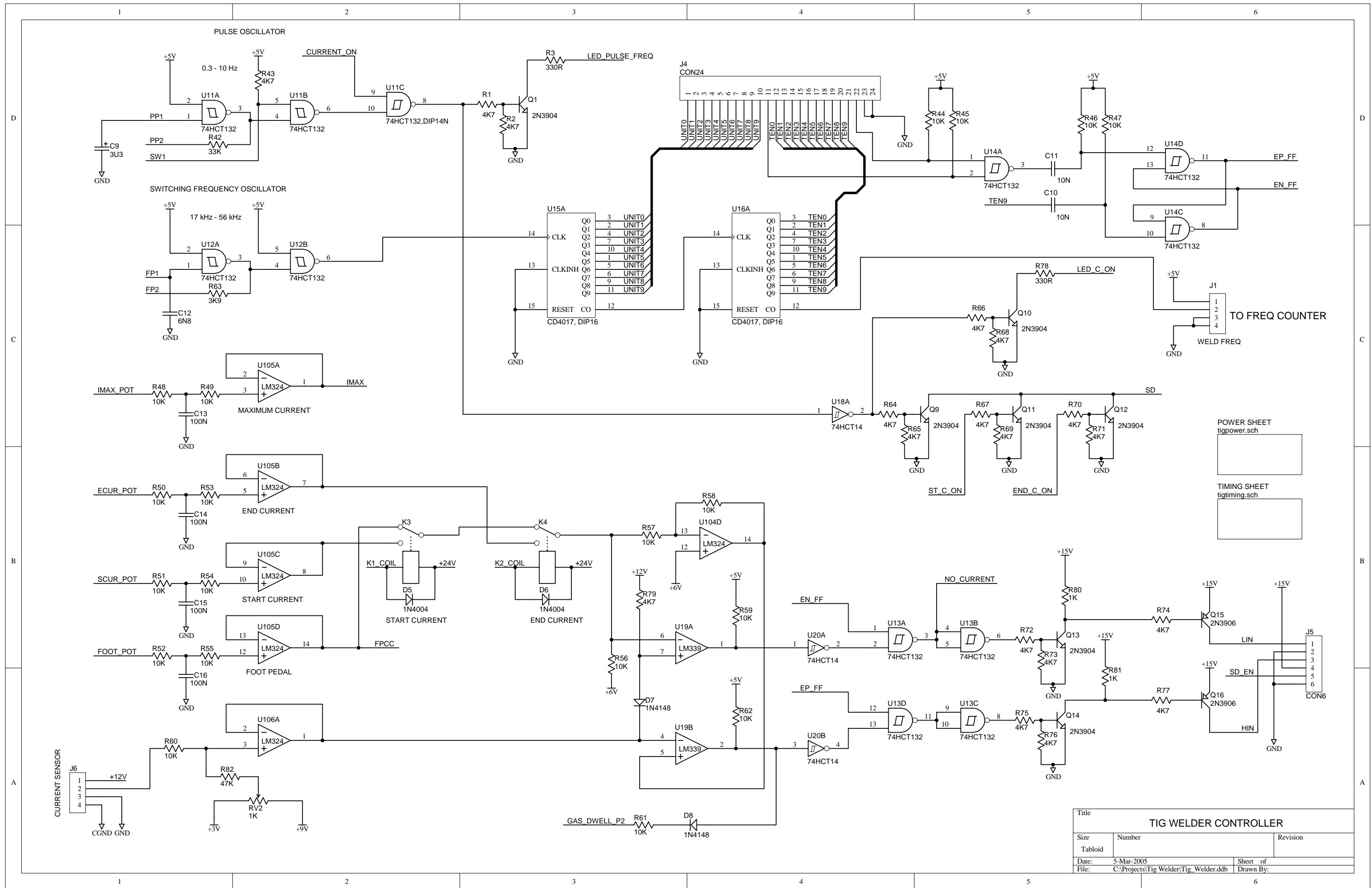

Title		
TIG WELDER CONTROLLER		
Size	Number	Revision
Tabloid		
Date:	5-Mar-2005	Sheet of
File:	C:\Projects\Tig Welder\Tig_Welder.ddb	Drawn By: