

NCP1212

Product Preview

Compact Current Mode PWM Controller

NCP1212 is a high performance current mode controller that is specifically designed for off-line and dc-to-dc converter applications. It requires very few external components and offers designer additional protection for increased system reliability. The device also features a programmable skipping mode for a high efficiency stand-by management. With 50%/80% selectable maximum turn on duty as well as programmable switching frequency, the device is suitable for forward or flyback topology.

Features

- Current Mode Operation
- Inherent Feed Forward Compensation
- Latching PWM for Cycle-By-Cycle Current Limiting
- High Current Totem Pole Output
- Undervoltage Lockout with Hysteresis
- Low Startup Current (100 μ A Typ.)
- Secondary Sensing
- Soft-Start Feature
- 50%/80% Maximum Duty Cycle Selection
- Overvoltage Protection Against Open Loop
- Brownout Detection
- Protection Against Output Overload Irrespective of Auxiliary Voltage Level
- Programmable Skip Mode Low Power Operation

Typical Applications

- ATX PC Power Supply
- AC Adaptor
- CRT Monitor
- All Flyback and Forward SMPS Systems



ON Semiconductor®

<http://onsemi.com>

MARKING DIAGRAMS

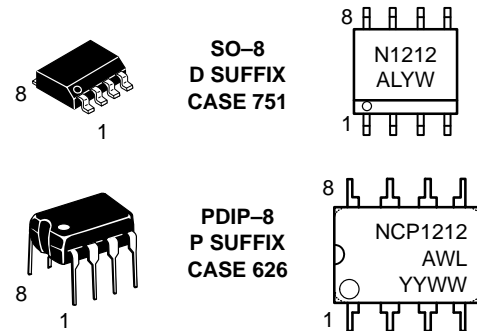

A = Assembly Location
 WL, L = Wafer Lot
 YY, Y = Year
 WW, W = Work Week

PIN CONNECTIONS

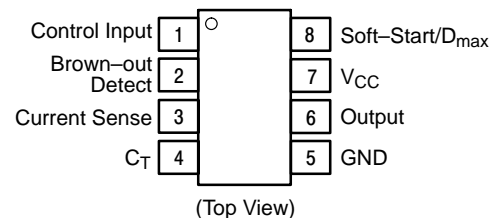

ORDERING INFORMATION

Device	Package	Shipping
NCP1212D	SO-8	98 Units/Rail
NCP1212DR2	SO-8	2500 Tape & Reel
NCP1212P	PDIP-8	50 Units/Rail

This document contains information on a product under development. ON Semiconductor reserves the right to change or discontinue this product without notice.

NCP1212

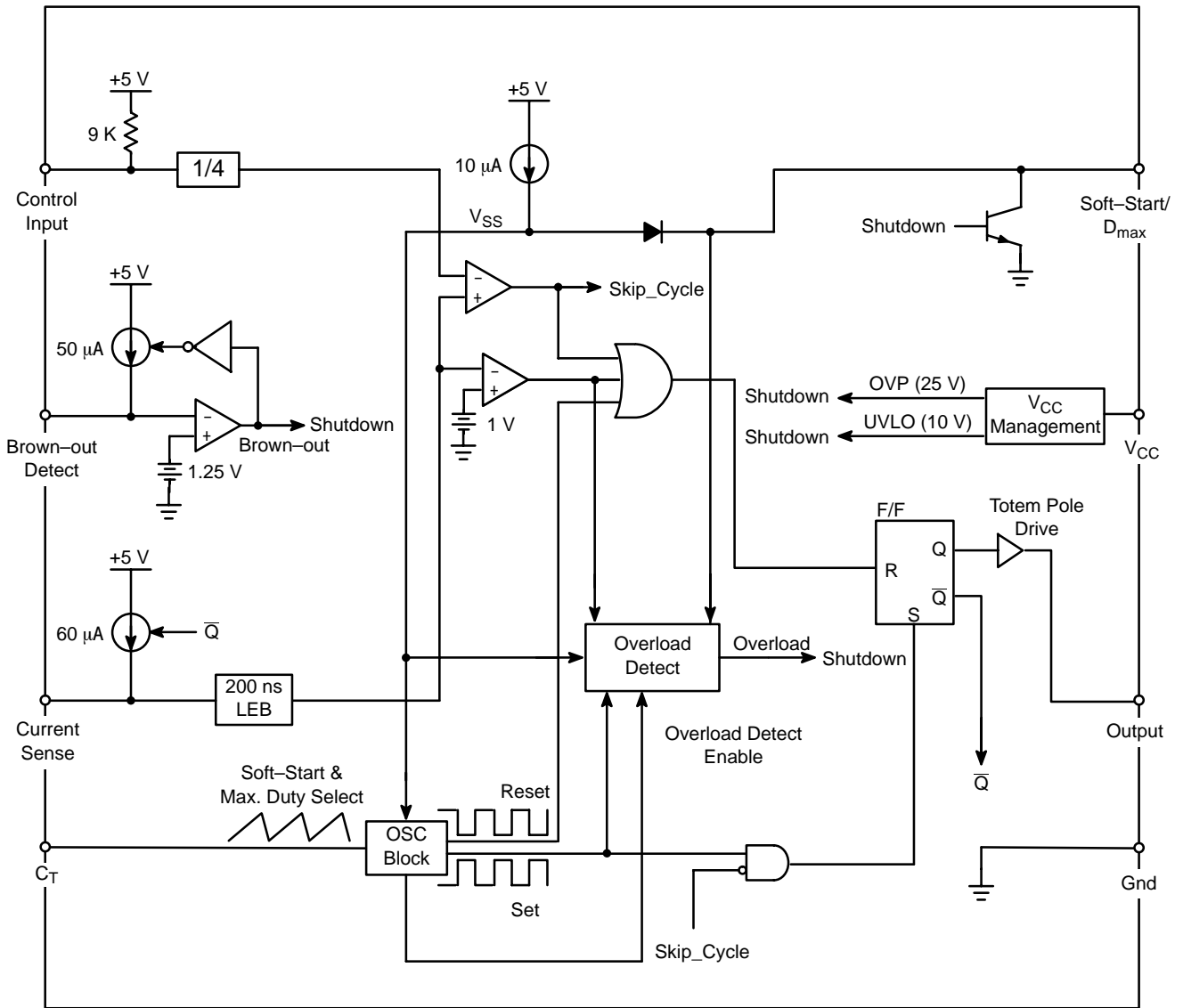

Figure 1. Representative Block Diagram

NCP1212

PIN FUNCTION DESCRIPTION

Pin No.	Function	Description
1	Control Input	This is the secondary voltage feedback input. Connect the opto-coupler collector to this pin.
2	Brown-out Detect	This is the inverting input of the brown-out detect comparator. The brown-out detect comparator has an input threshold voltage of 1.25 V. Voltage of the bulk capacitor is sensed by this pin through a resistor divider. 50 μ A flows out of this pin to provide hysteresis effect if the brown-out detect comparator output is at low level.
3	Current Sense	During Output on-time, this pin receives a voltage proportional to power switch current. This information is utilized to terminate output switch conduction by PWM action or over current limitation. During Output off-time, a 60 μ A internal current source is activated so that placing an external resistor between Current Sense pin and the current sensing resistor, the cycle skipping mode threshold can be programmed.
4	C _T	Oscillator frequency is programmed by connecting a capacitor from C _T pin to ground. Operation up to 150 kHz is possible.
5	Ground	Ground of the IC.
6	Output	The current and slew rate capability of this pin are suitable to drive a Power MOSFET.
7	V _{CC}	This pin is the positive supply of the IC. The driver output gets disabled when the voltage becomes higher than 25 V and the operating range is between 10 V and 25 V. The startup voltage is set at 15 V.
8	Soft-Start/D _{max}	This is a multi-function pin. Soft-start effect is provided during startup with a capacitor connected to this pin. After soft-start period elapsed, the capacitor is used for timing control to determine output overload. If only a capacitor is connected to this pin, its final voltage is 5.0 V and maximum turn-on duty cycle D _{max} is set at 80%. Connect a resistor in parallel with the capacitor can alter the final voltage of this pin, 50% D _{max} is selected if this pin stays at 2.1 V to 2.8 V after soft-start period.

MAXIMUM RATINGS

Rating	Symbol	Value	Unit
Supply Voltage	V _{CC}	27	V
Power Dissipation and Thermal Characteristics for DIP8 Maximum Power Dissipation at T _A = 105°C Thermal Resistance, Junction-to-Air	PD R _{θjA}	400 100	mW °C/W
Power Dissipation and Thermal Characteristics for SO8 Maximum Power Dissipation at T _A = 105°C Thermal Resistance, Junction-to-Air	PD R _{θjA}	240 178	mW °C/W
Output Current, Source or Sink	I _O	1.0	A
Operating Junction Temperature	T _j	150	°C
Operating Ambient Temperature	T _A	-25 to +105	°C

NCP1212

ELECTRICAL CHARACTERISTICS ($V_{CC} = 16\text{ V}$, $d_{\max} = 50\%$, $T_A = T_{\text{low}}$ to T_{high} , unless otherwise noted.)

Characteristic	Symbol	Min	Typ	Max	Unit
----------------	--------	-----	-----	-----	------

OSCILLATION SECTION

Frequency $T_J = 25^\circ\text{C}$ ($d_{\max} = 50\%$, $C_T = 1.0\text{ nF}$) $T_J = 25^\circ\text{C}$ ($d_{\max} = 80\%$, $C_T = 1.0\text{ nF}$) $T_A = T_{\text{low}}$ to T_{high} ($d_{\max} = 50\%$, $C_T = 1.0\text{ nF}$) $T_A = T_{\text{low}}$ to T_{high} ($d_{\max} = 80\%$, $C_T = 1.0\text{ nF}$)	f_{osc}	–	101	–	kHz
		–	95	–	
		95	–	107	
		89	–	101	
Frequency Change with Voltage ($V_{CC} = 13\text{ V}$ to 25 V , $T_J = 25^\circ\text{C}$)	Δf_{osc}	–	0.2	1.0	%
Frequency Change with Temperature	Δf_{osc}	–	5.0	–	%

CURRENT SENSE SECTION

Maximum Current Sense Input Threshold	V_{th}	0.9	1.0	1.1	V
Skipping Mode Threshold Current Source	I_{cs}	48	60	72	μA
Propagation Delay (Current Sense to Gate after LEB Blanking)	T_{PLH}	–	200	250	ns
Leading Edge Blanking Time	T_{LEB}	–	200	–	ns

SOFT-START

Soft-Start Charge Current	I_{ss}	7.0	10	13	μA
Overload Timing Discharge Current	I_{sd}	20	30	–	μA
50% Duty Cycle Selection Input Voltage	V_{s1}	2.1	–	2.8	V
80% Duty Cycle Selection Input Voltage	V_{s2}	3.0	–	–	V

OUTPUT SECTION

Output Resistors $V_{CC} = 15\text{ V}$, $V_{\text{gate}} = 1.0\text{ V}$ $V_{CC} = 15\text{ V}$, $V_{\text{gate}} = V_{CC} - 1.0\text{ V}$	R_{OL} R_{OH}	–	10	–	Ω
		–	20	–	
Output Voltage (from 1.0 V to 11 V) Rise Time ($C_L = 1.0\text{ nF}$, $T_J = 25^\circ\text{C}$)	t_r	–	25	50	ns
Output Voltage (from 11 V to 1.0 V) Fall Time ($C_L = 1.0\text{ nF}$, $T_J = 25^\circ\text{C}$)	t_f	–	50	80	ns

UNDERVOLTAGE LOCKOUT SECTION

Startup Threshold	V_{th}	13.5	15	16.5	V
Overvoltage Threshold	V_{ovth}	22.5	25	27.5	V
Undervoltage Lockout Threshold	V_{UVLO}	8.5	10	11.5	V
Brownout Detection Voltage	V_{BDV}	1.18	1.25	1.31	V
Brownout Hysteresis Current	–	45	50	55	μA

PWM SECTION

Selectable Max. Duty Cycle $2.1\text{ V} < V_{\text{ss}} < 2.8\text{ V}$ $3.0\text{ V} < V_{\text{ss}}$	D_{max1} D_{max2}	–	45	50	%
		–	–	80	

TOTAL DEVICE

Power Supply Current Startup ($V_{CC} = 12\text{ V}$) Operating Shutdown ($V_{CC} = 15\text{ V}$)	I_{cc}	–	0.1	0.2	mA
		–	7.0	10	
		–	3.0	–	
		–	–	–	

NCP1212

Oscillator Section

The oscillator frequency is programmed by the capacitor connected at C_T pin. The capacitor is charged by a constant current source to 3.8 V and 2.6 V for 80% and 50% maximum duty cycle respectively. Once the selected voltage is reached, C_T is discharged by another constant current source to 1.0 V. Desirable switching frequency can be selected by choosing proper value of capacitance. C_T waveform is shown in Figure 2.

PWM Latch Section

NCP1212 works in current mode. The power switch current is converted to a positive voltage by inserting a sensing resistor R_{sense} between the power switch source and the ground. The power switch peak current is cycle-by-cycle compared with the level shifted control input level as shown in Figure 3. The PWM latch is

initialized by the oscillator SET signal and is reset by the current sense comparator when the current exceeds the value dictated by the control input. Then one single pulse appears at the circuit output during each oscillator cycle.

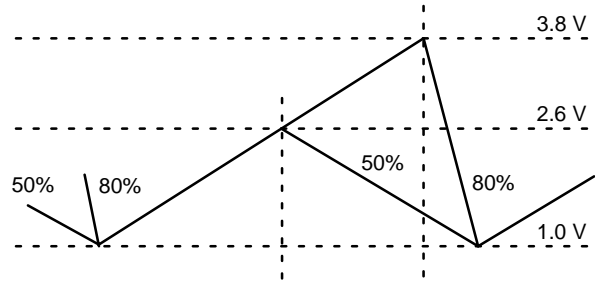

Figure 2.

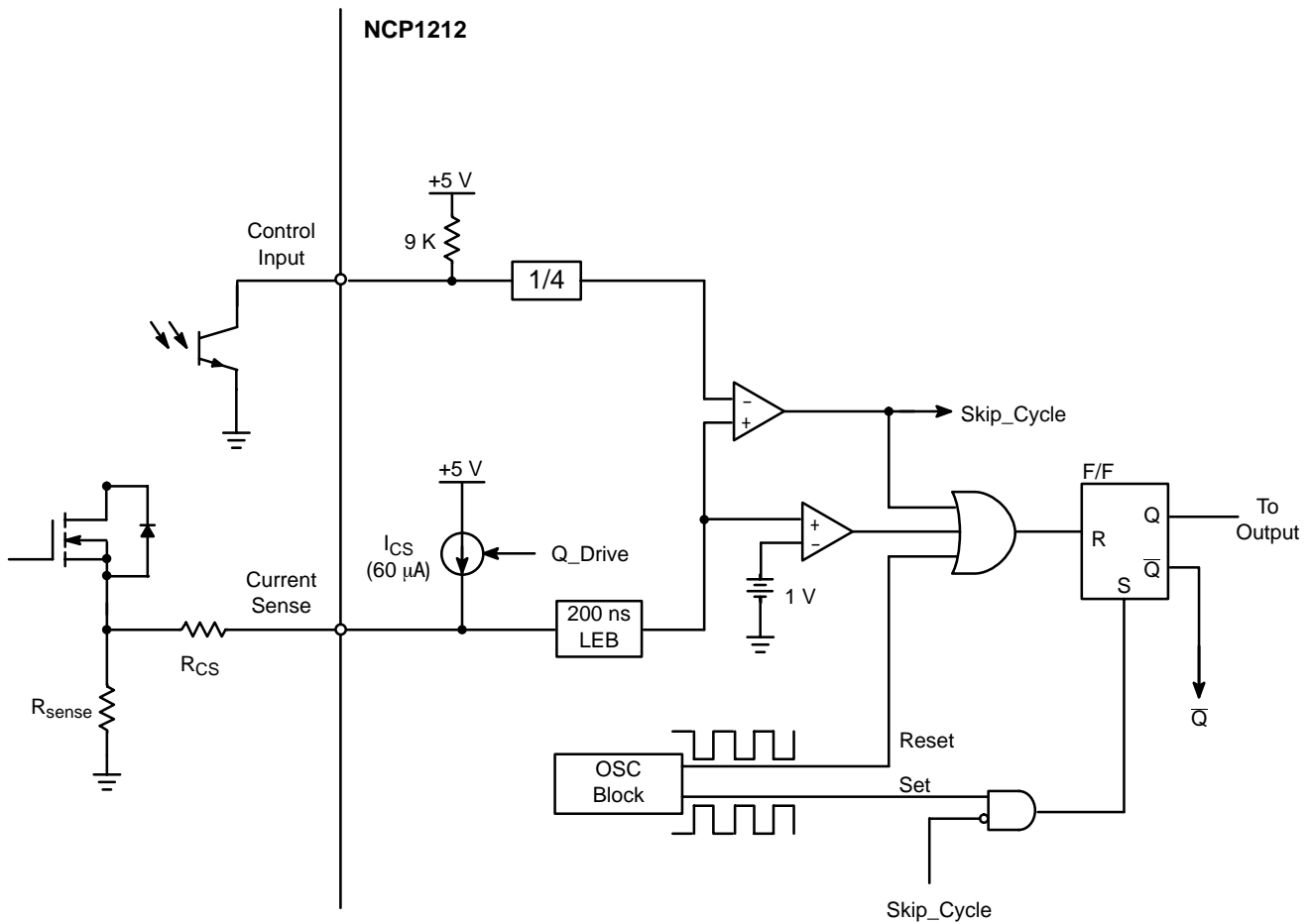

Figure 3.

Current Sense Section

The current sense input consists of a 200 ns leading edge blanking block. Thanks to that, this pin is not sensitive to the power switch turn-on noise and spikes and practically in most applications; no filtering network is required to sense the current.

For normal operation, voltage developed at the current sense input is compared with level shifted control input voltage. Output is forced to turn off if current sense voltage exceeds 1.0 V. Thus the maximum allowable peak current is given by the following equation:

$$I_{pk(max)} = \frac{1.0 V}{R_{sense}}$$

Standby Power Management (Pulse Skipping)

Every time when output is at low level, a constant current I_{CS} (60 μA typ.) flows out of the Current Sense pin. By inserting a resistor R_{CS} between the current sense resistor and Current Sense pin, an adjustable voltage is developed at the Current Sense pin. If the level shifted control input voltage is lower than the Current Sense pin voltage, the output is refrained from switching. In other words, a power

saving skip cycle mode is reached when required primary peak current fall to I_{stby} given by the following equation:

$$I_{stby} = \frac{(R_{sense} + R_{CS}) \cdot I_{CS}}{R_{sense}}$$

In practice, R_{sense} is generally much smaller than R_{CS} . Thus R_{sense} can be neglected in above equation.

$$I_{stby} = \frac{R_{CS} \cdot I_{CS}}{R_{sense}}$$

Soft-Start and Maximum Duty Selection

A constant 10 μA flows out of the Soft-Start/ D_{max} pin once V_{CC} attains the startup voltage. The capacitor connected at the pin is slowly charged up and the voltage developed plus one diode drop (V_{sst}) is compared with the sawtooth C_T waveform as shown in Figure 4. Output is turned off when C_T voltage is higher than V_{sst} . Since V_{sst} rises slowly and it controls the output duty gradually increases as shown in Figure 5. The lowest C_T voltage is at 1.0 V, there is no output before Soft-Start/ D_{max} attains about 0.4 V (1.0 V – 1 diode drop). Soft-start block will have no effect to the PWM operation once V_{sst} reaches 2.6 V.

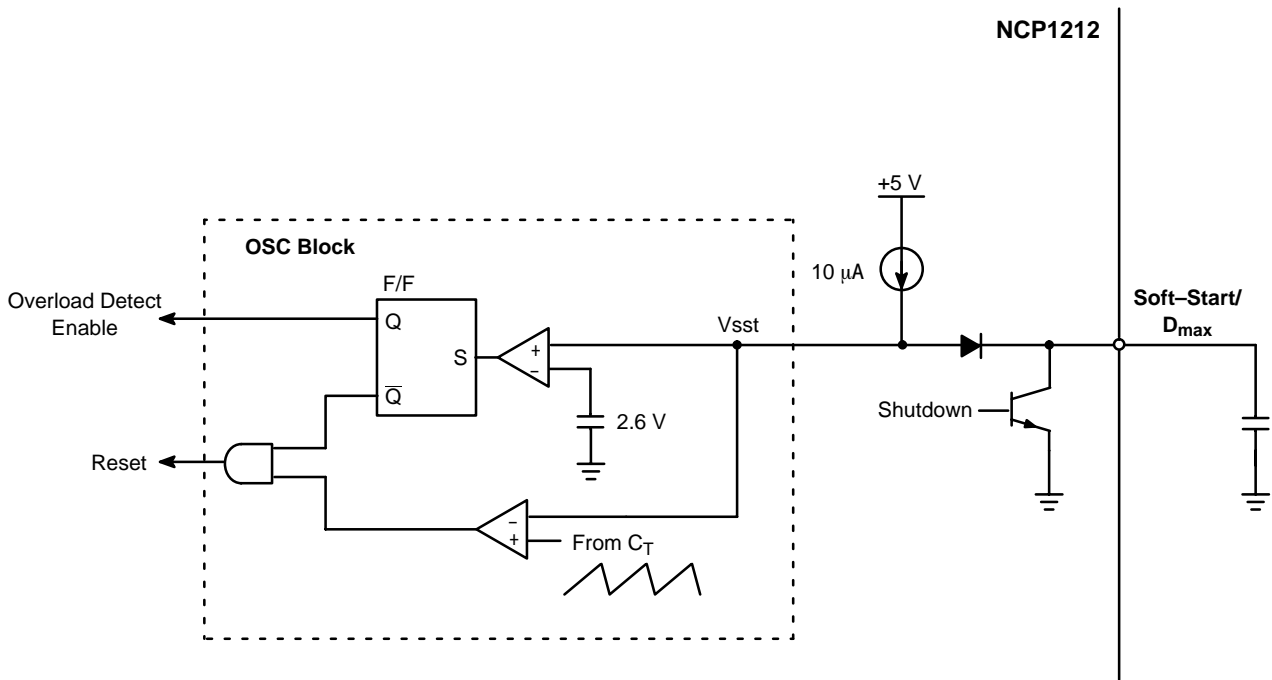

Figure 4.

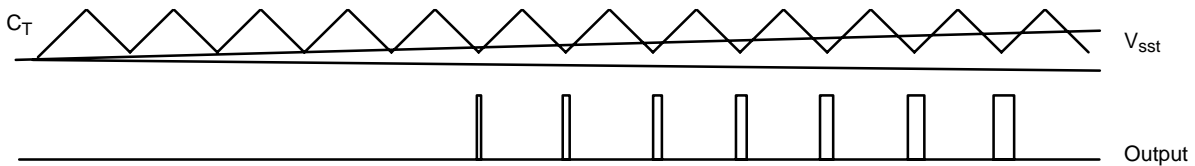

Figure 5.

Soft-Start/D_{max} pin is also used for the selection of maximum turn on duty. The oscillator circuit is designed to operate in either 80% or 50% charging time that corresponds to either 80% or 50% maximum PWM turn on duty. As discussed in the Oscillator Section, sawtooth waveform at C_T pin is different for 80% and 50% maximum turn on duty cycle and it is shown in Figure 2.

Maximum turn on duty is selected by the final voltage at Soft-Start/D_{max} pin. If 80% maximum turn on duty is desired, simply connect a capacitor from Soft-Start/D_{max} pin to ground as shown in Figure 6 and the final voltage on the capacitor is 5.0 V.

50% maximum duty is selected if the final voltage at Soft-Start/D_{max} is between 2.1 V to 2.8 V. This can be achieved by connecting a resistor in parallel with C_{SS} as shown in Figure 7.

Overload Detection

During output overload or short circuit, the PWM controller will pump as much energy as possible to the secondary and it is only cycle by cycle limited by the maximum current limit setting. Components in the power supply circuit such as the power MOSFET or output rectifier may be damaged by this continuous stress. Theoretically,

flyback converter has inherent short circuit protection provided that the PWM controller is supplied by a flyback auxiliary winding and it has UVLO function. However, it is not uncommon to experience very high leaky voltage spike that prevent V_{CC} voltage never falls below UVLO level at short circuit.

NCP1212 is equipped with overload detection mechanism which is irrespective of auxiliary winding voltage level. Overload shutdown is no longer bothered by leakage spike and a reliable overload protection system can be easily constructed by NCP1212 for both forward and flyback system. Overload detection block is shown in Figure 8. Overload condition is signified by current sense voltage hitting the maximum allowable voltage, 1.0 V. To avoid false trigger which may happen during transient load change, C_{SS} starts to discharge by 20 μA (I_{sd}-I_{ss}). If overload condition persists, V_{sst} voltage level drops to 0.5 V and triggers the overload shutdown. Overload shutdown is only enabled after the soft-start period. **Due to the overload detection mechanism, it is mandatory to connect a capacitor at the Soft-Start/D_{max} pin. Otherwise overload shutdown may be triggered during startup period.**

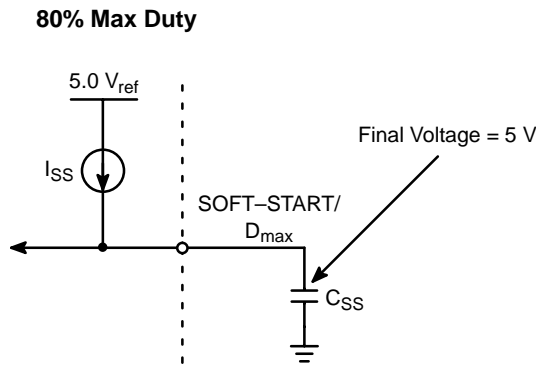

Figure 6.

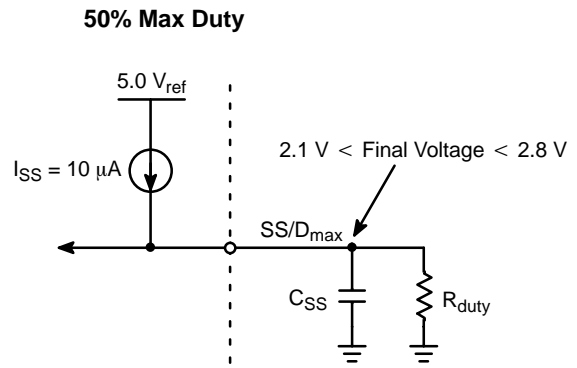

Figure 7.

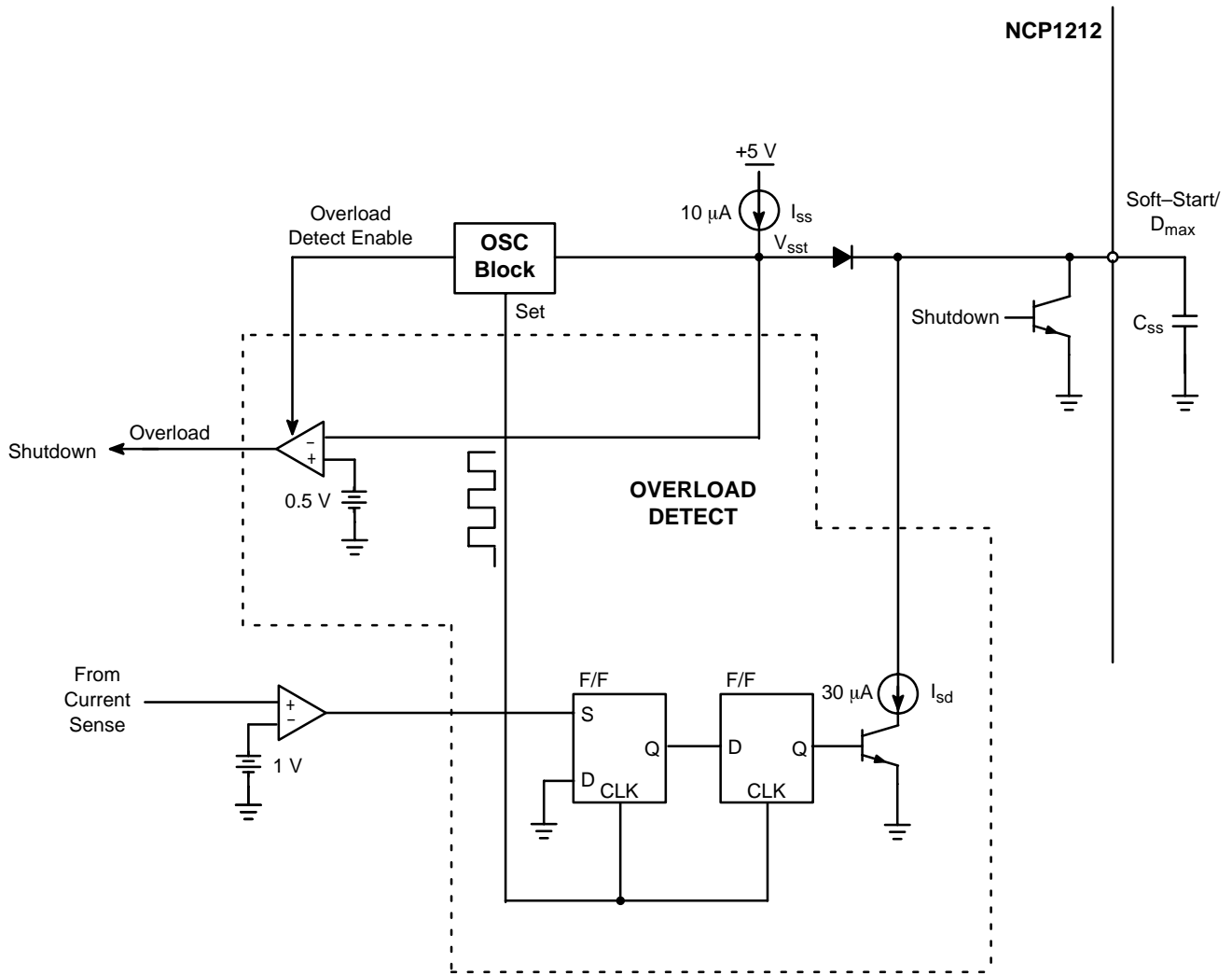

Figure 8.

Brownout Protection

NCP1212 has a built-in comparator for brownout detection as shown in Figure 9. Positive terminal of the comparator is connected to a +1.25 V bandgap reference.

The IC is prohibited from switching until Brownout Detect pin exceeds 1.25 V. Once the brownout detect threshold is exceeded, 50 μA flows out of the pin and the voltage at this pin is further pushed up to provide hysteresis effect.

NCP1212

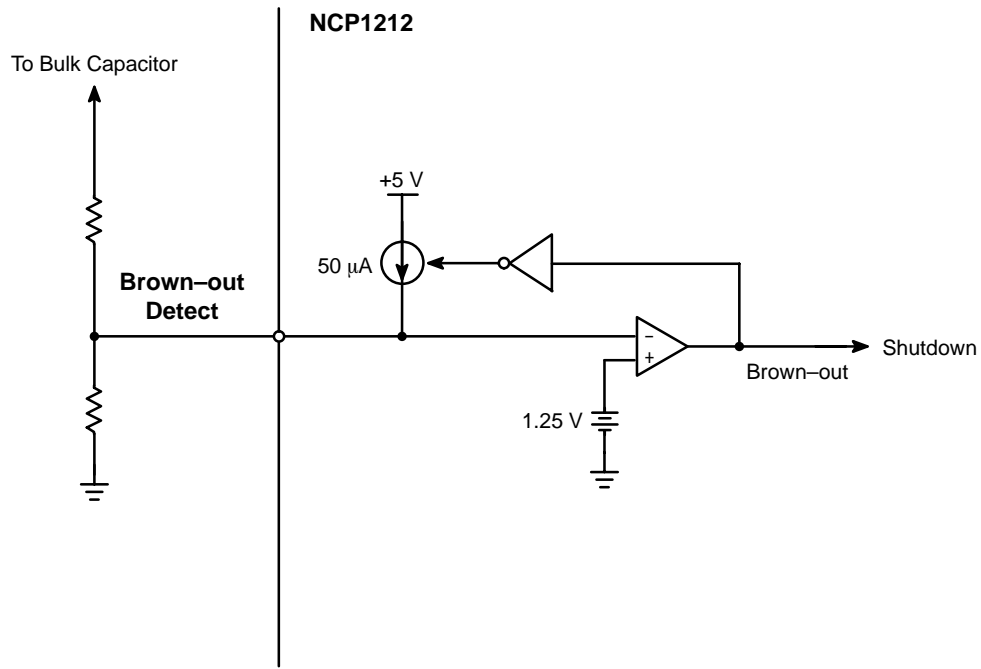

Figure 9.

V_{CC} Management

NCP1212 starts operation once V_{CC} reaches 15 V. Overvoltage protection (OVP) will be triggered if V_{CC} exceeds 25 V. Undervoltage lock out will take place if V_{CC} drops below 10 V. NCP1212 continues to draw 3.0 mA typ. after overload or overvoltage shutdown is triggered. If the startup resistance connected to V_{CC} pin is large enough such

that V_{CC} voltage keep on dropping after shutdown, NCP1212 will restart once V_{CC} drops to UVLO voltage. If the fault condition persists, NCP1212 will undergo hi-cup operation. On the other hand, one can choose latch operation by using a small startup resistance. NCP1212 will remain shutdown as long as V_{CC} is maintained above UVLO voltage after fault is detected.

NCP1212

PACKAGE DIMENSIONS

PDIP-8
P SUFFIX
CASE 626-05
ISSUE L

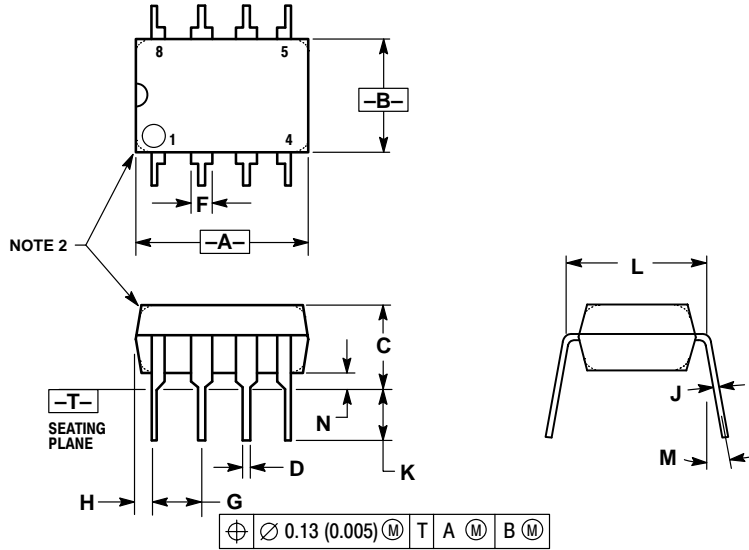

NOTES:

1. DIMENSION L TO CENTER OF LEAD WHEN FORMED PARALLEL.
2. PACKAGE CONTOUR OPTIONAL (ROUND OR SQUARE CORNERS).
3. DIMENSIONING AND TOLERANCING PER ANSI Y14.5M, 1982.

DIM	MILLIMETERS		INCHES	
	MIN	MAX	MIN	MAX
A	9.40	10.16	0.370	0.400
B	6.10	6.60	0.240	0.260
C	3.94	4.45	0.155	0.175
D	0.38	0.51	0.015	0.020
F	1.02	1.78	0.040	0.070
G	2.54 BSC		0.100 BSC	
H	0.76	1.27	0.030	0.050
J	0.20	0.30	0.008	0.012
K	2.92	3.43	0.115	0.135
L	7.62 BSC		0.300 BSC	
M	---		10°	
N	0.76	1.01	0.030	0.040

NCP1212

PACKAGE DIMENSIONS

SOIC-8
D SUFFIX
CASE 751-07
ISSUE AA

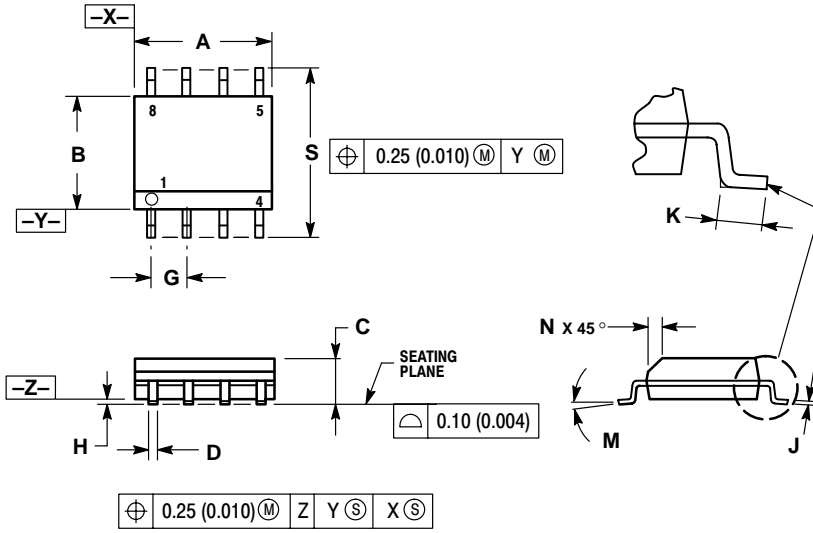

NOTES:

1. DIMENSIONING AND TOLERANCING PER ANSI Y14.5M, 1982.
2. CONTROLLING DIMENSION: MILLIMETER.
3. DIMENSION A AND B DO NOT INCLUDE MOLD PROTRUSION.
4. MAXIMUM MOLD PROTRUSION 0.15 (0.006) PER SIDE.
5. DIMENSION D DOES NOT INCLUDE DAMBAR PROTRUSION. ALLOWABLE DAMBAR PROTRUSION SHALL BE 0.127 (0.005) TOTAL IN EXCESS OF THE D DIMENSION AT MAXIMUM MATERIAL CONDITION.
6. 751-01 THRU 751-06 ARE OBSOLETE. NEW STANDARD IS 751-07

DIM	MILLIMETERS		INCHES	
	MIN	MAX	MIN	MAX
A	4.80	5.00	0.189	0.197
B	3.80	4.00	0.150	0.157
C	1.35	1.75	0.053	0.069
D	0.33	0.51	0.013	0.020
G	1.27 BSC		0.050 BSC	
H	0.10	0.25	0.004	0.010
J	0.19	0.25	0.007	0.010
K	0.40	1.27	0.016	0.050
M	0°	8°	0°	8°
N	0.25	0.50	0.010	0.020
S	5.80	6.20	0.228	0.244

ON Semiconductor and  are registered trademarks of Semiconductor Components Industries, LLC (SCILLC). SCILLC reserves the right to make changes without further notice to any products herein. SCILLC makes no warranty, representation or guarantee regarding the suitability of its products for any particular purpose, nor does SCILLC assume any liability arising out of the application or use of any product or circuit, and specifically disclaims any and all liability, including without limitation special, consequential or incidental damages. "Typical" parameters which may be provided in SCILLC data sheets and/or specifications can and do vary in different applications and actual performance may vary over time. All operating parameters, including "Typicals" must be validated for each customer application by customer's technical experts. SCILLC does not convey any license under its patent rights nor the rights of others. SCILLC products are not designed, intended, or authorized for use as components in systems intended for surgical implant into the body, or other applications intended to support or sustain life, or for any other application in which the failure of the SCILLC product could create a situation where personal injury or death may occur. Should Buyer purchase or use SCILLC products for any such unintended or unauthorized application, Buyer shall indemnify and hold SCILLC and its officers, employees, subsidiaries, affiliates, and distributors harmless against all claims, costs, damages, and expenses, and reasonable attorney fees arising out of, directly or indirectly, any claim of personal injury or death associated with such unintended or unauthorized use, even if such claim alleges that SCILLC was negligent regarding the design or manufacture of the part. SCILLC is an Equal Opportunity/Affirmative Action Employer.

PUBLICATION ORDERING INFORMATION

Literature Fulfillment:

Literature Distribution Center for ON Semiconductor
P.O. Box 5163, Denver, Colorado 80217 USA
Phone: 303-675-2175 or 800-344-3860 Toll Free USA/Canada
Fax: 303-675-2176 or 800-344-3867 Toll Free USA/Canada
Email: ONlit@hibbertco.com

N. American Technical Support: 800-282-9855 Toll Free USA/Canada

JAPAN: ON Semiconductor, Japan Customer Focus Center
4-32-1 Nishi-Gotanda, Shinagawa-ku, Tokyo, Japan 141-0031
Phone: 81-3-5740-2700
Email: r14525@onsemi.com

ON Semiconductor Website: <http://onsemi.com>

For additional information, please contact your local Sales Representative.