

33. ANTI THEFT CONTROL SYSTEM CIRCUIT

1) NOTCH BACK

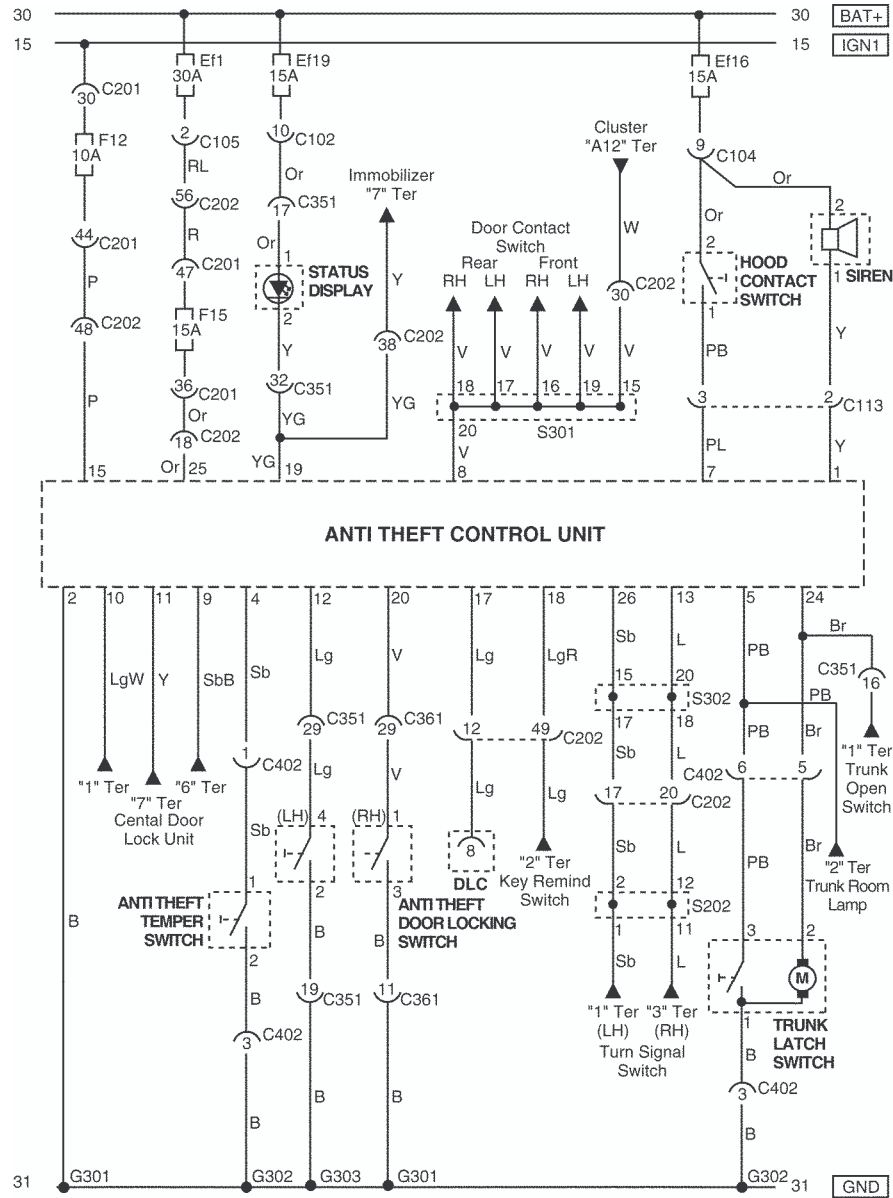

J3D15083

a. CONNECTOR INFORMATION

CONNECTOR(No.) (PIN NO. COLOR)	CONNECTING, WIRING HARNESS	CONNECTOR POSITION
C102 (11 Pin, White)	Body – Engine Fuse Block	Engine Fuse Block
C104 (24 Pin, White)	Front – Engine Fuse Block	Engine Fuse Block
C105 (4 Pin, White)	Body – Engine Fuse Block	Engine Fuse Block
C113 (16 Pin, Black)	Body – Front	Behind ECM Bracket
C201 (76 Pin, Black)	I.P – I.P Fuse Block	I.P Fuse Block
C202 (89 Pin, White)	I.P – Body	Left Driver Leg Room
C351 (33 Pin, Gray)	Body – Front Light Door	Under Driver A Pillar
C361 (33 Pin, Gray)	Body – Front Right Door	Under Co-Driver A Pillar
C402 (6 Pin, White)	Trunk LID – Body	Inside Right Trunk Side Cover
S202 (Black)	I.P	Behind Cluster
S301 (Blue)	Body	Left Driver Leg Room
S302 (Brown)	Body	Left Driver Leg Room
G301	Body	Below Co-Driver Cross Member Floor Panel
G302	Body	Below Left C Pillar
G303	Body	Below Left Driver Leg Room

b. CONNECTOR IDENTIFICATION SYMBOL & PIN NUMBER POSITION

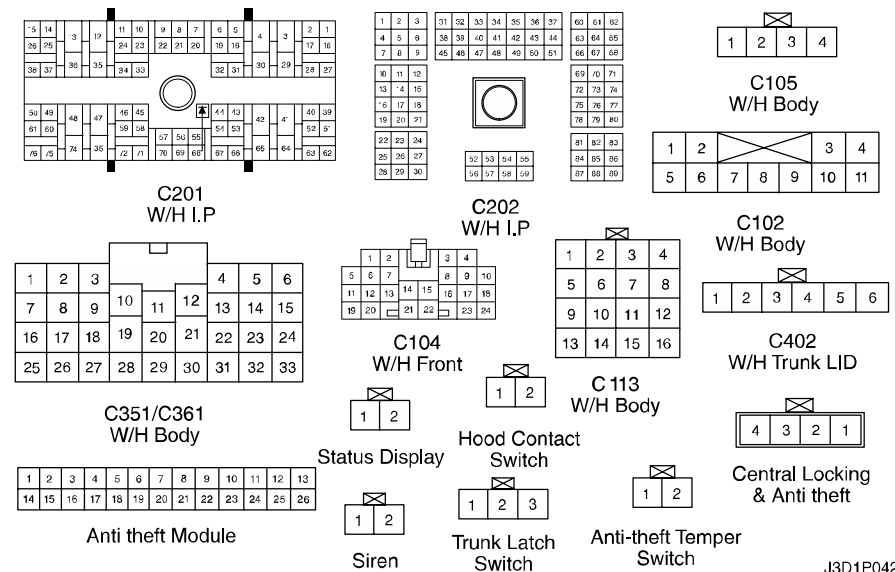

J3D1P042

c. POSITION OF CONNECTORS AND GROUNDS

- W/H BODY

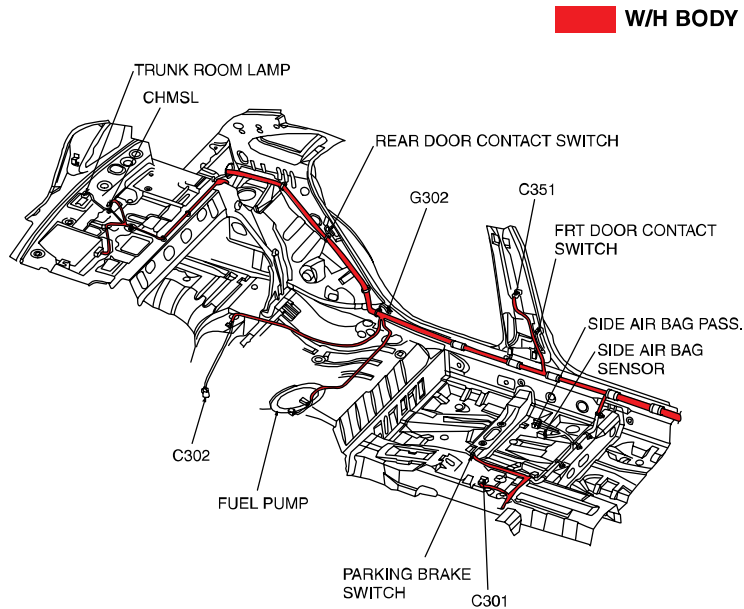

J3B12016

d. SPLICE PACK

S202

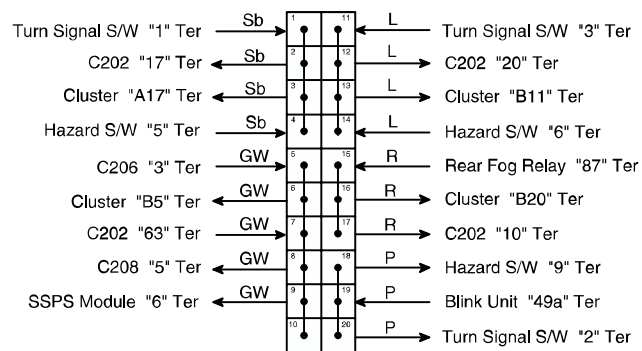

J3D1S003

S301

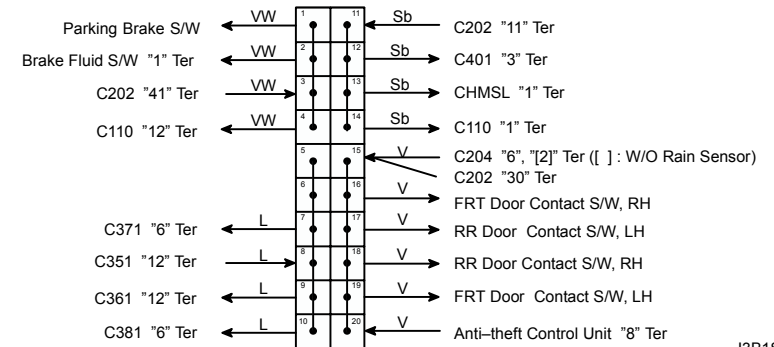

J3B1S008

S302

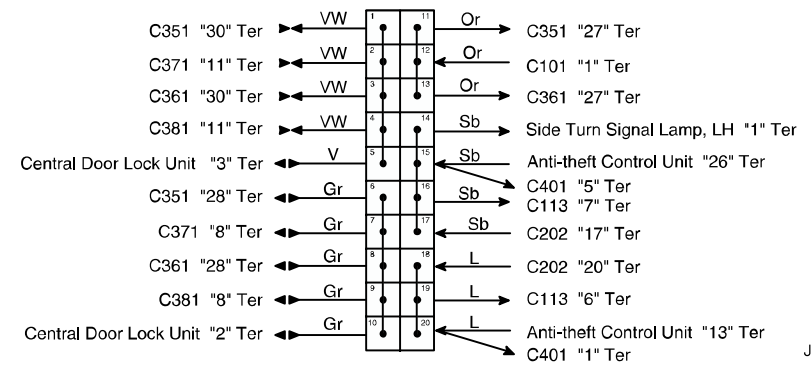

J3D1S005

2) HATCH BACK

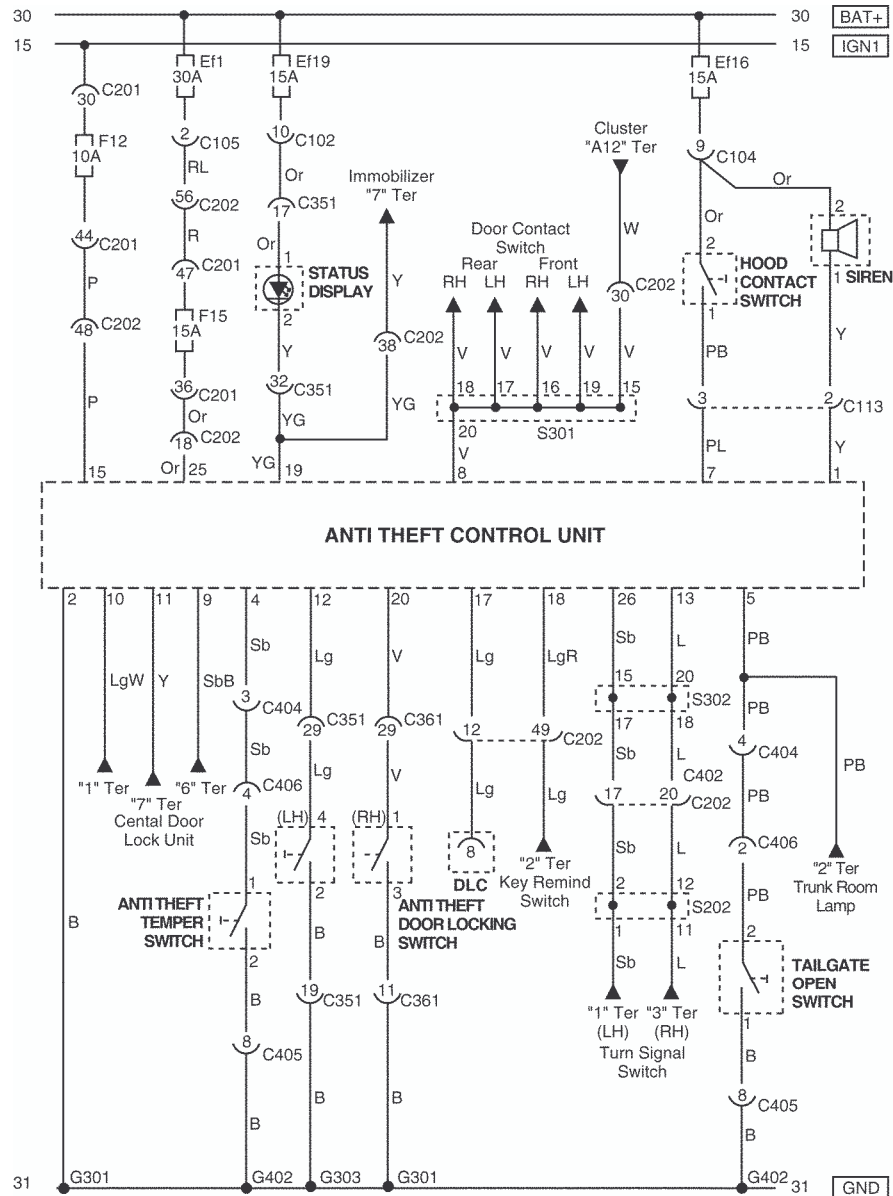

J3D15084

a. CONNECTOR INFORMATION

CONNECTOR(NO.) (PIN NO. COLOR)	CONNECTING, WIRING HARNESS	CONNECTOR POSITION
C102 (11 Pin, White)	Body – Engine Fuse Block	Engine Fuse Block
C104 (24 Pin, White)	Front – Engine Fuse Block	Engine Fuse Block
C105 (4 Pin, White)	Body – Engine Fuse Block	Engine Fuse Block
C113 (16 Pin, Black)	Body – Front	Behind ECM Bracket
C201 (76 Pin, Black)	I.P – I.P Fuse Block	I.P Fuse Block
C202 (89 Pin, White)	I.P – Body	Left Driver Leg Room
C351 (33 Pin, Gray)	Body – Front Light Door	Under Driver A Pillar
C361 (33 Pin, Gray)	Body – Front Right Door	Under Co-Driver A Pillar
C404 (8 Pin, White)	T/Gate. EXT. – Body	Inside Left C Pillar
C405 (8 Pin, White)	T/Gate. EXT. – T/Gate	Beside Left Rear Wiper Motor
C406 (6 Pin, White)	T/Gate. EXT. – T/Gate	Beside Left Rear Wiper Motor
S202 (Black)	I.P	Behind Cluster
S301 (Blue)	Body	Left Driver Leg Room
S302 (Brown)	Body	Left Driver Leg Room
G301	Body	Below Co-Driver Cross Member Floor Panel
G303	Body	Below Left Driver Leg Room
G402	T/Gate. EXT	Inside Driver C Pillar

b. CONNECTOR IDENTIFICATION SYMBOL & PIN NUMBER POSITION

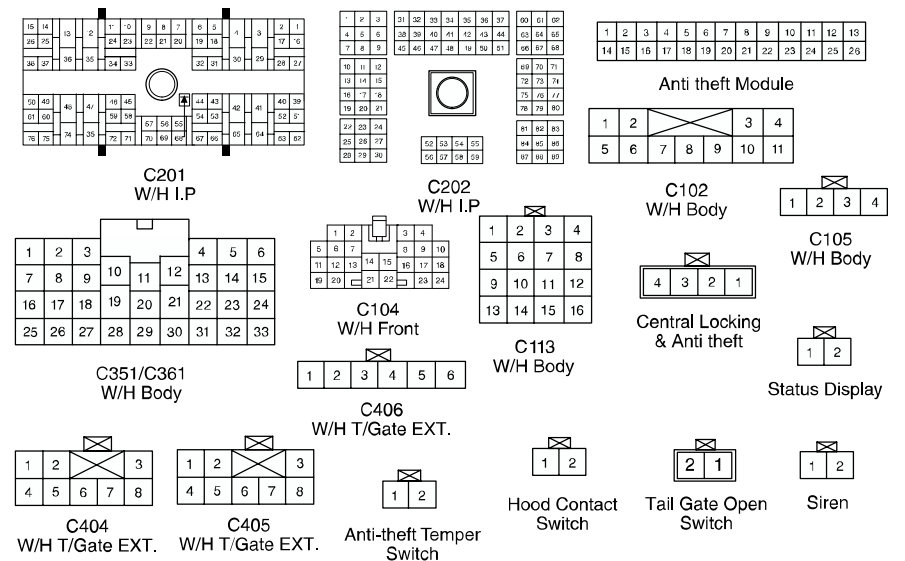

J3D1P043

c. POSITION OF CONNECTORS AND GROUNDS

- W/H BODY

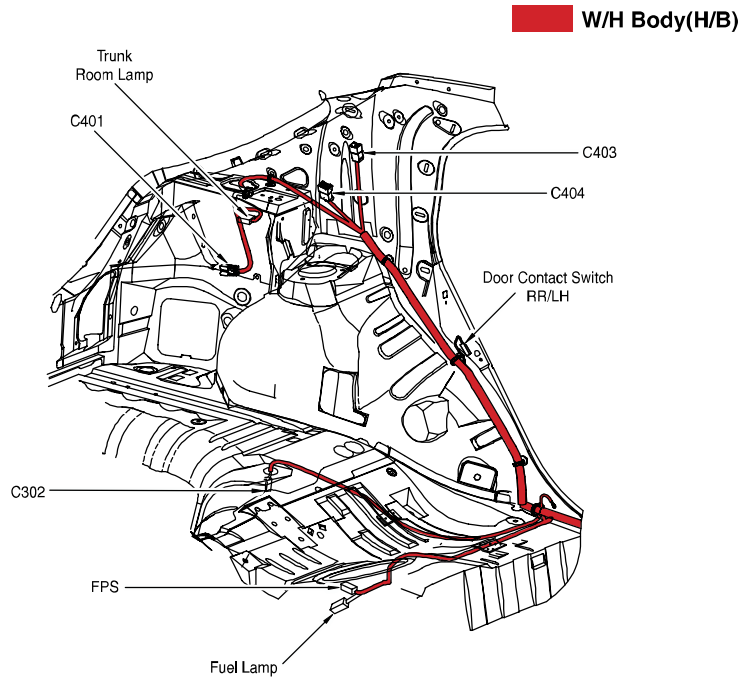

J3B12029

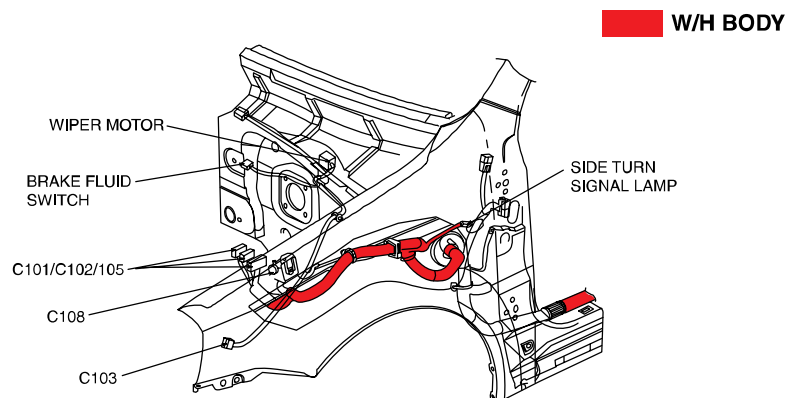

J3B12020

d. SPLICE PACK

S202

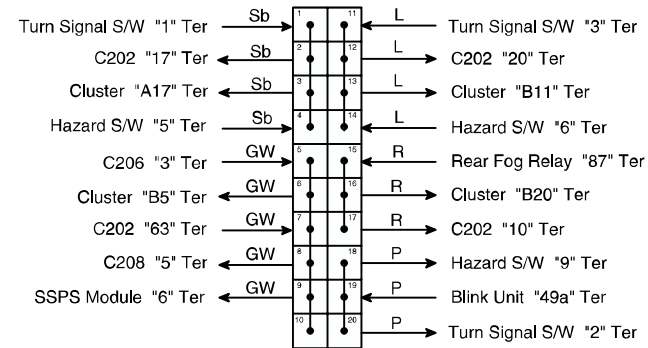

J3D1S003

S301

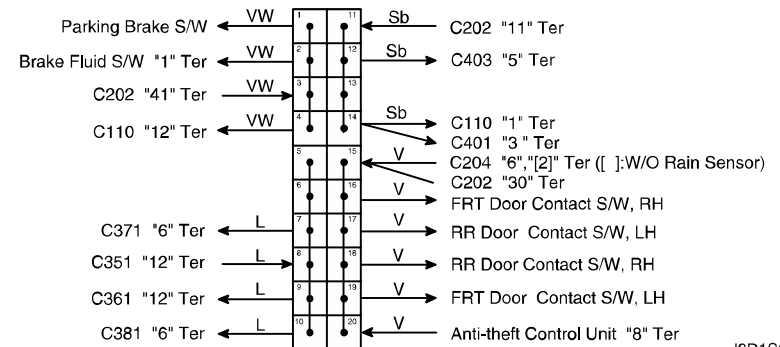

J3D1S006

S302

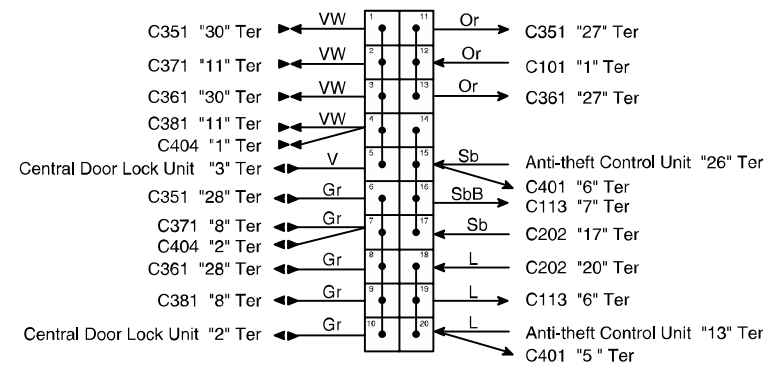

J3D1S007