

Manganese Lithium Coin Batteries (ML series): Individual Specifications

ML414

□ Dimensions(mm)

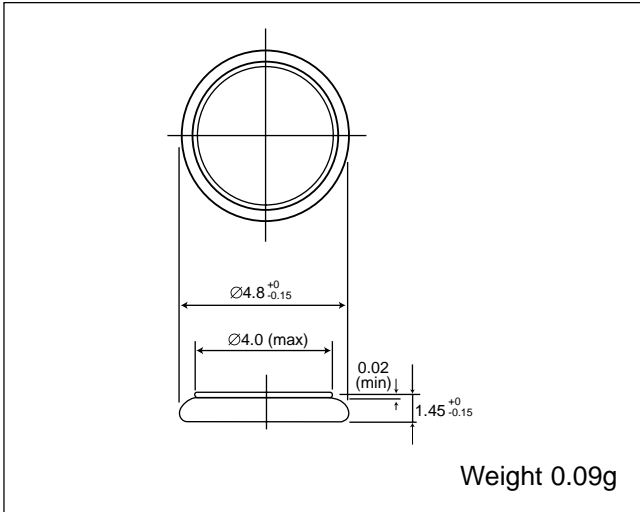

□ Specification

Nominal voltage (V)	3
Nominal capacity (mAh)	1.2
Continuous standard load (mA)	0.005
Operating temperature (C)	-20 ~ +60

□ Discharge characteristics

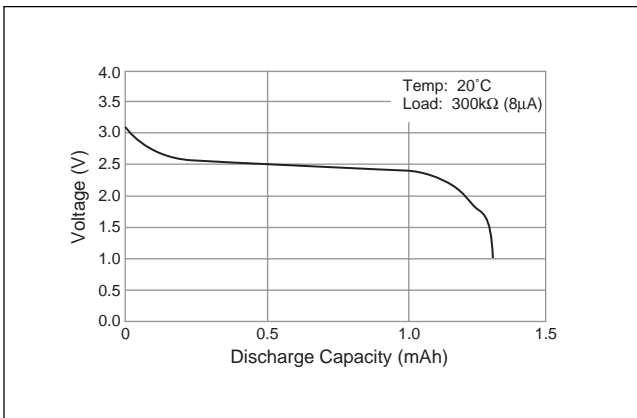

□ Consumption current vs. Duration time

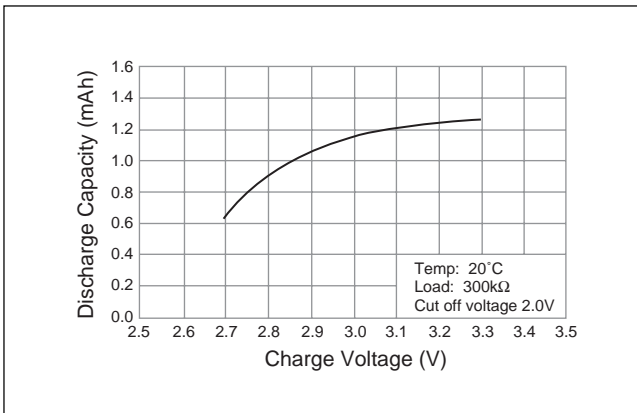

ML421

□ Dimensions(mm)

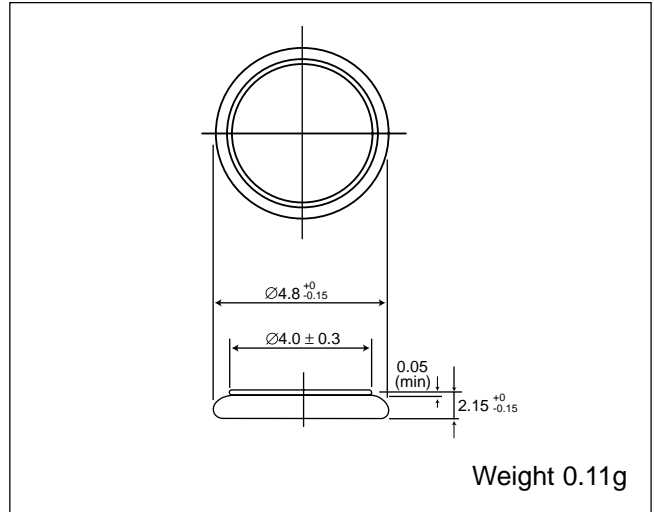

□ Specification

Nominal voltage (V)	3
Nominal capacity (mAh)	2.3
Continuous standard load (mA)	0.003
Operating temperature (C)	-20 ~ +60

□ Discharge characteristics

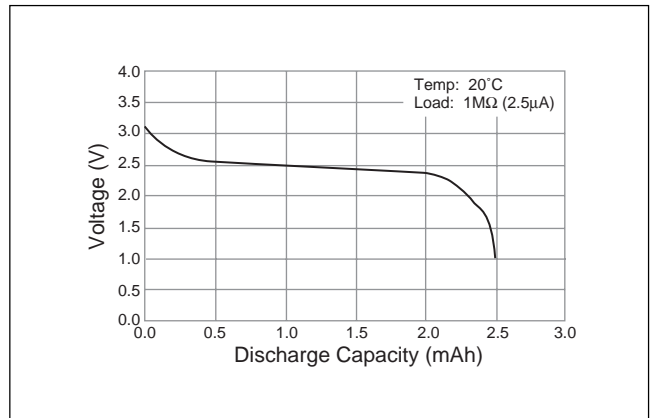

□ Consumption current vs. Duration time

