

**TUMBLE DRYER**

---

|             |  |              |           |
|-------------|--|--------------|-----------|
| <b>I.</b>   | <b>SAFETY INFORMATION</b>                              | <b>Page</b>  | <b>1</b>  |
| <b>II.</b>  | <b>OPERATION</b>                                       | <b>Seite</b> | <b>1</b>  |
| <b>III.</b> | <b>DESCRIPTION OF FUNCTION/TECHNICAL INFORMATION</b>   | <b>PAGE</b>  | <b>13</b> |
| <b>IV.</b>  | <b>CONSUMPTION RATES/ENERGY REQUIREMENT/OTHER DATA</b> | <b>PAGE</b>  | <b>15</b> |
| <b>V.</b>   | <b>REPAIRS</b>   | <b>Page</b>  | <b>19</b> |
| <b>VI.</b>  | <b>SUPPLEMENTS</b>                                     | <b>Page</b>  | <b>30</b> |

---

**I. SAFETY INSTRUCTIONS****1. Safety test**

- Plug in the tester mains plug.

In the case of switchover models connect L1 and L2 on the tester.

- Switch on the appliance (door must be closed).
- Perform the test.

**II. OPERATION****2. Features**

- One or two-control operation – Programme selector for degrees of dryness/timed programme,
  - Cottons/Coloureds – 6 humidity-controlled programmes,
  - Easy-care – 5 humidity-controlled programmes,
  - 2 special programmes – wool care, smoothing,
  - Timed programmes – cold / warm max. 90 min.,
  - 6 buttons – On/Off, Open door, Low heat, Select, Change,
  - Programme progress indicator via LEDs – Dry / Iron dry / Cupboard dry / Extra dry / Protection against creasing / End,
  - Programme progress indicator,
  - "Empty container" LED for condensation detection function in the base group (only condenser dryers).
  - "Clean filter" LED for status detection of fluff filter and cooler.
-



### 3. Time remaining display

- A fixed programme duration is assigned to each drying programme (5 kg load).
- Irrespective of the load and the initial residual humidity, the permanently stored time is displayed after the programme has started.
- Differences between the displayed and actual drying time are possible due to different and multi-layered textiles and the varying spin power of the washing machine.
- The estimated remaining time is displayed in the 7-segment display after the programme has been selected and the "Start" button pressed.
- The remaining time counts down in minutes from the start of the subsequent timed redrying procedure (according to the set degree of dryness and any individual precision adjustment of the drying setting); the remaining time is displayed precise to one minute.

### 4. Control logic – selection of the functions (indicated in the 7-segment display)

#### 4.1 Preselecting the starting time (max. 19 hours)

1. Switch on appliance,
2. Set the programme selector to the desired degree of dryness,
3. After pressing the "Select" button once, **A1** is indicated in the 7-segment display,
4. Press the "Change" button repeatedly (within 4 seconds) to preselect the appropriate start time. If the set start time is not changed within 4 seconds ("Change" flashes), the set value is stored ("Change" off),
5. Press the Start button – the "Start" LED glows.

**Preselection of starting time is active when the "Start" LED glows and a dot flashes in the 7-segment display.**

**Warning!!!** If the programme is changed with the selector switch, the preselected start time is switched off. The "Start" LED flashes – the programme can be started by pressing the "Start" button.

**Warning!!!** If the door is opened and closed again (top up washing), the preselected start time is interrupted – the "Start" LED flashes. To reactivate the preselected start time, press the "Start" button – the "Start" LED glows.

After a prolonged power failure (> 2 hours), the preselected start time is deleted, the "Start" LED flashes.

Bei Netzausfall (< 2 Stunden) startet das eingestellte Programm sofort.



## 4.1.1 Adjusting the signal volume

1. Switch on appliance,
2. Press the "Select" button 2x – **A2** is indicated in the 7-segment display,
3. After approx. 2 seconds the set volume is indicated in the 7-segment display  
3 = loud    2 = medium    1 = quiet    0 = off
4. Select the volume by pressing the "Change" button.

When the signal has been set, an acoustic signal is emitted at the end of the programme (for approx. 1 min.).

## 4.1.2 Individual precision adjustment of the drying settings

A precision adjustment can adjust the degree of dryness to ambient and installation conditions (e.g. water hardness). On reaching the degree of dryness, the washing is redried for a preset time depending on the selected setting.

Setting the individual precision adjustment:

1. Switch on appliance,
2. Press the "Select" button 3x – **A3** is indicated in the 7-segment display, after approx. 2 seconds the selected drying setting (factory setting 0 = neutral).

|         | Exhaust air | Air condensation |
|---------|-------------|------------------|
| Level 0 | Neutral     | Neutral          |
| Level 1 | +4 minutes  | + 5 minutes      |
| Level 2 | +8 minutes  | +10 minutes      |
| Level 3 | +12 minutes | +15 minutes      |
| Level 4 | +16 minutes | + 20 minutes     |

3. Press the "Change" button according to the required setting 0–4. The "Change" LED flashes – when the LED goes out, the selected drying setting has been set.

## 4.1.3 Inputting the spin speed of the washing machine

To display the estimated remaining time as precisely as possible, the utilised spin speed should be input.

Inputting the spin speed of the washing machine:

1. Switch on appliance,
2. Press the "Select" button 4x – **A4** is indicated in the 7-segment display, after approx. 2 seconds the factory set value of "10" is indicated for 1000 r.p.m.
3. Press the "Change" button until the desired value is indicated in the display field.  
8 = 800 r.p.m.    10 = 1000r.p.m.    12 = 1200 r.p.m.n    14 = 1400 r.p.m.    16 = 1600 r.p.m.



### 4.1.4 Locking the appliance to prevent unauthorised use

To prevent unauthorised use (e.g. in communal laundries), the appliance can be locked via the electronics module.

The appliance can no longer be started – when the dryer is switched off, the lock remains intact.

It is not possible to lock a programme while it is running.

#### Inputting the electrical lock:

1. Switch on the appliance
2. Hold down the "Select" button (for at least 6 seconds) – "—" id indicated in the 7-segment display.

#### Removing the lock:

1. Switch on the appliance
2. Hold down the "Select" button (for at least 6 seconds) – wait until "—" goes out.

### 4.1.5 Demo programme for the trade

The demo programme can be selected for exhibition purposes.

#### Sequence:

- All LED blocks illuminate once
- A humidity controlled programme (without remaining time) runs
- The remaining time is displayed with the count-down of a timed programme
- Actuation of the Option buttons (LEDS illuminate only briefly) or Speed switch have no effect on the progress of the demo programme.
- The duration of the demo programme is not restricted – the cycle is repeated every 2 minutes.
- Heater and motor are not actuated during the demo programme
- The demo programme is terminated by switching off the appliance

#### Selecting the demo programme:

1. Switch on appliance,
2. Press the "Select" button 5x, "A5" is indicated in the 7-segment display, after approx. 2 seconds the display changes to "OF"
3. Press the "Change" button – the display changes to "On" – the demo programme starts.



5. Table of programmes

| <b>Cottons/Coloureds</b> made of cotton or linen up to max. 5 kg |  | <b>Electronic programme</b>  |
|--|--|--|
| Extra dry  | Terry dressing gowns and bed linen<br>No underwear or socks                  | Especially thick and multi-ply materials                               |
| Very dry   | Terry cloths, tea towels and hand towels, bed linen, underwear, cotton socks | For laundry which is not to be ironed, with thick, multi-ply materials |
| Cupboard dry*  | Terry cloths, tea towels and hand towels, bed linen, underwear, cotton socks | For laundry which is not to be ironed.                                 |
| Lightly dry  | T-shirts, sports shirts, dresses, trousers, overalls, underwear              | For laundry which is not to be ironed or only lightly ironed           |
| Iron dry*  | Bed and table linen, towels, T-shirts, sports shirts, overalls               | For laundry which is to be ironed                                      |
| Rotary iron dry  | Bed and table linen, towels  | For laundry which is to be mangled                                     |

| <b>Easy-care</b> (drip-dry) laundry made of synthetic and blended fabrics as well as cotton with drip-dry fabric finish<br>e.g. viscose, cupro, modal, polyester up to max. 2.5 kg.<br>If textiles are very temperature-sensitive, e.g. polyacryl, polyamide, elastane, acetate, press the "Low heat" button. |  | <b>Electronic programme</b> |
|---|--|-----------------------------|
|---|--|-----------------------------|

|               |   |  |
|---------------|---|--|
| Extra dry     | Anoraks, blankets   | Especially thick and multi-ply materials   |
| Very dry      | Bed and table linen, track suits  | For laundry which is not to be ironed or only lightly ironed, with thick and multi-ply materials |
| Cupboard dry* | Shirts, blouses, sportswear   | For laundry which is not to be ironed.   |
| Lightly dry   | Dresses, skirts, trousers, shirts, blouses, corsetry, leggings, synthetic-rich sportswear | For laundry which is not to be ironed or only lightly ironed                                     |
| Iron dry*     | Trousers, dresses, skirts, shirts   | For laundry which is to be ironed  |



**Timed programme – max. 90 min.**

|   |   |
|---|---|
| Predried textiles with low moisture content and/or individual small laundry items up to 1 kg<br>If textiles are very temperature-sensitive, press the "Low heat" button!                                    | <b>Timed programme warm</b>                       |
| All textiles<br>Freshens up little worn items of clothing, removes creases from damp textiles which should not be dried in the dryer.   | <b>Cold</b>                                       |
| Suitable for cotton or linen fabrics, easy-care textiles made of cotton, blended or synthetic fabrics.<br>Creases in textiles from previous spin cycle are reduced.<br>Textiles are <b>not</b> dried ready. | <b>Special programmes</b><br><br><b>Smoothing</b> |
| Suitable for wool textiles.<br>Textiles are fluffy but <b>not</b> dry.  | <b>Wool care</b>                                  |

\* According to the test programmes in compliance with IEC 1121 / EN 61121

The "Low heat" button must be pressed for sensitive textiles, e.g. acrylic fibres. The temperature is reduced and the drying time is extended slightly.

Programme progress indicator via LEDs – Drying Iron dry Anti-creasing/End

**6. Selecting the programme**

Are the following settings possible via the "Select" button?

- A1** Preselection of starting time (1–19 h)
- A2** Adjustment of signal (volume –3 loud –2 medium –1 quiet –0 off)
- A3** Individual precision adjustment of drying setting
- A4** Adjustment of spin speed
- A5** Demo programme for the trade

Selection:

1. Switch on appliance,
2. Select the degree of dryness (electronic or timed programme),  
if required, select options
3. Press the "Start" button – appliance starts – estimated remaining time is indicated in the 7-segment display.

**"Low heat" button**

The "Low heat" button must be pressed for sensitive textiles which have a high synthetic fibre content, e.g. acrylic fibres (observe care instructions). The temperature is reduced and the drying time is extended slightly.



## 7. Programme sequence

The moisture in the laundry is constantly monitored by an electronic scanning system (conductivity measurement). The programme status is indicated by LEDs.

End of programme/Anti-creasing 35 minutes.

The selected degree of dryness is determined by a conductivity measurement. The conductivity measurement of the laundry is reduced to a voltage measurement.

- If error messages occur:  
8 x 0.3 sec. On; approx. 9 sec. pause / repeat without time restriction

## 8. Components

### 9. Operating module

The operating module inputs and outputs information. One or two programme selector switches, micro-buttons, loudspeaker and LEDs are situated on the operating module (depending on model).

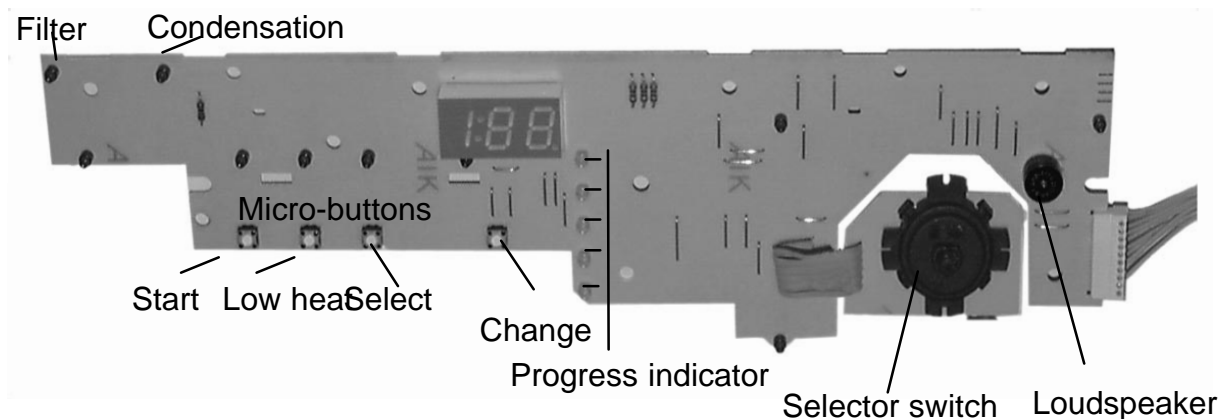

The red "Empty tank" LED on vented dryers has no function and is covered by the panel.

## 10. Control and power module

The module houses all the important components, e.g. micro-controller, relays, power supply, etc. It performs complex functions with respect to controlling drying sequences, monitoring the temperature, ascertaining parameters and actuating the operating and display section.

The appliance is switched over from 16 A to 10 A via software.



**10 A/16 A adjustment**

Hold down the "Start" and "Low heat" buttons and switch on the appliance.  
 The "Start" LED flashes at double the frequency  
 10 or 16 is indicated in the 7-segment display.

|            |                    |                             |
|------------|--------------------|-----------------------------|
| <b>10A</b> | "Low heat" LED off | 7-segment display <b>10</b> |
| <b>16A</b> | "Low heat" LED on  | 7-segment display <b>16</b> |

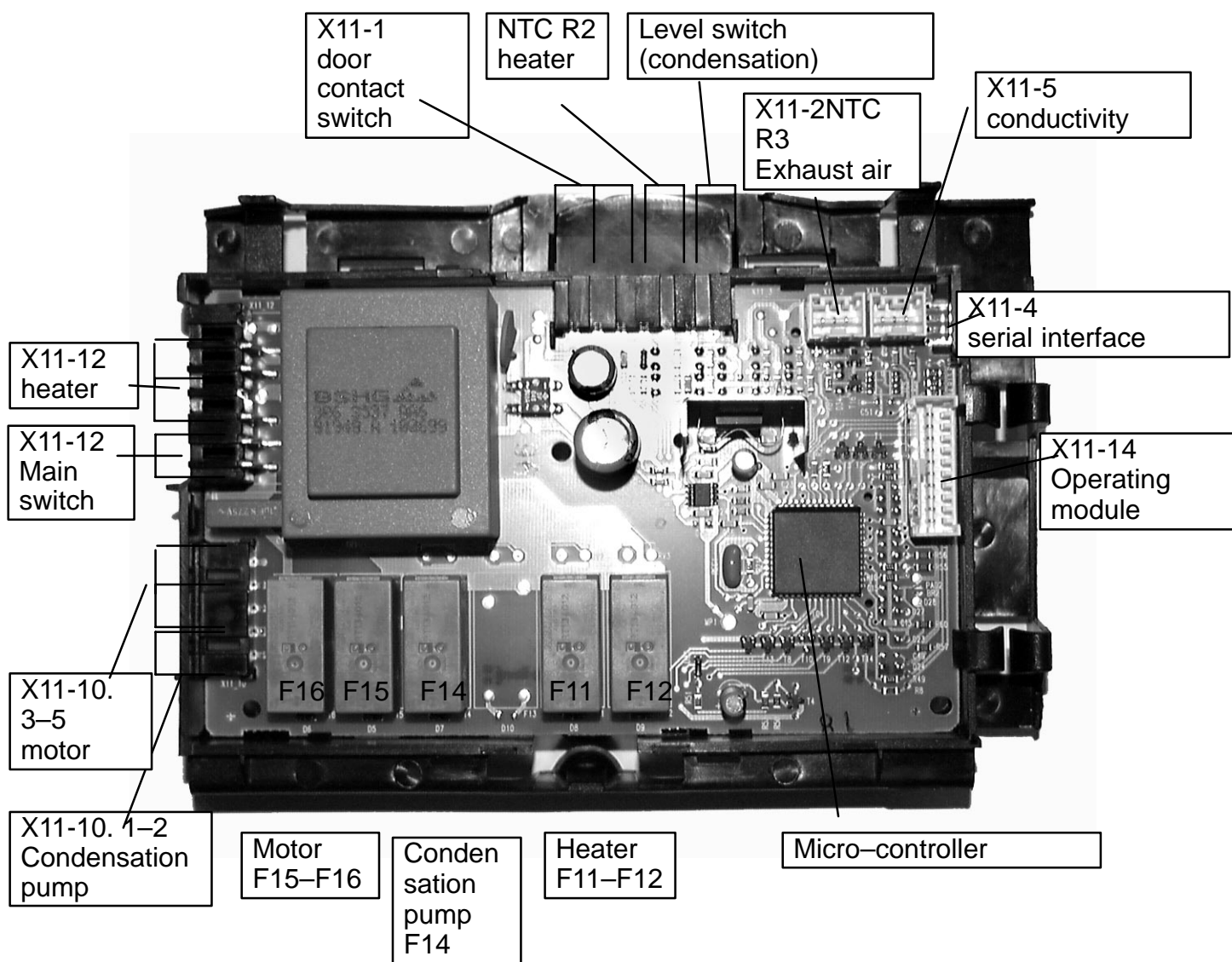

Specifications

Nominal voltage 230 VAC  
 Permitted operating voltage range 195... 253 VAC  
 Nominal frequency 50 Hz  
 Permitted frequency range 45... 65 Hz





## 11. Thermistor sensor for measuring the air temperature

Thermistor sensors measure the temperature of the process air at two points in the appliance (NTC thermistor – NTC stands for Negative Temperature Coefficient).

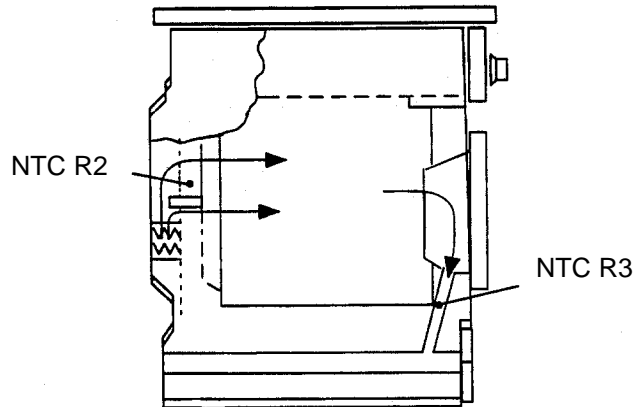

### NTC R3

is situated in the ring insert under the door and measures the exhaust-air temperature. The NTC sensor is actuated by 5 V from the control and power electronics. The Sensor consists of a 4 mm diameter Ni-ro steel sleeve. The NTC pellet is embedded in the tip.

Resistance values:

| Temperature<br>°C | Resistance<br>kΩ |
|-------------------|------------------|
| 20                | approx. 12,5     |
| 30                | approx. 8        |
| 40                | approx. 5,3      |
| 50                | approx. 3,6      |
| 60                | approx. 2,5      |
| 70                | approx. 1,7      |
| 80                | approx. 1,2      |

### NTC R2

is situated above the heater and measures the temperature of the air blown into the washing.

The sensor consists of a 23 mm long heat-resistant plastic sleeve and is attached to the sensor flange with reinforced sheet-metal brackets in the heating element.



Resistance values:

| Temperature<br>°C | Resistance<br>kΩ |
|-------------------|------------------|
| 20                | approx. 25       |
| 30                | approx. 16       |
| 40                | approx. 10,6     |
| 50                | approx. 7,2      |
| 60                | approx. 5,0      |
| 70                | approx. 3,5      |
| 80                | approx. 2,5      |
| 90                | approx. 1,8      |
| 100               | approx. 1,3      |
| 110               | approx. 1,0      |
| 120               | approx. 0,8      |
| 130               | approx. 0,6      |
| 140               | approx. 0,47     |
| 150               | approx. 0.37     |

## 12. Main switch with Open door button

The main switch with Open door button is a 2-pole, latching switch for switching on/off the appliance and a mechanism for actuating the Bowden cable which opens the door.

If the "Door" button is pressed, the Bowden cable actuates the door mechanism and the door opens. At the same time the 2-pole switch is opened and the control and power module is isolated from the power supply.

### Specifications

Nominal voltage 250 VAC

Max. operating current: 16 (4) A

## 13. Float switch (condensation only)

The float switch is latched to the float holder. The gold-plated make contact is designed for small currents at **5V-**.

When the level is detected in the base pan, the switching contact is actuated. The power and control module changes the clock frequency of the condensation pump and switches off the heater. If the contact is still closed after 120 sec., "Empty tank" is displayed on the fascia and the programme ends 90 min. later.

### Specifications

1 gold-plated make contact

Low actuation forces

Max. permitted contact resistance  $\leq 1.5$  ohm when  $I = 1.3$  mA



**14. Condensation pump (condensation only)**

The condensation pump is situated in the base group underneath the belt tensioning device (transmission) and conveys the accumulating condensation upwards into the condensation water tank.

Specifications

|                                   |                 |             |
|-----------------------------------|-----------------|-------------|
| Nominal operating voltage         | 230 VAC         |             |
| Permitted operating voltage range | 195 ... 244 VAC |             |
| Nominal frequency                 | 50 Hz           |             |
| Permitted frequency range         | 48 ... 52 Hz    |             |
| Starting voltage                  | 150 V           |             |
| No-load speed                     | 2300 r.p.m.     |             |
| No-load current                   | min. 145 mA     | max. 175 mA |
| Load current                      | max. 400 mA     |             |
| Winding resistance                | 123 ohm         |             |

Delivery rate:

The delivery rate is at a constant water level of 30 mm and an inner hose diameter of 7.0 mm

|                      | Delivery rate Q (l/min) |            |
|----------------------|-------------------------|------------|
|                      | at 195 VAC              | at 230 VAC |
| 1,00 m delivery head | 1,5                     | 2,5        |
| 1.20 delivery head   | 1,0                     | 1,5        |

ON duration:

The pump is clocked by the electronic controller at fixed pumping times. The cycle times are: 30 sec. pump **on** – 90 sec. pump **off**. If the float switch is actuated, the cycle times change: 90 sec. pump **on** – 30 sec. **off**.

**15. Exhaust-air motor**

The motor drives the drum and the fan.

Specifications

|  |                |
|--|----------------|
| Supplier   | SISME          |
| Motor type                                       | K40214 MO 1425 |
| Nominal output                                   | 130 W          |
| Motor capacitor, capacity:                       | 11 µF          |
| Nominal voltage                                  | 230 V          |
| Nominal frequency                                | 50 Hz          |
| Winding resistance at room temperature X2. 2 -4  | 25,4–29,2 ohm  |
| Winding resistance at room temperature X2. 2 - 3 | 25,1–28,9 ohm  |
| Speed without load                               | 2850 r.p.m.    |
| Rated input when appliance empty                 | 140 W          |
| Current input when appliance empty               | 0,5 A          |



**16. Capacitor motor**

The motor drives the drum and the fan.\_

Specifications

|   |                |
|---|----------------|
| Supplier  | Siemens        |
| Motor type                                      | 1BE 5348 – 2BA |
| Nominal output                                  | 150 W          |
| Motor capacitor, capacity:                      | 8 $\mu$ F      |
| Nominal voltage                                 | 230 V          |
| Nominal frequency                               | 50 Hz          |
| Winding resistance at room temperature X2. 2 -4 | 18,8–23 ohm    |
| Winding resistance at room temperature X2. 2 -3 | 19,9–24,4 ohm  |
| Speed without load                              | 2850 r.p.m.    |
| Rated input when appliance empty                | 200 W          |
| Current input when appliance empty              | 0.6 A          |

**17. Heating**

The heater is situated on the rear of the appliance under the heating duct. The heater consists of two heating coils, the safety cut-out and the NTC R2.

|                           | <b>Condensation</b> | <b>Exhaust air</b> |
|---------------------------|---------------------|--------------------|
| <b>Connection</b>         | <b>16 A</b>         | <b>16 A</b>        |
| <b>Nominal voltage</b>    | <b>230 V</b>        | <b>230 V</b>       |
| <b>Heat setting E2:</b>   | <b>500/600W</b>     | <b>1.200 W</b>     |
| <b>Cold resistance E2</b> | <b>99–108 ohm</b>   | <b>59–66 ohm</b>   |
| <b>Heat setting E3:</b>   | <b>1.800 W</b>      | <b>1.800 W</b>     |
| <b>Cold resistance E3</b> | <b>27–31 ohm</b>    | <b>27–31 ohm</b>   |



**III. CONSUMPTION RATES/ENERGY REQUIREMENT/OTHER DATA**

**1. Air condensation consumption rates**

|   | Spin speed in r.p.m.<br>Washing machine or spin<br>dryer (approx. values) | Drying time in<br>minutes (including<br>8 min. cooling-down<br>time) (approx. values) |     | Energy consumption in<br>kWh (approx. values) |     |
|---|---|---|-----|---|-----|
|   |   | 10A   | 16A | 10A   | 16A |
| Cottons/<br>Coloureds<br>4–5 kg<br>Cupboard dry | 1400  | 85  | 65  | 2,6   | 2,6 |
|   | 800   | 120   | 93  | 3,5   | 3,5 |
| Iron dry  | 1400  | 65  | 50  | 2,0   | 2,0 |
|   | 800   | 93  | 71  | 2,8   | 2,8 |
| Easy care<br>2.5 kg<br>Cupboard dry             | 1000  | 50  | 40  | 1,3   | 1,3 |

The indicated consumption values are guide values which have been determined under normal conditions. Fluctuations up to 10% are possible.

Energy efficiency class **C**



**2. Exhaust-air consumption values**

|   | Spin speed in r.p.m.<br>Washing machine or spin<br>dryer (approx. values) | Drying time in<br>minutes (including<br>8 min. cooling-down<br>time) (approx. values) |     | Energy consumption in<br>kWh (approx. values) |     |
|---|---|---|-----|---|-----|
|   |   | 10A   | 16A | 10A   | 16A |
| Cottons/<br>Coloureds<br>4–5 kg<br>Cupboard dry | 1400  | 75  | 55  | 2,4   | 2,4 |
|   | 800   | 105   | 80  | 3,3   | 3,3 |
| Iron dry  | 1400  | 55  | 40  | 1,7   | 1,8 |
|   | 800   | 77  | 58  | 2,4   | 2,5 |
| Easy care<br>2 kg<br>Cupboard dry               | 1000  | 31  | 27  | 0,9   | 1,0 |

The indicated consumption values are guide values which have been determined under normal conditions. Fluctuations up to 10 % are possible.

Low ambient temperatures in the installation location of the vented dryer will result in longer drying times.

Energy efficiency class **C**

**3. Dimensions and weights**

|                                 |   |
|---------------------------------|---|
| Height                          | 85 cm   |
| Width                           | 60 cm   |
| Depth including wall gap        | 58 cm   |
| Height of built-under appliance | 82 cm   |
| Depth when door open            | 101 cm, 106 cm*   |
| Weight                          | 45 kg 51 kg* air condensation<br>40 kg exhaust air  |
| Door hinge                      | on right / can be changed*  |
| Décor panel dimensions*         | h = 58.9 cm, b = 58.5 cm<br>Décor film from 0.3–1.0 mm can be stuck onto<br>the 2.9 mm thick décor panel<br>* only appliances with large door |



### IV. Components and description of function

#### 1. General

The design is based on a fully electronic solution. All control functions are combined on the power and control module. The power and control module contains all the important components, e.g. micro-controller, relays, power supply, etc. It performs complex functions with respect to controlling drying sequences, monitoring the temperature, ascertaining parameters for identifying the selected degree of dryness, and actuating the operating and display section.

**The functions of the electronics module can be divided into the following groups:**

- Reading and evaluating incoming signals (temperatures, washing resistance, option buttons, switches)
- Linking all available information with the aid of the stored programme
- Determining the switch-off point (degree of dryness)
- Fault detection (overheating, condensation, NTCs, filter/cooler)
- Detecting time-outs (drying time > 240 min.)
- Motor, condensation pump, heater control
- Temperature control and monitor

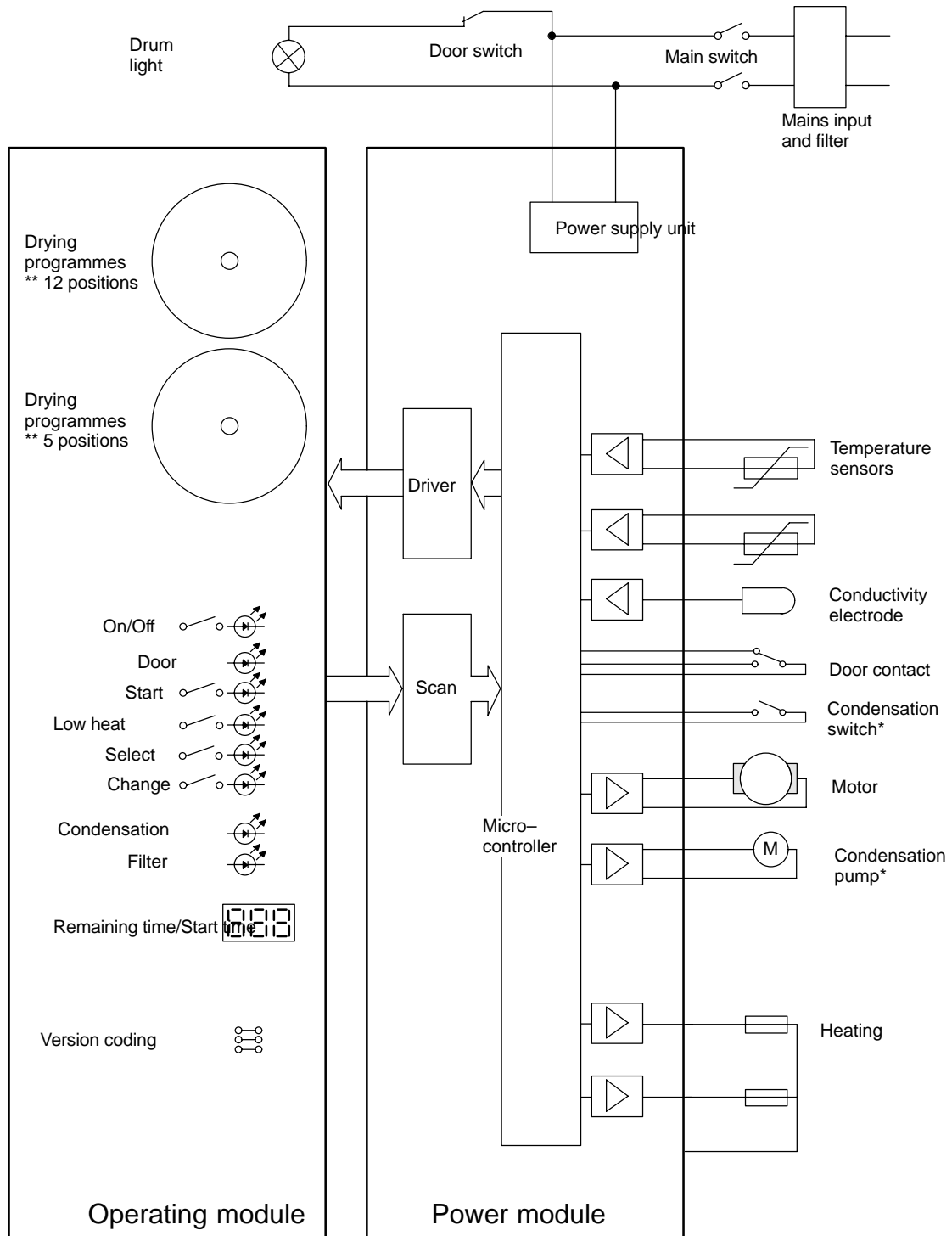

\* air condensation only

\*\* programme and time selection utilises 1 or 2 switches (depending on model)





#### 4. Conductivity measurement

The conductivity measurement of the laundry is based on a voltage measurement of the washing resistance.

The washing resistance is picked up by the metallic surfaces of the two washing agitators which act as electrodes and by the entire inside surface of the drum which acts as a counter-electrode. The washing agitators are actuated with +5 V via the contact strip (insulated from the drum) and the drum slider.

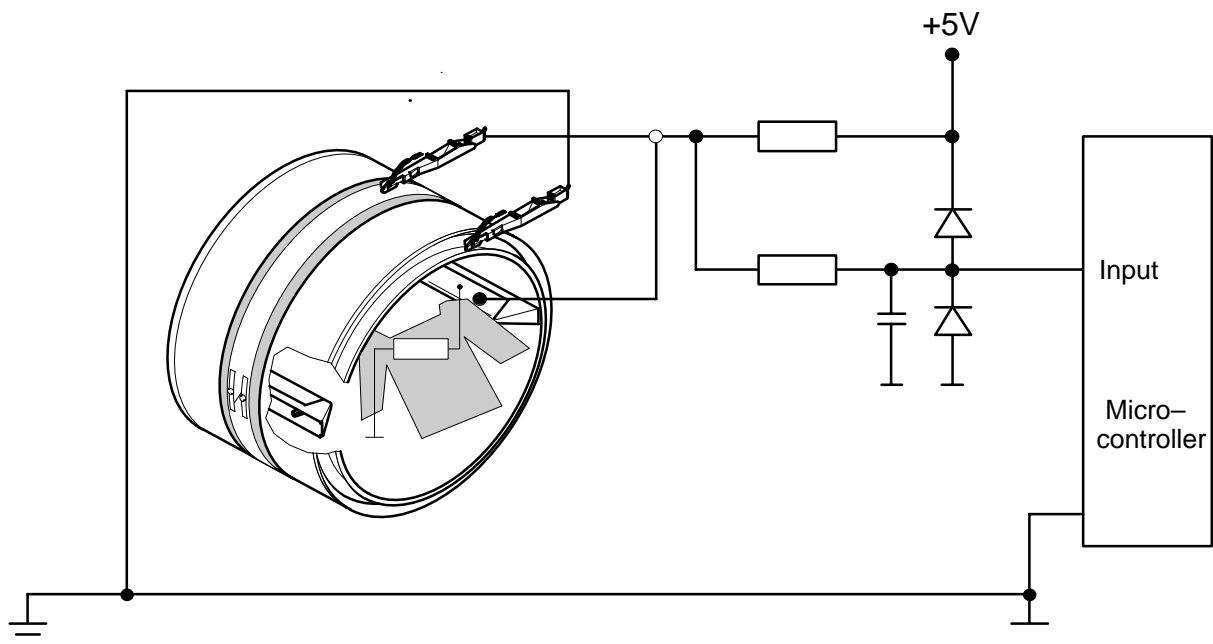

#### 5. Temperature measurement

The temperatures of the heater and the front end shield are converted by the NTCs R2 and R3 to voltages ranging from 0 ... 5 V- and evaluated by the analogue inputs of the micro-controller.

Resistance values on R2 > 110 kohm ( $-14\text{ }^{\circ}\text{C}$ ) are identified as a cable break and values < 16 ohm ( $186\text{ }^{\circ}\text{C}$ ) as a short-circuit. The values 55 kohm and 82 ohm apply to NTC R3.

Short-circuit and cable break in the NTCs or on their connection cables terminate the programme with an error message. The corresponding NTC is indicated by the LED in the operating module (NTC R2 => cupboard dry, NTC R3 => iron dry).

The measured temperature values are required to control the heater and detect overheating.

Overheating is also indicated by the LED (overheating => extra dry) in the operating module.



## 6. Heater actuation

- The two heating elements are actuated via relays.
- If the disconnection temperature is reached on one NTC, the current heating output is reduced until both NTCs detect the minimum temperature.
- On reaching the limiting temperature, all heaters are disconnected. If the temperature does **not** drop below the limiting temperature within 10 x 20 sec., the programme is terminated with the error message "Overheating" (extra dry LED).

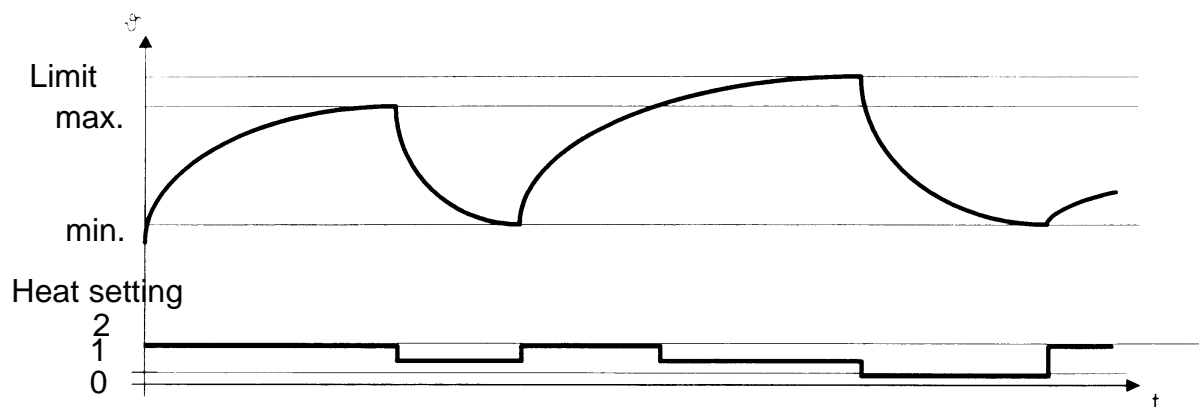

- The safety cut-out on the heater functions independently of the electric controller. If the disconnection temperature is reached, the cut-out is actuated mechanically and can be restarted only by pressing the manual reset (red button).

## 7. Motor actuation

The drum motor is a single-phase capacitor motor. The motor is actuated via two relays (F15 and F16). Relay F15 switches the motor on and off. The direction of rotation is changed by F16 (direction of current reversed in the capacitor) when the motor is switched off.

The motor is protected against thermal overload by a circuit-breaker (winding protector).

## 8. Pump actuation

The pump is actuated via a relay (F14). The pump is clocked and is switched on for 30 seconds and switched off for 90 seconds. If the float switch is closed, the cycle times change. The pump is then switched on for 90 seconds and switched off for 30 seconds.



**V. Repairs**

**1. Troubleshooting – Controller**

When troubleshooting, observe the following:

- All programmes must always be executed.
- The components must be tested according to their electrical specification if "Test component" is indicated in the Procedures column of the troubleshooting table. Before testing, disconnect the plug from the power module.
- Steckverbindungen sollten grundsätzlich auf richtigen Sitz geprüft werden.
- If electronic modules are replaced., the result of the test programmes must be noted on the appropriate sticker.
- When handling electronic modules, the ESD handling regulations must be observed.
- Replaced electronic modules must be put back into the original packaging.

**Troubleshooting plan:**

| Fault no. | Fault description   | Possible cause   | Test / Procedures  |
|-----------|---|--|--|
| 1         | "Iron dry" LED flashes in progress indicator = NTC fault (NTC R3)     | NTC R3, cable or plug-and-socket connection defective.     | Disconnect cable from power module. Check NTC, cable and plug-and-socket connection. |
| 2         | "Cupboard dry" LED flashes in progress indicator = NTC fault (NTC R2) | NTC R2, cable or plug-and-socket connection defective.     | Disconnect cable from power module. Check NTC, cable and plug-and-socket connection. |
| 3         | "Extra dry" LED flashes in progress indicator = overheating           | A<br>Fluff filter or air cooler (capacitor) blocked.       | Clean fluff filter and air cooler (capacitor).                                       |
|           |   | B<br>Air passages for air supply / exhaust air obstructed. | Check air passages.  |
|           |   | C<br>Overload  | Instruction to customer: Load <5 kg dry weight.                                      |
|           |   | D<br>Fan impeller loose.                                   | Check fan impeller.  |
|           |   | E<br>Motor does not rotate.                                | See fault number 6   |
|           |   | F<br>Heater does not switch off.                           | See Fault description 7 B/C  |

## TUMBLE DRYER



| Fault no. | Fault description   | Possible cause   | Test / Procedures   |
|-----------|---|--|---|
| 4         | "End" LED flashes (display only in test programme!) = time fault<br><br>–"Washing is not drying properly"<br>–"Drying time is too long"<br>–"Dries for 240 minutes" | A<br>Washing too wet, original moisture too high.                    | Instruction to customer   |
|           |   | B<br>Overload, < 5 kg dry weight.                                    | Instruction to customer   |
|           |   | C<br>Fluff filter blocked.   | Clean fluff filter.   |
|           |   | D<br>Air cooler blocked.   | Clean air cooler.   |
|           |   | E<br>T-controller for overheating B9 has actuated.                   | See fault number 13   |
|           |   | F<br>Short-circuit or shunt in conductivity system.                  | See fault number 11 B   |
|           |   | G<br>Heater defective.   | See fault number 7  |
|           |   | H<br>Motor does not rotate.  | See fault number 6  |
|           |   | I<br>Mains voltage too low.  | Measure mains voltage under load.<br>Required voltage 230 V (+10%/–15%) |
| 5         | Drum does not rotate  | A<br>Motor does not rotate.  | See fault number 6  |
|           |   | B<br>Belt loose, slips or defective.<br>Tensioning device defective. | Check belt and tensioning device.                                       |
|           |   | C<br>Drum blocked or overloaded.                                     | Check drum.   |



| Fault no. | Fault description   | Possible cause  | Test / Procedures   |
|-----------|---|---|---|
| 6         | Motor does not rotate.<br>– rotates in one direction only<br>– rotates constantly | A<br>Motor, cable or plug-and-socket connection defective.<br>Motor protector has actuated.<br>Motor capacitor defective. | Check motor, capacitor and wiring.  |
|           |   | B<br>Door switch defective.   | See fault number 14   |
|           |   | C<br>Power module defective.  | Start "BW cupboard dry" test programme and measure motor control voltage.<br><br>Clockwise rotation:<br>Mains voltage between X11-10.5 and X11-10.3;<br><br>Anti-clockwise rotation:<br>Mains voltage between X11-10.5 and X11-10.4<br><br>Warning!!!<br>For this test remove heater plug, as the T-controller for overheating B is actuated immediately without the motor. |
| 7         | Does not heat up.   | A<br>T-controller for overheating B9 has actuated.  | See fault number 13 B   |
|           |   | B<br>Heater defective.  | Check heater and cable.   |
|           |   | C<br>NTCs defective.  | Check NTCs (cold resistance) and wiring.  |
|           |   | D<br>Power electronics module defective.  | Start "BW cupboard dry" test programme.<br>On the power module measure the control voltage (mains voltage) for heaters E1, 2, 3.  |

## TUMBLE DRYER



| Fault no. | Fault description  | Possible cause  | Test / Procedures   |
|-----------|--|---|---|
|           |  | E<br>Contact resistance in slider system too high.  | See fault number 10 E   |
| 8         | Heater on constantly (dryer not started)                                   | A<br>Heater defective.  | Check heater and cable.   |
|           |  | B<br>Power module defective.  | See fault number 7 C  |
| 9         | "Condensation" LED flashes, with acoustic signal = condensation tank full. | A<br>Pump defective.  | Check pump and cable,   |
|           |  | B<br>Condensation level switch defective (B10).   | Check switch and cable.   |
|           |  | C<br>Filter in condensation tray inlet blocked.   | Clean filter.   |
|           |  | D<br>Hose blocked or kinked.  | Check hose.   |
|           |  | E<br>Float on the condensation pump jammed, float has absorbed moisture (reduced buoyancy force). | Check float.<br>Replace float.  |
|           |  | F<br>Power module defective.  | Start "BW cupboard dry" test programme. On the power module measure the control voltage (mains voltage) for pump. |
| 10        | – Washing is not drying properly,<br>– too damp.                           | A<br>Wrong programme selected.  | Customer information: select higher degree of dryness.  |
|           |  | B<br>Condensation tank not emptied.   | Empty condensation tank.  |
|           |  | C<br>Door switch or power module defective.   | See fault number 14 A and 15 B  |



| Fault no. | Fault description   | Possible cause   | Test / Procedures   |
|-----------|---------------------|--|---|
| 10        |                     | D<br>Pump or power module defective.                     | See fault number 9 A and 9 E  |
|           |                     | E<br>Contact resistance in conductivity system too high. | Start "Lightly dry" test programme. Short-circuit agitator and drum.<br>If fault is displayed:<br>Check slider system and inner contact of the agitators for continuity. Zwischen Mitnehmer und Pin 3 des Steckers max. 1kΩ.<br>Max 1 kΩ between the drum and pin 1 of the plug.<br>If resistors are o.k., repeat test programme, with jumper between plug-and-socket connection X11-15.1 and X11-15.3. If no fault is displayed, do <b>not</b> replace power module. |
| 11        | Washing is too dry. | A<br>Wrong programme selected.                           | Customer information:<br>Select lower degree of dryness.  |
|           |                     | B<br>Short-circuit or shunt in conductivity system.      | Start "Lightly dry" test programme. Do <b>not</b> short-circuit between agitator and drum.<br>If fault is displayed:<br>Disconnect plug X11-5 from power module.<br>if the fault is still displayed, replace the power module.<br>If no fault is displayed:<br>Check the slider system.<br>Disconnect plug-and-socket connection X11-5 from the power module and measure the insulation between pin 1 and pin 3 on the plug (< 500 V). Insulation resistance > 20 MΩ. |

## TUMBLE DRYER



| Fault no. | Fault description  | Possible cause  | Test / Procedures   |
|-----------|--|---|---|
| 12        | Appliance dries for only 9–13 minutes.                                 | Empty drum, dry washing.                                  | Customer information:<br>After approx. 9–13 minutes the dryer detects an empty drum or dry washing.   |
| 13        | T-controller for overheating B9 has actuated.                          | A<br>Motor does not rotate.                               | See fault number 6  |
|           |  | B<br>Fan impeller loose.                                  | Check fan impeller.   |
|           |  | C<br>Fluff filter or air cooler (capacitor) blocked.      | Clean fluff filter and air cooler.  |
|           |  | D<br>Heater defective.                                    | Check heater and cable.   |
| 14        | "Start" LED does not switch to steady light, appliance does not start. | Door not closed.  |   |
|           |  | A<br>Door switch F1 and / or locking mechanism defective. | Disconnect plug X11-1 from power module. Check switch, cable, plug and mechanism<br>– locking hook<br>– Bowden cable<br>– door button   |
|           |  | B<br>Power module defective.                              | Disconnect plug from power module, short-circuit pin 7 and 5 on plug-and-socket connection on the power module and start any drying programme.<br>If the appliance starts, the power module is o.k. |





| Fault no. | Fault description  | Possible cause                                    | Test / Procedures   |
|-----------|--|---|---|
| 15        | Appliance does not start   | Operating module defective                        | Activate test mode; if this mode can be activated, the operating module is o.k.<br>Check whether the printed-circuit board has become detached from the operating module.<br>If o.k., continue with fault number 14.  |
| 16        | Button, display or programme selection does not function occasionally. | Operating module or power module defective.       | Start "extra dry" and "very dry" test programmes.   |
| 17        | "Filter" LED flashes, although filter and capacitor are clean.         | A<br>Overheating                                  | See fault number 3  |
|           |  | B<br>NTC R2 or NTC R4 defective.                  | Disconnect cable from power module.<br>Check NTC, cable and plug-and-socket connection.   |
| 18        | Starts by itself after being switched on.                              | Appliance was switched off during a drying cycle. | Customer information:<br>If the appliance switches off and subsequently switches back on again while a drying programme is running, the appliance is starting by itself to terminate the programme which was started. |

## 2. Fascia

### Removing the fascia

- Remove the cover plate
- Remove the multiple connector from the operating module on the control and power module.
- The bottom of the fascia is attached to the fittings support with a plastic pin. In the case of a condenser dryer remove the condensation tray beforehand.
- Using a screwdriver, carefully prise out the fascia from below and lift up.



### 3. Operating module

- See "Removing the fascia"
- Remove TX20 screw
- Disengage selector switch (diagonal)
- Carefully detach module from locking hook (see arrows)

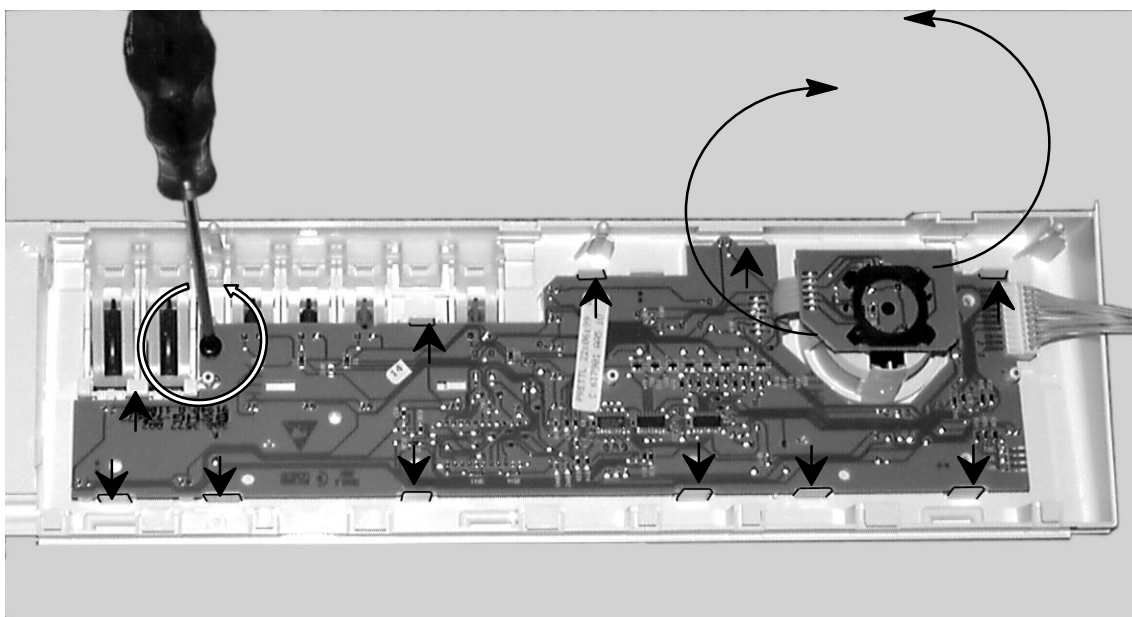

### 4. Capacitor motor

#### Removing the motor

- Remove the cover plate
- Remove the side panel on the right (remove screws on top, at front, at rear – pull off the side panel)
- Remove the heating duct
- Open the maintenance flap, remove the fan impeller for cooling the air
- Loosen the drive belt
- Disconnect the motor
- Remove the motor support
- Mark the installation location of the motor
- Pull the motor out of the back of the appliance

**Warning!!! Warning! When installing the motor, note the marking on the base group and motor.**



### 5. Exhaust-air motor

#### Removing the motor

- Remove the cover plate
- Remove the side panel on the right (remove screws on top, at front, at rear – pull off the side panel)
- Remove the heating duct
- Loosen the drive belt
- Remove the fan impeller for process air
- Remove the motor supports
- Disconnect the motor
- Pull the motor out of the rear bearings

### 6. Condensation pump

#### Removing the condensation pump

- Remove the cover plate
- Remove the side panel on the right (remove screws on top, at front, at rear – pull off the side panel)
- Loosen the drive belt
- Disconnect the motor
- Remove the motor support
- Loosen the condensation hose
- Remove the pump cover and float
- Pull out the pump

**Warning!!! Warning! Ensure that the pump is correctly seated in the base group (locked in position in the base group).**

### 7. Drum bearings at rear

- Remove the cover plate
- Remove the side panels (remove screws on top, at front, at rear – pull off the side panel)
- Remove the heating duct
- Loosen the drum bearings
- Remove the rear panel of the appliance
- Remove 6 bearing mounting bolts from the drum
- Pull the bearings out of the drum interior



Install the bearings as illustrated in the drawing.

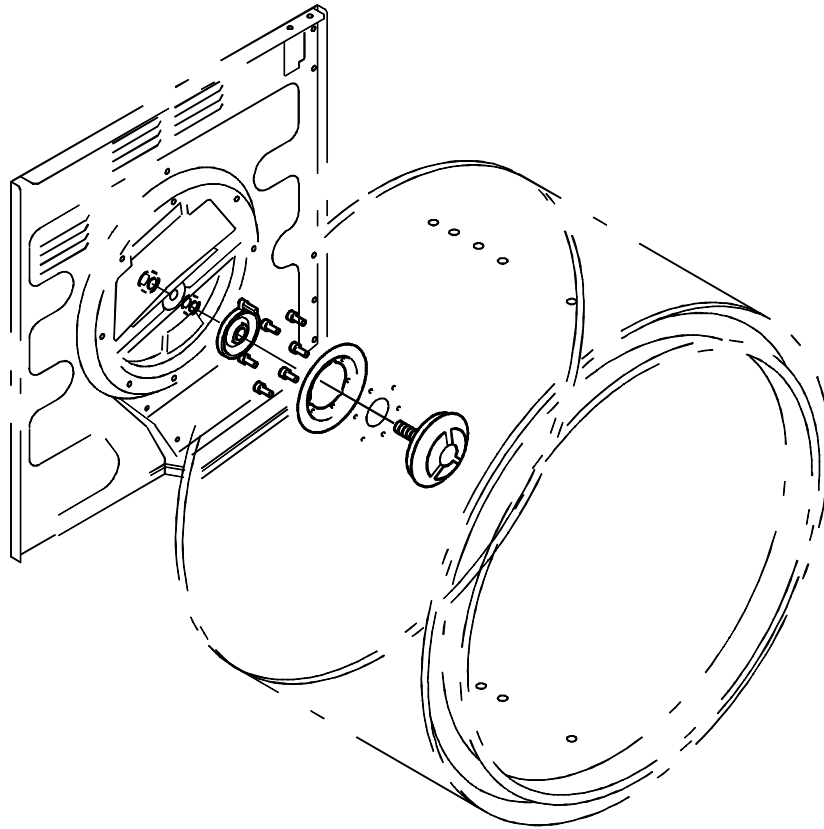



### 8. Drum

#### Removing the drum

- Remove the cover plate
- Remove the side panels (remove screws on top, at front, at rear – pull off the side panel)
- Remove the heating duct
- Loosen the drive belt
- Remove the contact-strip slider and drum earth slider. The drum earth slider must not drop onto the (greased) felt pad. Also risk of breakage.
- Loosen the drum bearings
- Remove the rear panel of the appliance
- Pull the drum out of the back

### 9. Felt pad and slider

#### Removing the felt pad

- See Point 8
- Felt pad, slider, foam support and grease are all available as spare parts. **Only** the enclosed grease (5 g tube) may be used. The felt pad must be lubricated uniformly with the contents of the tube.

### 10. Rear felt pad

#### Removing the rear felt pad

- Remove the cover plate
- Remove the side panels (remove screws on top, at front, at rear – pull off the side panel)
- Remove the heating duct
- Loosen the drum bearings
- Remove the rear panel of the appliance
- Remove the retaining ring for the felt pad from the rear panel of the appliance
- The felt pad is available as a spare part with grease (5 g tube) The felt pad must be lubricated uniformly with **half** the contents of the tube.

### 11. Control and power module

#### Removing the control and power module

- Remove the cover plate
- Remove the side panel on the right (remove screws on top, at front, at rear – pull off the side panel)
- Remove the mounting screw from the right side tie-bar
- Detach the module and holder from the tie-bar



### **VI. Supplements**

#### **1. Self-opening doors on condenser dryers**

When the door is closed, an intermediate state may be generated in the lock – the lock is electrically, but not mechanically, locked.

This intermediate state can only occur if low force is applied when the door is closed in the upper door area.

The door should be closed in the area of the lock hook.

It is not necessary to change any components.

An appropriate note can be found in the operating instructions under "Eliminating minor faults yourself."