

## Adjustable Precision Shunt Regulators

### FEATURES

- Unconditionally Stable.
- Precision Reference Voltage.
  - AIC431 :2.495V  $\pm 0.5\%$
  - TL431A :2.495V  $\pm 1.0\%$
  - TL431 :2.495V  $\pm 1.6\%$
- Sink Current Capability: 200mA.
- Minimum Cathode Current for Regulation: 250 $\mu$ A.
- Equivalent Full-Range Temperature Coefficient: 50 ppm/ $^{\circ}$ C.
- Fast Turn-On Response.
- Low Dynamic Output Impedance: 0.08 $\Omega$ .
- Adjustable Output Voltage.
- Low Output Noise.
- Space Saving SOT-89, SOT-23, TO-92 and SO8 packages.

### DESCRIPTION

The AIC431/TL431A/TL431 are 3-terminal adjustable precision shunt regulators with guaranteed temperature stability over the applicable extended commercial temperature range. The output voltage may be set at any level greater than 2.495V ( $V_{REF}$ ) up to 30V merely by selecting two external resistors that act as a voltage divider network. These devices have a typical output impedance of 0.08 $\Omega$ . Active output circuitry provides a very sharp turn-on characteristics, making these devices excellent improved replacements for zener diodes in many applications.

The precise  $\pm 0.5\%$  reference voltage tolerance of the AIC431 makes it possible in many applications to avoid the use of a variable resistor, consequently saving cost and eliminating drift and reliability problems associated with it.

### TYPICAL APPLICATION CIRCUIT

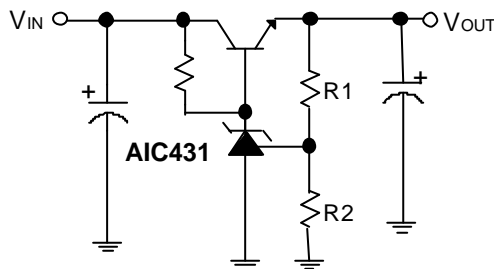

$$V_{OUT} = (1 + R1/R2)V_{REF}$$

**Precision Regulator**

## ORDERING INFORMATION

AIC431 CX  
 TL431A CX  
 TL431 CX

PACKAGING TYPE  
 S: SMALL OUTLINE  
 U: SOT-23  
 X: SOT-89  
 Z: TO-92

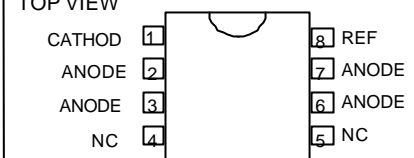
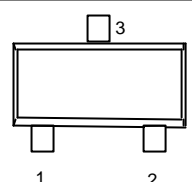
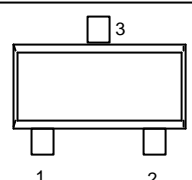
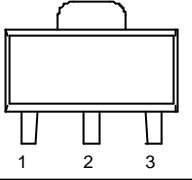
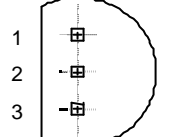
ORDER NUMBER	PIN CONFIGURATION
AIC431CS TL431ACS TL431CS (SO-8)	TOP VIEW 
AIC431CUN TL431ACUN TL431CUN (SOT-23)	FRONT VIEW 1: CATHODE 2: VREF 3: ANODE 
AIC431CUS TL431ACUS TL431CUS (SOT-23)	FRONT VIEW 1: VREF 2: CATHODE 3: ANODE 
AIC431CX TL431ACX TL431CX (SOT-89)	FRONT VIEW 1: VREF 2: ANODE 3: CATHODE 
AIC431CZ TL431ACZ TL431CZ (TO-92)	FRONT VIEW 1: VREF 2: ANODE 3: CATHODE 

## ABSOLUTE MAXIMUM RATINGS

Cathode Voltage .....	30V
Continuous Cathode Current .....	-10mA ~ 250mA
Reference Input Current Range .....	10mA
Operating Temperature Range .....	-40°C ~ 85°C
Lead Temperature .....	260°C
Storage Temperature .....	-65°C ~ 150°C
Power Dissipation ( <b>Notes 1, 2</b> )	
SOT-89 Package .....	0.80W
TO-92 Package .....	0.78W

**Note 1:**  $T_{J, max} = 150^{\circ}C$ .

**Note 2:** Ratings apply to ambient temperature at 25°C.

## TEST CIRCUITS

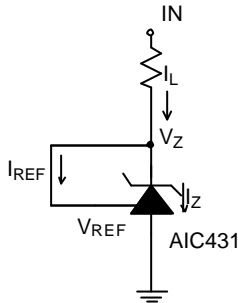
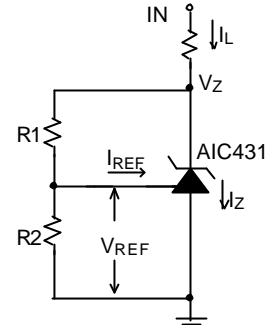

Fig. 1 Test Circuit for  $V_Z=V_{REF}$



Note:  $V_Z=V_{REF}(1+R1/R2)+I_{REF}R1$

Fig. 2 Test circuit for  $V_Z>V_{REF}$

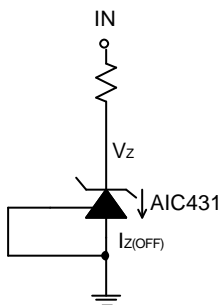

Fig. 3 Test circuit for off-state Current

## ELECTRICAL CHARACTERISTICS (Ta=25°C, unless otherwise specified.)

PARAMETER	TEST CONDITIONS	SYMBOL	MIN.	TYP.	MAX.	UNIT	
Reference Voltage	$V_Z=V_{REF}$ , $I_L=10\text{mA}$ (Fig. 1)	AIC431	2.482	2.495	2.508	V	
		TL431A	2.470	2.495	2.520		
		TL431	2.455	2.495	2.535		
Deviation of Reference Input Voltage Over Temperature (Note 3)	$V_Z=V_{REF}$ , $I_L=10\text{mA}$ , $T_a=0^\circ\text{C}\sim+85^\circ\text{C}$ (Fig. 1)	$V_{DEV}$		9.0	20	mV	
Ratio of the Change in Reference Voltage to the Change in Cathode voltage	$I_Z=10\text{mA}$ (Fig. 2)	$\Delta V_Z=10\text{V}-V_{REF}$	$\frac{\Delta V_{REF}}{\Delta V_Z}$		-0.5	-2.0	mV/V
		$\Delta V_Z=30\text{V}-10\text{V}$			-0.35	-1.5	mV/V
Reference Input Current	$R1=10\text{K}\Omega$ , $R2=\infty$ , $I_L=10\text{mA}$ (Fig. 2)	$I_{REF}$		0.8	3.5	$\mu\text{A}$	

Deviation of Reference Input Current over Temperature	R1 = 10K $\Omega$ , R2 = $\infty$ , I <sub>L</sub> = 10mA T <sub>a</sub> = -20°C ~ +85°C (Fig. 2)	$\alpha I_{REF}$	0.3	1.2	$\mu A$
---	---	------------------	-----	-----	---------

## ELECTRICAL CHARACTERISTICS (Continued)

PARAMETER	TEST CONDITIONS	SYMBOL	MIN.	TYP.	MAX.	UNIT
Minimum Cathode current for Regulation	$V_Z = V_{REF}$ (Fig. 1)	$I_{Z(MIN)}$		0.25	0.5	mA
Off-State Current	$V_Z = 20V, V_{REF} = 0V$ (Fig. 3)	$I_{Z(OFF)}$		0.1	1.0	$\mu A$
Dynamic Output Impedance (Note 4)	$V_Z = V_{REF}$ Frequency = 0Hz (Fig. 1)	$R_Z$		0.08	0.3	$\Omega$

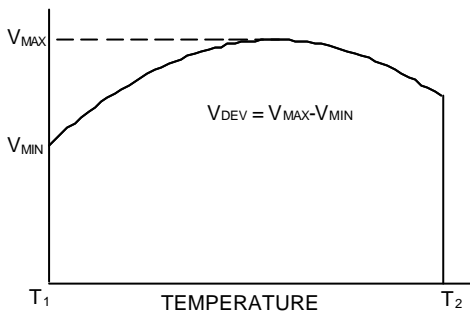

**Note 3.** Deviation of reference input voltage,  $V_{DEV}$ , is defined as the maximum variation of the reference input voltage over the full temperature range.

The average temperature coefficient of the reference input voltage,  $\alpha V_{REF}$  is defined as:

$$\Delta V_{REF} \frac{\text{ppm}}{^\circ\text{C}} = \frac{\pm \left[ \frac{V_{MAX} - V_{MIN}}{V_{REF}(\text{at } 25^\circ\text{C})} \right] 10^6}{T_2 - T_1} = \frac{\pm \left[ \frac{V_{DEV}}{V_{REF}(\text{at } 25^\circ\text{C})} \right] 10^6}{T_2 - T_1}$$

Where:

$T_2 - T_1$  = full temperature change.

$\alpha V_{REF}$  can be positive or negative depending on whether the slope is positive or negative.

Example:  $V_{DEV} = 9.0\text{mV}$ ,  $V_{REF} = 2495\text{mV}$ ,  
 $T_2 - T_1 = 70^\circ\text{C}$ , slope is negative.

$$\alpha V_{REF} = \frac{\left[ \frac{9.0\text{mV}}{2495\text{mV}} \right] 10^6}{70^\circ\text{C}} = -50\text{ppm}/^\circ\text{C}$$

**Note 4.** The dynamic output impedance,  $R_Z$ , is defined as:

$$R_Z = \frac{\Delta V_Z}{\Delta I_Z}$$

When the device is programmed with two external resistors,  $R_1$  and  $R_2$ , (see Fig. 2), the dynamic output impedance of the overall circuit, is defined as:

$$r_z = \frac{\Delta V_Z}{\Delta I_Z} \cong R_Z \left[ 1 + \frac{R_1}{R_2} \right]$$

## TYPICAL PERFORMANCE CHARACTERISTICS

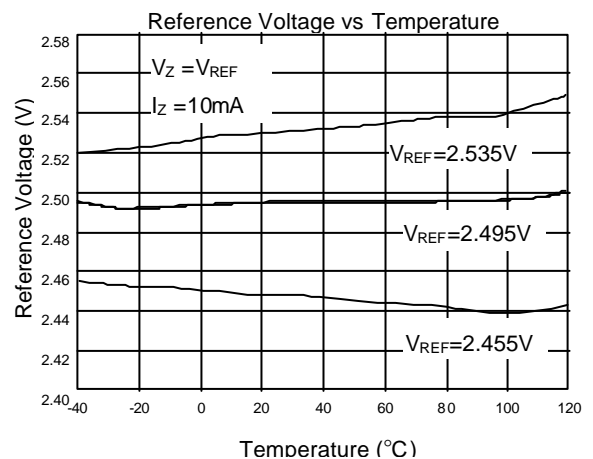
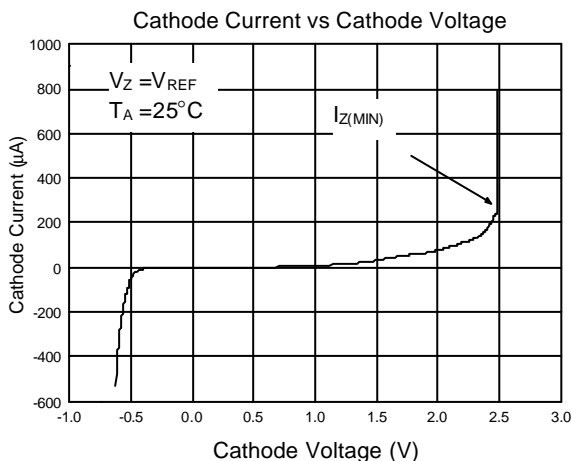

## TYPICAL PERFORMANCE CHARACTERISTICS (Continued)

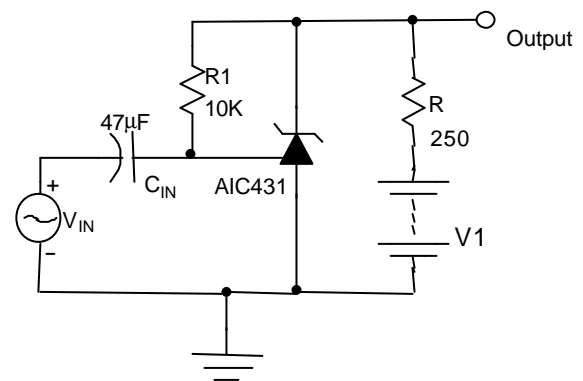
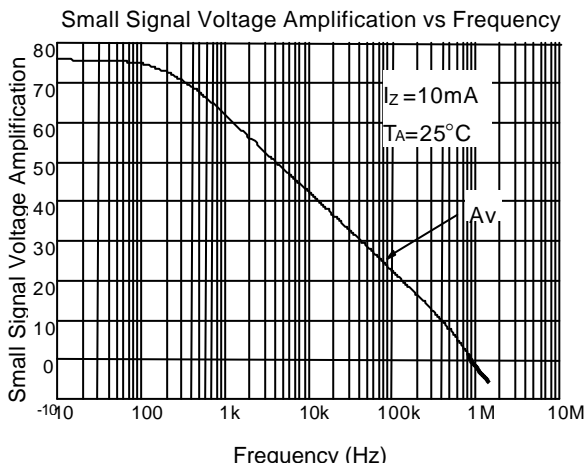
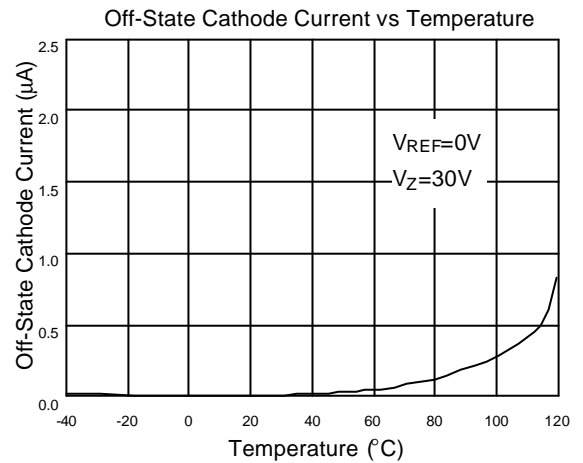
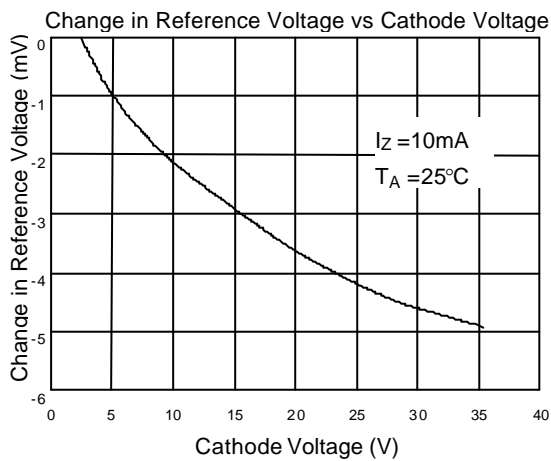
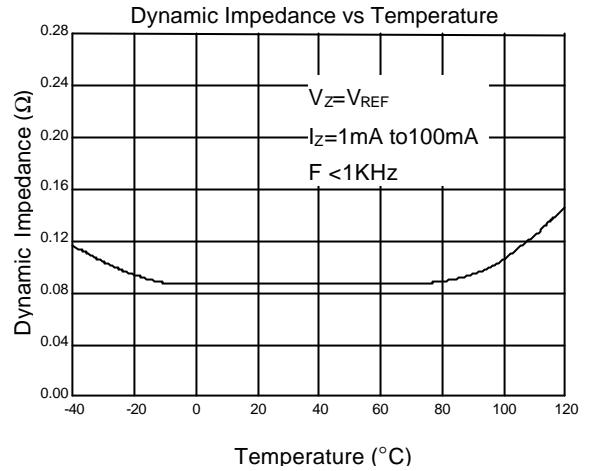
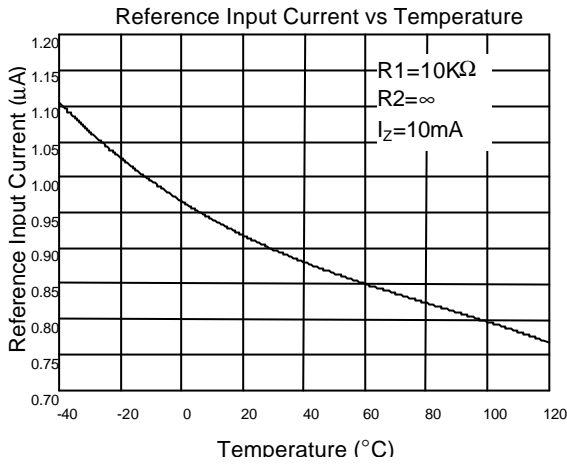

Test Circuit For Frequency Response

## TYPICAL PERFORMANCE CHARACTERISTICS (Continued)

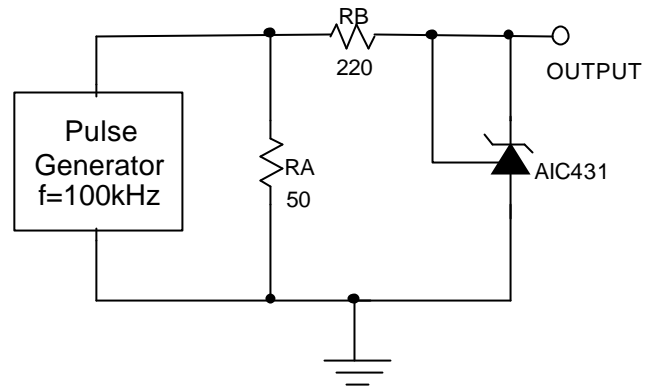
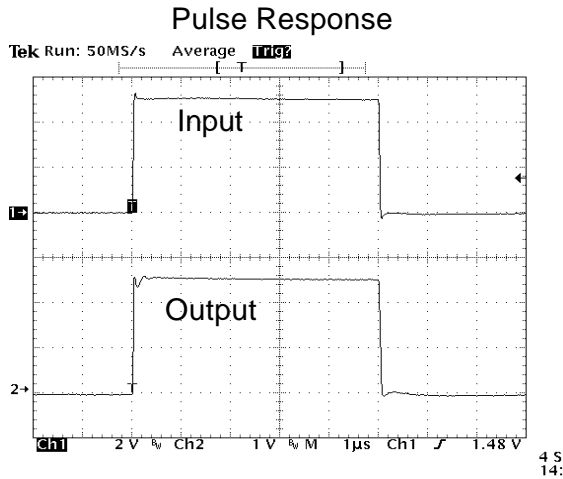

Test Circuit For Pulse Response

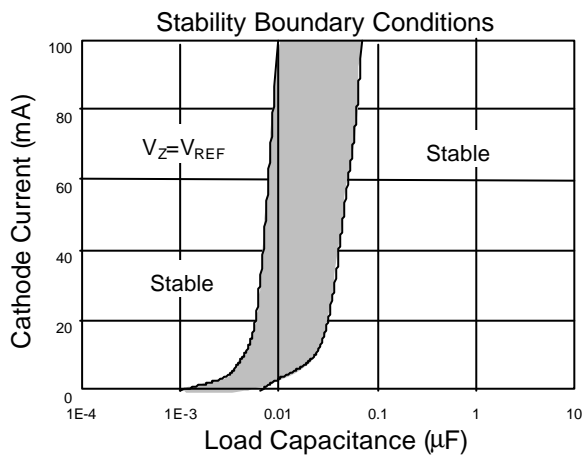

The areas between the curves represent condition that may cause the device oscillate

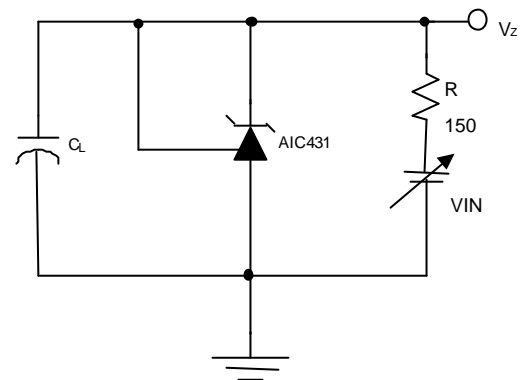

Test Circuit for Stability Boundary Conditions

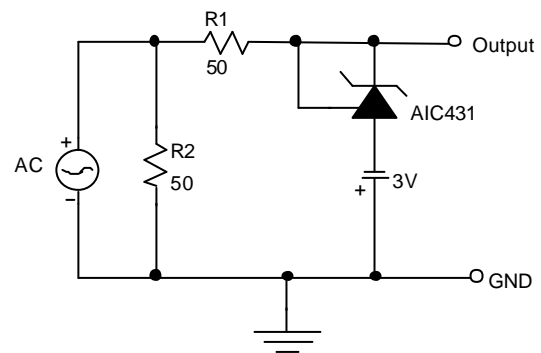
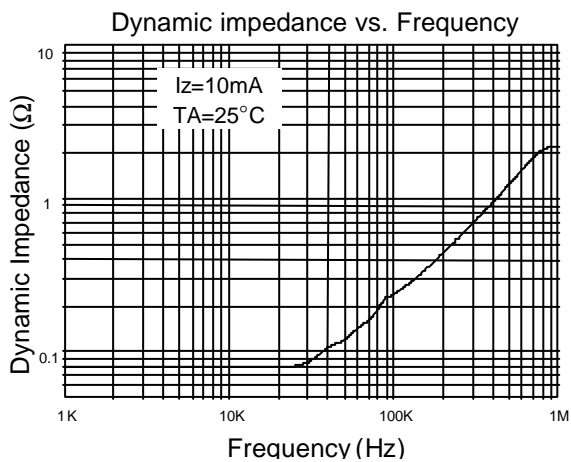

## SYMBOL

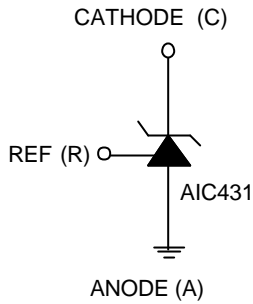

## BLOCK DIAGRAM

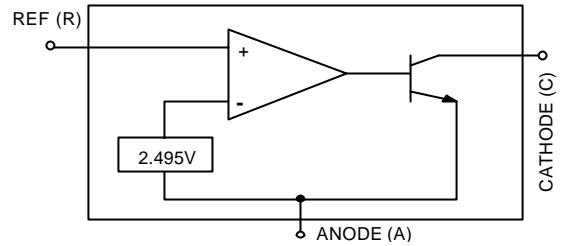

## APPLICATION EXAMPLES

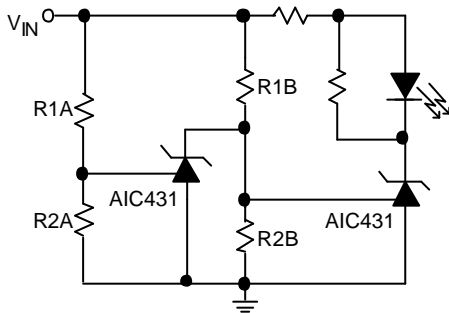

LED on when  $Low\ Limit < V_{IN} < High\ Limit$

$$Low\ Limit \cong V_{REF} (1 + R1B/R2B) \quad Delay = R \times C \times \ln \left( \frac{V_{IN}}{V_{IN} - V_{REF}} \right)$$

$$High\ Limit \cong V_{REF} (1 + R1A/R2A)$$

Fig. 4 Voltage Monitor

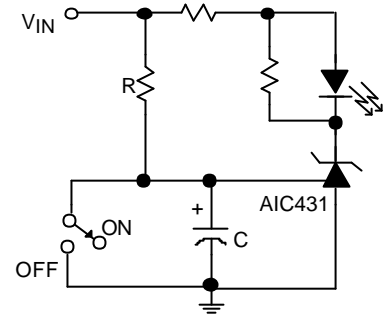
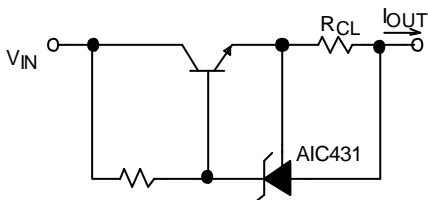
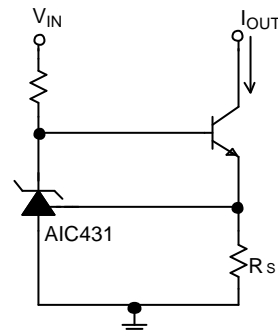

Fig. 5 Delay Timer



$$I_{OUT} = V_{REF} / R_{CL}$$

Fig. 6 Current Limiter or Current Source



$$I_{OUT} = V_{REF} / R_s$$

Fig. 7 Constant-Current Sink



## APPLICATION EXAMPLES (Continued)

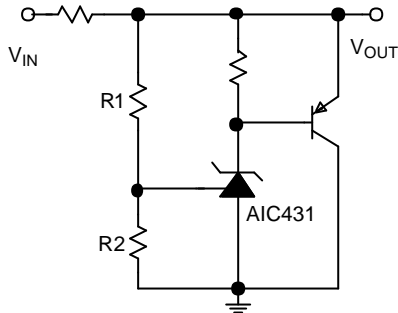

$$V_{OUT} \cong (1 + R1/R2) \times V_{REF}$$

**Fig 8. Higher-Current Shunt Regulator**

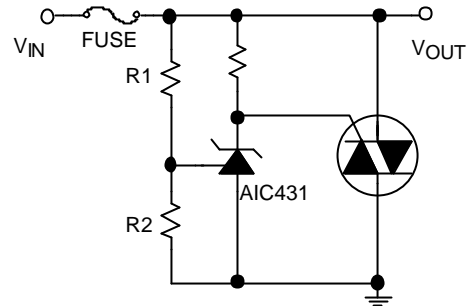

$$V_{LIMIT} \cong (1 + R1/R2) \times V_{REF}$$

**Fig 9. Crow Bar**

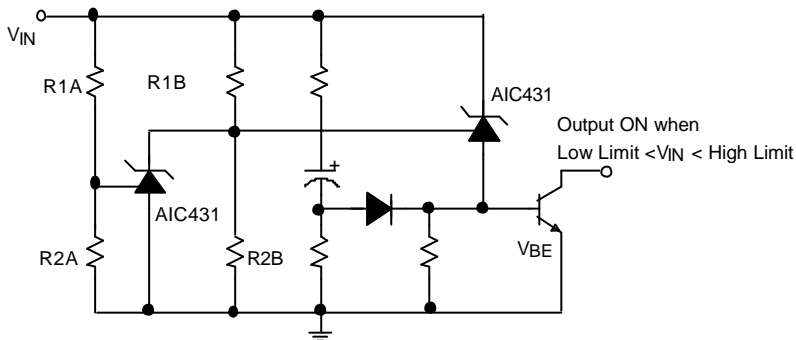

$$\text{Low Limit} \cong V_{REF} (1 + R1B/R2B) + V_{BE}$$

$$\text{High Limit} \cong V_{REF} (1 + R1A/R2A)$$

**Fig 10. Over-Voltage/Under-Voltage Protection Circuit**

## PHYSICAL DIMENSIONS

### 8 LEAD PLASTIC SO (unit: mm)

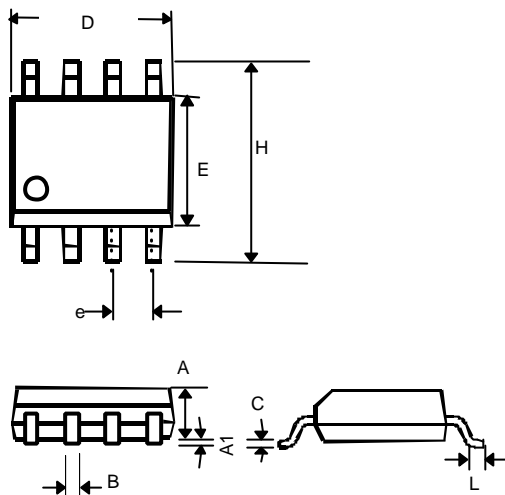

SYMBOL	MIN	MAX
A	1.35	1.75
A1	0.10	0.25
B	0.33	0.51
C	0.19	0.25
D	4.80	5.00
E	3.80	4.00
e	1.27(TYP)	
H	5.80	6.20
L	0.40	1.27

### SOT-23 (unit: mm)

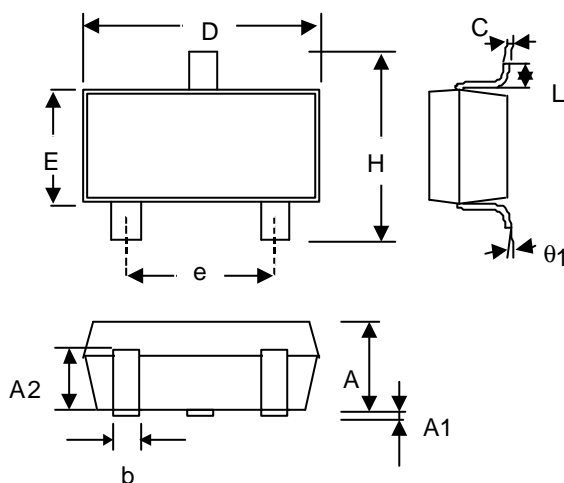

SYMBOL	MIN	MAX
A	1.00	1.30
A1	—	0.10
A2	0.70	0.90
b	0.35	0.50
C	0.10	0.25
D	2.70	3.10
E	1.40	1.80
e	1.90 (TYP)	
H	2.60	3.00
L	0.37	—
1	1°	9°

### SOT-23 MARKING

Part No.	Marking
AIC431CUN	AC1N
TL431CUN	AC2N
TL431ACUN	AC3N

Part No.	Marking
AIC431CUS	AC1S
TL431CUS	AC2S
TL431ACUS	AC3S

## PHYSICAL DIMENSIONS (Continued)

### SOT-89 (unit: mm)

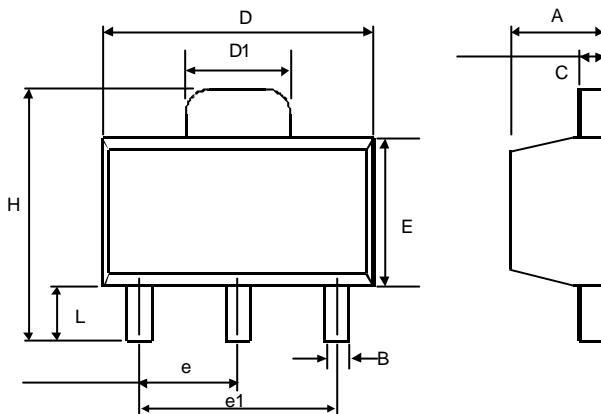

SYMBOL	MIN	MAX
A	1.40	1.60
B	0.36	0.48
C	0.35	0.44
D	4.40	4.60
D1	1.62	1.83
E	2.29	2.60
e	1.50 (TYP.)	
e1	3.00 (TYP.)	
H	3.94	4.25
L	0.89	1.20

### SOT-89 MARKING

Part No.	Marking
AIC431CX	AC01B
TL431CX	AC02B
TL431ACX	AC03B

### TO-92 (unit: mm)

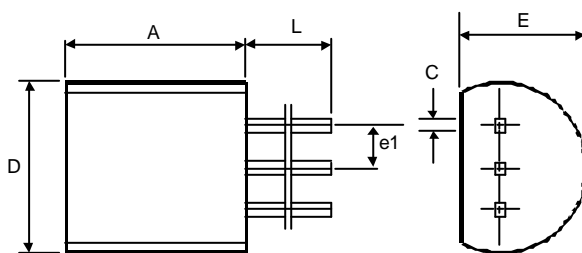

SYMBOL	MIN	MAX
A	4.32	5.33
C	0.38 (TYP.)	
D	4.40	5.20
E	3.17	4.20
e1	1.27 (TYP.)	
L	12.7	-