

# AT818

## 3.0A Ultra Low Dropout Regulator



Immense Advance Tech.

### FEATURES

- Adjustable Output from 0.8V
- Input Voltage as Low as 1.8V
- Enable Pin
- 250mV Dropout @2A
- Over Current and Over Temperature Protection
- 5 $\mu$ A Quiescent Current in Shutdown
- P-CH Design to Reduce the Operation Current
- Full Industrial Temperature Range

### APPLICATION

- Notebook computers
- Battery Powered Systems
- Motherboards/Peripheral Cards
- Telecom/Networking Cards
- Industrial Applications
- Set Top Boxes
- Wireless Infrastructure
- Medical Equipment

### DESCRIPTION

The AT818 is a high performance positive voltage regulator designed for use in applications requiring very low input voltage and very low dropout voltage at up to 3A amps. It operates with a  $V_{IN}$  as low as 1.8V, with output voltage programmable as low as 0.8V. The AT818 features ultra low dropout, ideal for applications where  $V_{OUT}$  is very close to  $V_{IN}$ . Additionally, the AT818 has an enable pin to further reduce power dissipation while shut down. The enable pin may be tied to  $V_{IN}$  if it is not required for ON/OFF control. The AT818 provides excellent regulation over variations in line, load and temperature.

The AT818 is available in the PSOP-8 (Exposed Die Pad) package. The output can be programmed from 0.8V to 5V with two external resistive divider.

The optimum thermal condition has to consider the layout, placement and application to achieve it to satisfy high output current requirement.

### ORDER INFORMATION

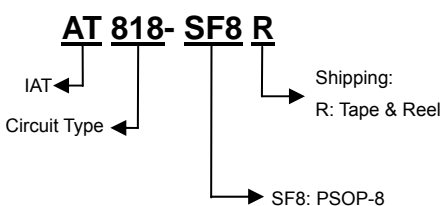

### PIN CONFIGURATIONS (TOP VIEW)

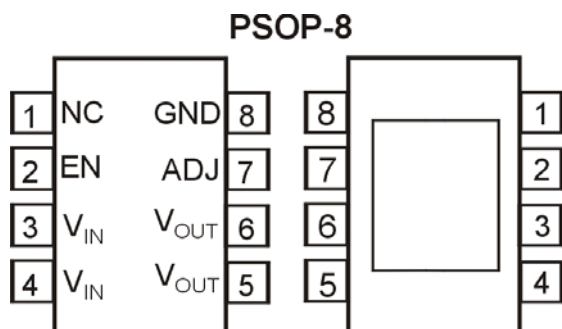

(BOTTOM VIEW)

# AT818

3.0A Ultra Low Dropout Regulator



Immense Advance Tech.

## PIN DESCRIPTIONS

Pin Name	Pin Description
NC	No Connect.
EN	Enable Input. Pulling this pin below 0.4V turns the regulator off, reducing the quiescent current to a fraction of its operating value. The device will be enabled if this pin is left open. Connect to $V_{IN}$ if not being used.
$V_{IN}$	Input Voltage. A large bulk capacitance should be placed closely to this pin to ensure that the input supply does not sag below 1.8V.
$V_{OUT}$	The pin is the power output of the device.
ADJ	ADJ pin is the input to the error amplifier. The ADJ reference voltage is 0.8V referenced to ground. The output range is 0.8V to 5V: $V_{OUT} = \frac{0.8(R1+R2)}{R2}$ Volts
GND	Reference Ground.
THERMAL PAD	Pad for heatsinking purposes. Connect to ground plane using multiple vias. Not electrically connected internally.

## TYPICAL APPLICATION CIRCUITS

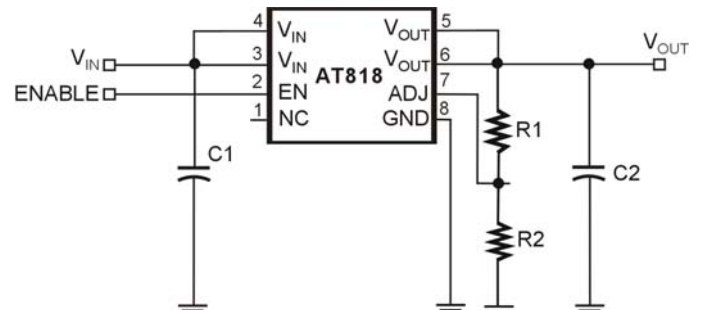
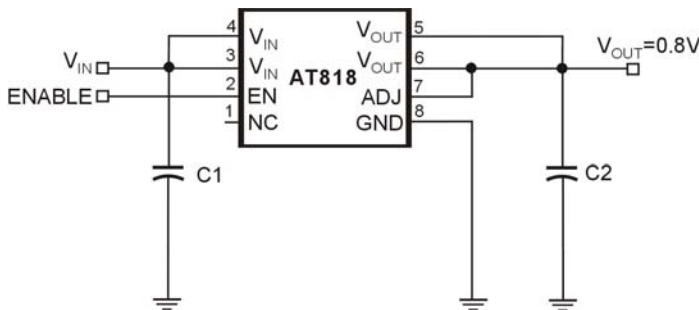

$$V_{OUT} = \frac{0.8(R1+R2)}{R2} \text{ Volts}$$

## BLOCK DIAGRAM

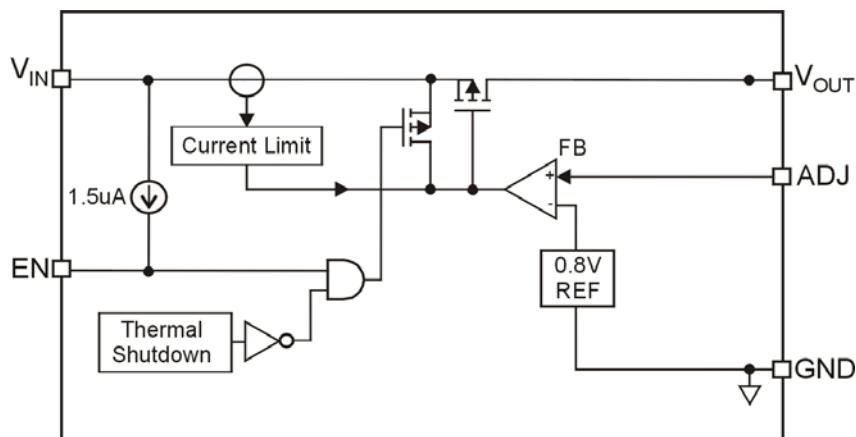

# AT818

## 3.0A Ultra Low Dropout Regulator



Immense Advance Tech.

### ABSOLUTE MAXIMUM RATINGS (Note 1)

Parameter		Symbol	Max Value	Unit
Supply Voltage, $V_{IN}$		$V_{IN}$	6	V
Control Voltage, EN		EN	6	V
Output Voltage, $V_{OUT}$		$V_{OUT}$	6	V
Junction Temperature		$T_J$	125	°C
Lead Temperature(Soldering) 5 Sec.		$T_{LEAD}$	260	°C
Storage Temperature Range		$T_{STG}$	-65 to +150	°C
Power Dissipation $P_D @ T_A=25^{\circ}C$	PSOP-8(Exposed Pad)	$P_D$	2770	mW
Thermal Resistance (Note 2)	PSOP-8	$\Theta_{JA}$	36	°C / W
Thermal Resistance	PSOP-8	$\Theta_{JC}$	5.5	°C / W
ESD Rating (Human Body Model) (Note 3)		$V_{ESD}$	2	kV

### RECOMMENDED OPERATING CONDITIONS (Note 4)

Parameter	Symbol	Operation Conditions	Unit
Supply Voltage, $V_{IN}$	$V_{IN}$	1.8 to 5.5	V
Output Voltage, $V_{OUT}$	$V_{OUT}$	0.8 to 5.5	V
Operating Junction Temperature	$T_J$	-40 to +125	°C
Operating Ambient Temperature Range	$T_A$	-40 to +125	°C

**Note 1:** Stresses listed as the above "Absolute Maximum Ratings" may cause permanent damage to the device. These are for stress ratings. Functional operation of the device at these or any other conditions beyond those indicated in the operational sections of the specifications is not implied. Exposure to absolute maximum rating conditions for extended periods may remain possibility to affect device reliability.

**Note 2:** 2 square inch of FR-4, double sided, 1 oz. minimum copper weight.

**Note 3:** Devices are ESD sensitive. Handling precaution recommended.

**Note 4:** The device is not guaranteed to function outside its operating conditions.

# AT818

## 3.0A Ultra Low Dropout Regulator



Immense Advance Tech.

### ELECTRICAL CHARACTERISTICS

Unless specified:  $V_{EN} = V_{IN}$ ,  $V_{IN} = 1.8V$  to  $5.5V$  and  $I_{LOAD} = 10\mu A$  to  $2A$ ,  $T_A = 25^\circ C$ .

Parameter	Symbol	Test Conditions	Min	Typ	Max	Unit
<b>V<sub>IN</sub></b>						
Supply Voltage Range	$V_{IN}$		1.8		5.5	V
Quiescent Current	$I_Q$	$V_{IN} = 3.3V, V_{EN} = V_{IN}$		0.4	1.45	mA
		$V_{IN} = 5.5V, V_{EN} = 0V$		5	10	$\mu A$
<b>V<sub>OUT</sub></b>						
Reference Voltage (Note 5)	$V_{REF}$	$V_{IN} = 3.3V, V_{ADJ} = V_{OUT}, I_{LOAD} = 10mA$	0.788	0.8	0.812	V
Adjust Pin Current (Note 7)	$I_{ADJ}$	$V_{ADJ} = V_{REF}$		80	200	nA
Line Regulation (Note 5)	$REG_{(LINE)}$	$V_{IN} = 1.8V$ to $5.5V, V_{ADJ} = V_{OUT}, I_{LOAD} = 10mA$		0.2	1.0	%/V
Load Regulation (Note 5)	$REG_{(LOAD)}$	$V_{IN} = 3.3V, V_{OUT} = 2.5V, 10mA \leq I_{LOAD} \leq 2A$		0.1	1.0	%
Dropout Voltage (Note 5, 6)	$V_D$	$I_{LOAD} = 1A, V_{OUT} = 2.5V$		200	300	mV
		$I_{LOAD} = 2A, V_{OUT} = 2.5V$		250	350	mV
		$I_{LOAD} = 3A, V_{OUT} = 2.5V$		350	450	mV
Current Limit (Note 7)	$I_{CL}$			3.6		A
<b>EN</b>						
Enable Pin Current	$I_{EN}$	$V_{EN} = 0V, V_{IN} = 3.3V$		1.5	10	$\mu A$
Enable Pin Threshold	$V_{IH}$	$V_{IN} = 3.3V$	1.6			V
	$V_{IL}$	$V_{IN} = 3.3V$			0.4	V
<b>Oven Temperature Protection</b>						
High Trip Level	$T_{HI}$			160		$^\circ C$
Hysteresis	$V_{HYST}$			20		$^\circ C$

**Note 5:** Low duty cycle pulse testing with Kelvin connections required.

**Note 6:** Defined as the input to output differential at which the output voltage drops to 2%.

**Note 7:** Guaranteed by design.

# AT818

3.0A Ultra Low Dropout Regulator



Immense Advance Tech.

## TYPICAL OPERATING CHARACTERISTICS

(1) Quiescent Current vs. Input Voltage

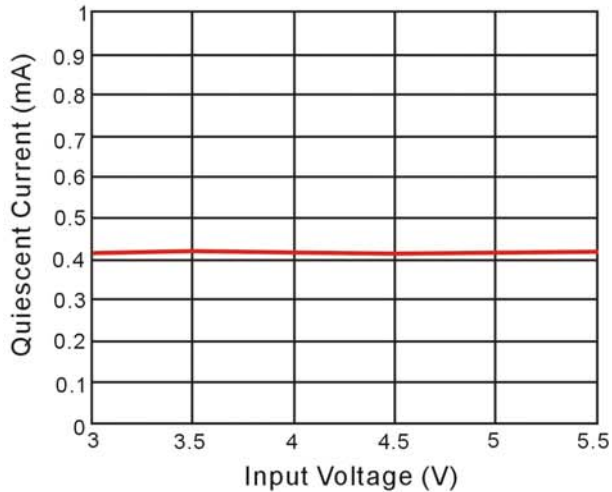

(2) Quiescent Current vs. Temperature

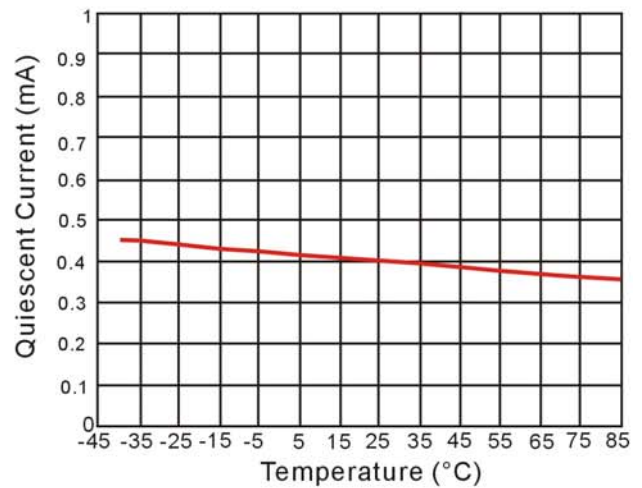

(3) Output Voltage vs. Input Voltage

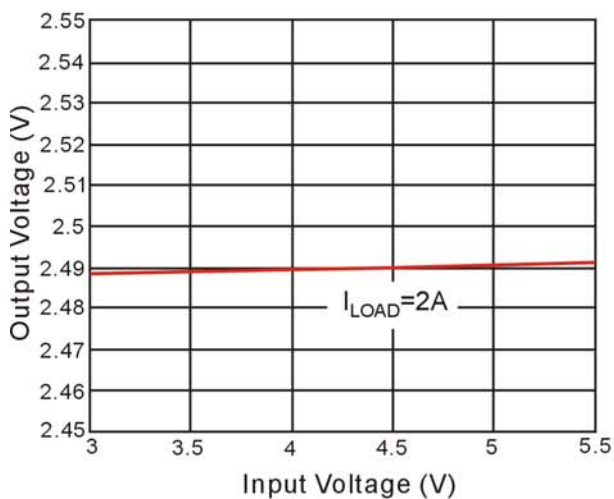

(4) Output Voltage vs. Load Current

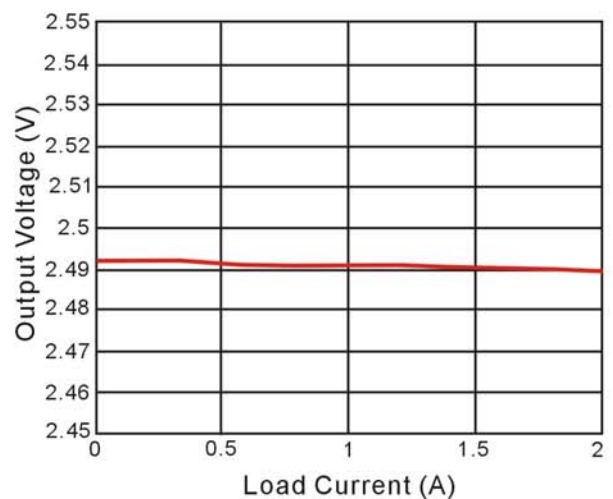

(5) Reference Voltage vs. Input Voltage

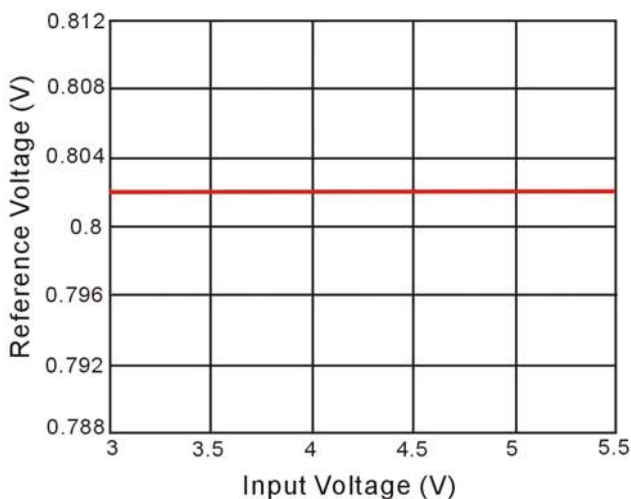

# AT818

## 3.0A Ultra Low Dropout Regulator



Immense Advance Tech.

### APPLICATION INFORMATION

#### Introduction

The AT818 is intended for applications where high current capability and very low dropout voltage are required. It provides a very simple, low cost solution that uses very little PCB real estate. Additional features include an enable pin to allow for a very low power consumption standby mode, and a fully adjustable output.

#### Component Selection

**Input Capacitor:** A minimum of 10 $\mu$ F ceramic capacitor is recommended to be placed directly next to the  $V_{IN}$  pin. This allows for the device being some distance from any bulk capacitance on the rail. Additionally, bulk capacitance of about 100 $\mu$ F may be added closely to the input supply pin of the AT818 to ensure that  $V_{IN}$  does not sag, improves load transient response.

**Output Capacitor:** A minimum bulk capacitance of 10 $\mu$ F, along with a 0.1 $\mu$ F ceramic decoupling capacitor is recommended. Increasing the bulk capacitance will improve the overall transient response. The use of multiple lower value ceramic capacitors in parallel to achieve the desired bulk capacitance will not cause stability issues. Although designed for use with ceramic output capacitors, and thus will also work comfortably with tantalum output capacitors.

**External Voltage Selection Resistors:** The use of 1% resistors, and consider for system stability and power losing, we recommend to design high dividing resistance ( $R1 < 300K\Omega$ ) to strengthen the benefits which AT818 has inherent.

**Noise Immunity:** In very electrically noisy environments, it is recommended that 0.1 $\mu$ F ceramic capacitors be placed from  $V_{IN}$  to GND and  $V_{OUT}$  to GND as close to the device pins as possible.

Parallel a small cap (ex:100pF) would be recommended to improve the transient response.

#### Thermal Considerations

The power dissipation in the AT818 is approximately equal to the product of the output current and the input to output voltage differential:

$$P_D \approx (V_{IN} - V_{OUT}) \times I_{LOAD}$$

The absolute worst-case dissipation is given by:

$$P_{D(MAX)} = (V_{IN(MAX)} - V_{OUT(MIN)}) \times I_{LOAD(MAX)} + V_{IN(MAX)} \times I_G(MAX)$$

For a typical scenario,  $V_{IN} = 3.3V \pm 5\%$ ,  $V_{OUT} = 2.5V$  and  $I_{LOAD} = 1.5A$ , therefore:

$$V_{IN(MAX)} = 3.465V, V_{OUT(MIN)} = 2.45V \text{ and } I_G(MAX) = 1.45mA, \text{ Thus } P_{D(MAX)} = 1.53W.$$

Using this formula, and assuming  $T_{A(MAX)} = 85^\circ C$ , we can calculate the maximum thermal impedance allowable to maintain  $T_J \leq 125^\circ C$

$$R_{TH(J-A)(MAX)} = \frac{(T_{J(MAX)} - T_{A(MAX)})}{P_{D(MAX)}} = \frac{(125 - 85)}{1.53} = 26.1^\circ C/W$$

The package thermal performance may be enhanced by attaching an external heat sink to the thermal pad.

# AT818

3.0A Ultra Low Dropout Regulator



Immense Advance Tech.

## PACKAGE OUTLINE DIMENSIONS

### PSOP-8 PACKAGE OUTLINE DIMENSIONS

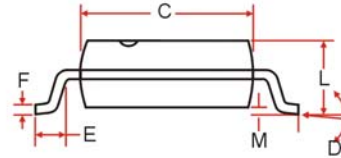
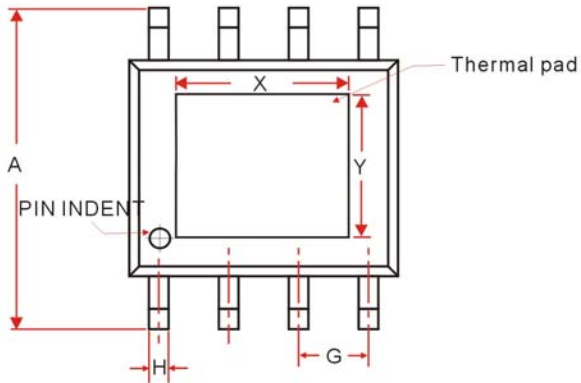

REF.	DIMENSIONS	
	Millimeters	
	Min.	Max.
A	5.79	6.20
B	4.80	5.00
C	3.80	4.00
D	0°	8°
E	0.40	1.27
F	0.15	0.26
M	0	0.25
H	0.31	0.51
L	1.30	1.75
G	1.27 TYP.	
X	3.30 TYP.	
Y	2.50 TYP.	

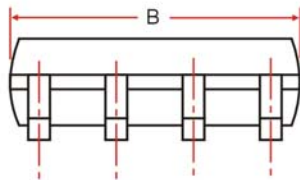

### PSOP-8 PACKAGE FOOTPRINT (mm)

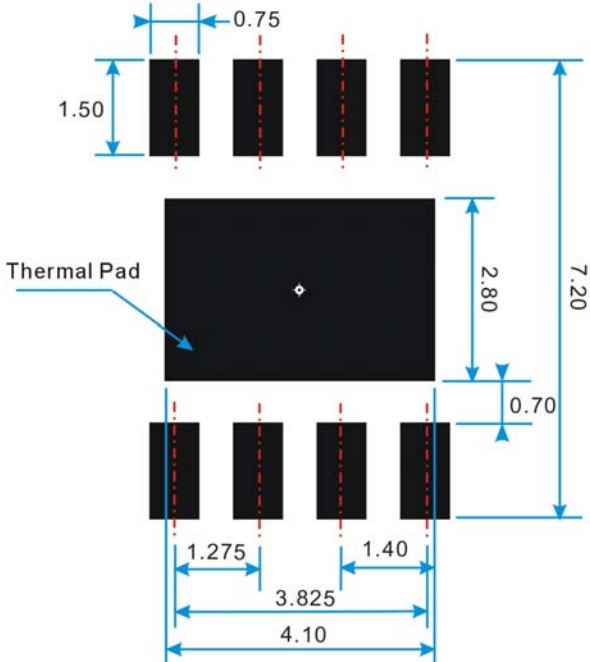

#### Note :

Information provided by IAT is believed to be accurate and reliable. However, we cannot assume responsibility for use of any circuitry other than circuitry entirely embodied in an IAT product; nor for any infringement of patents or other rights of third parties that may result from its use. We reserve the right to change the circuitry and specifications without notice.

Life Support Policy: IAT does not authorize any IAT product for use in life support devices and/or systems. Life support devices or systems are devices or systems which, (I) are intended for surgical implant into the body or (II) support or sustain life, and whose failure to perform, when properly used in accordance with instructions for use provided in the labeling, can be reasonably expected to result in a significant injury to the user. Typical numbers are at 25°C and represent the most likely norm.