

4-3 OLP (OVER LOAD PROTECTOR)

4-3-1 Definition of OLP

- (1) OLP (OVER LOAD PROTECTOR) is attached to Hermetic Compressor and protects Motor by cutting off current in Compressor Motor by Bimetal in the OLP in case of over-rising temperature.
- (2) When over-voltage flows to Compressor motor, Bimetal works by heating the heater inside OLP, and OLP protects Motor by cutting off current which flows to Compressor Motor.

4-3-2 Role of OLP

- (1) OLP is attached to Hermetic Compressor used to Refrigerator and Show Case and prevents Motor Coil from being started in the Compressor.
- (2) Do not turn the Adjust Screw of OLP in any way for normal operation of OLP.
(Composition and connection Diagram of OLP)

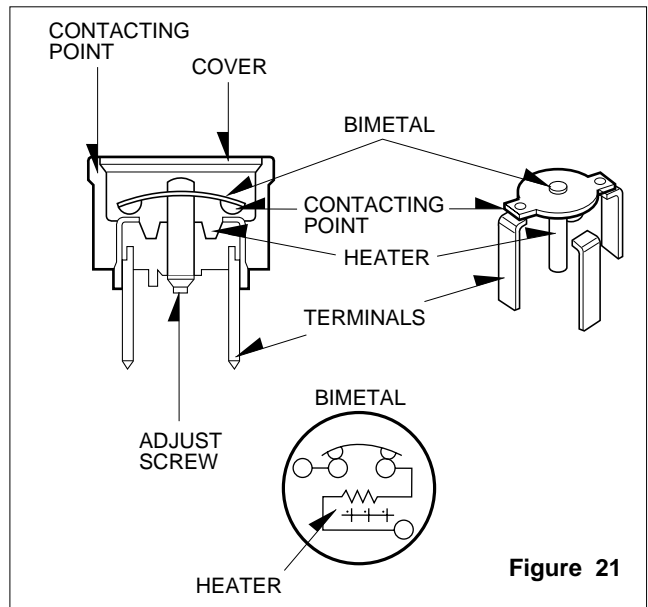
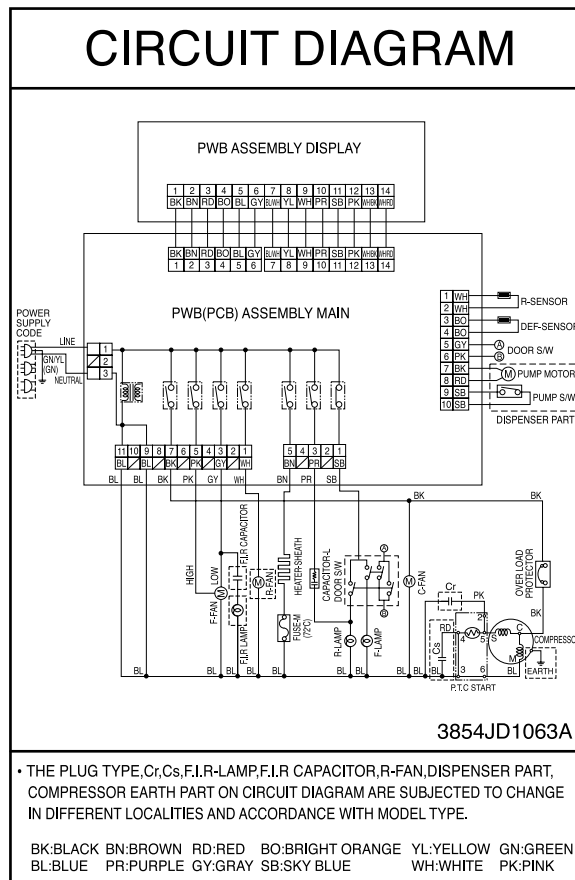

Figure 21

5. CIRCUIT DIAGRAM



NOTE : 1. This is a basic diagram and specifications vary in different localities.