

# ST 400 ST 600



## HIGH PERFORMANCE STEREO AMPLIFIERS

### Features

■ **Rugged steel chassis and a high standard of internal construction ensure long-term durability in "real-world" operation.**

■ **Compact 2U (3.5") height and very efficient forced cooling make for economical and safe racking of high-density multiples.**

■ **Overall sonic quality and stability into long cable runs and difficult loads enhanced by "audiophile-grade" circuit topologies.**

■ **Full headroom, high CMRR balanced inputs on XLR connectors, outputs on 5-way binding posts.**

■ **Product reliability and service life extended through optimum power supply design and improved output stage efficiency.**

■ **In-built protection of amplifier and speaker loads against faults and misuse.**

■ **Ground lift switch fitted to help eliminate system hum loops.**

■ **Large-scale use of common assemblies and components simplifies servicing and minimises spare parts inventory.**

The C-Audio ST Series is comprised of two high performance stereo power amplifiers. The models are:

**ST 400:** 400W/4Ω x 2  
**ST 600:** 600W/4Ω x 2

The ST Series has been developed to provide optimum long-term performance, operational reliability and sonic quality from a tough and compact amplifier package just 2U high. The Power Rating Table (see below) details the continuous average output power of each model into a variety of loads.

### Power Rating Table\*

Continuous Average Power

	Both channels driven			Bridged
	4Ω	8Ω	16Ω	8Ω
<b>ST 400</b>	400	260	130	800
<b>ST 600</b>	600	400	200	1200

\*Output power values are in Watts @ 1kHz and 0.1% distortion

The ST Series design is the result of many years' development and applications expertise being merged with an extensive CAD/CAM resource. All of the advanced technical and operational features built in to these products (see panel) have been well proved, and have been incorporated to satisfy known user requirements.

In particular the benefits of reliability, consistent stability into "difficult" loads and the protection of amplifier and loudspeakers from faults and misuse have been assured through innovative circuit design and the use of high-grade, close tolerance components.

The ST Series products are specified and constructed to be fully performance compatible with all other industry-standard and pro-audio equipment.



POWER AMPLIFIERS

## Technical Specification

ST 600 ST 400

### Inputs

Type	Electronically balanced	
Impedance (Balanced)	20K	
Com. mode Rejection	< -50dB @ 20kHz	
Input Sensitivity	+4dBu	
Gain	32dB	30dB

### Outputs

Impedance @ 1kHz	<32mΩ	
Slew Rate	ST 600	-30V/μsec
	ST 400	-25V/μsec
Rise time	3μsec	
DC-offset	<±50mV	

### Performance

Power bandwidth	10Hz - 50kHz	
Frequency response	2Hz - 125kHz - 3dB	
THD @ rated output (20Hz - 20kHz)	<0.06%	
Hum and noise	-100dB	
Channel separation @ 1kHz	-70dB	
Damping factor @ 1kHz/8Ω	>250	

**Voltage requirements** 220/240V AC±20% 50Hz

### Weight

Nett	15 kg	14 kg
Shipping	19 kg	18 kg

### Dimensions

Width	482 mm
Depth	427 mm
Height	88 mm

### Terminations

Inputs	XLR (female)
Outputs	binding posts
Power	3 Pin IEC connector

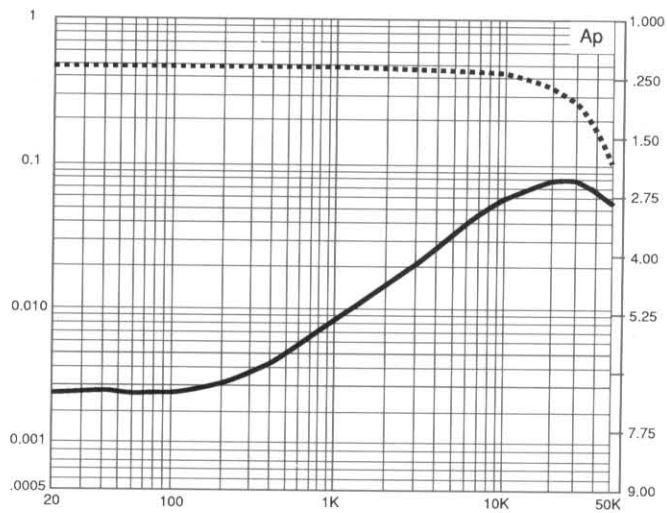

The Above graph shows THD+N and Output level vs. frequency at 550W into 4 Ohm load

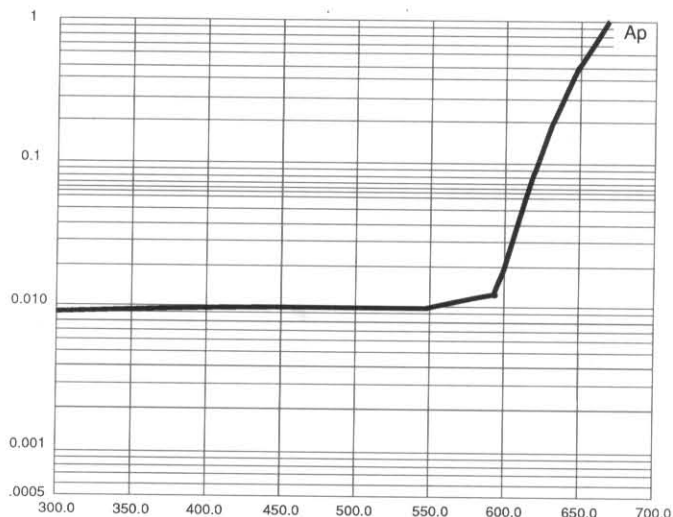

The above graph shows THD+N vs. Output power at 1kHz into 4 Ohm load.

## Architect's and Engineer's specification

The amplifier shall have two channels each capable of producing an output of (Note 1) watts continuous average power into a (Note 1) ohm load with both channels driven. Each input shall be electronically balanced, shall have a CMRR of greater than 50dB at any frequency between 20Hz to 20kHz, and shall incorporate effective filtration against RF and DC. Full output shall be achieved by an input signal of not more than 1.4V RMS per channel. Each channel shall have a +0, -3dB frequency response from 2Hz to 125kHz from 1 watt into 4 ohms to full related power, and shall exhibit distortion of no more than 0.02% at 1kHz into 4 ohms. Hum and noise shall be at least 100dB below full rated output power measured 20Hz to 20kHz with 600 ohm input termination, and channel separation shall be greater than 70dB at 1kHz.

The amplifier shall be stable into any load configuration with any combination of open or grounded input

connection, and shall protect itself and its loudspeaker loads against mismatch, short or open circuits, or any failure which may cause DC offset voltages to appear at its outputs. Muting circuitry shall automatically disconnect loudspeaker loads via relays during power up and power down, and a self-resetting thermal sensing and shutdown system shall be incorporated to protect power transistors against overtemperature operation. A forced cooling fan shall be provided. Each amplifier channel shall have a rotary level control accessible from the front panel and carry a signal clip indicator. LED's shall be provided to indicate the status of AC power and bridged mode. Rear panel mounted switches shall be provided to reconfigure the amplifier from stereo to bridged mode operation, and to safely isolate signal ground from chassis and AC grounds. Audio input shall be via XLR connectors, and output binding posts. The amplifier shall be capable of bridged

mode operation thereby providing up to (Note 1) into (Note 1) ohms and supplying a 70 volt distribution system without output matching transformers. The amplifier shall be capable of operation from a 220/240 volt 50Hz AC power source, and shall be 2 rack units (3.5") high.

The published specification shall be met or exceeded.

The amplifier shall be a model ST (Note 1) manufactured by C-Audio, Cambridge, England.

## Quality assurance programme

This product has been electronically engineered with advanced quality control methods built in. Each unit is tested and aligned against specifications consistent with the highest standards.

Note 1: Insert from Power Rating Table overleaf.

Trade Descriptions Act: C-Audio have a policy of continual product improvement and accordingly reserve the right to change features and specifications without prior notice.



POWER AMPLIFIERS

**C-Audio Limited**  
Barnwell Road Business Park  
Cambridge CB5 8UY, England

Tel: (0223) 211333 Fax: (0223) 410446

# ST1000

HIGH PERFORMANCE  
STEREO AMPLIFIER



The **C-Audio ST1000** Augments C Audio's established ST series providing 1kW of output per channel into 4Ω.

The ST1000 has been developed to provide optimum long-term performance, operational reliability and sonic quality from a tough and compact amplifier package just 3U high. The Power Rating Table (see below) details the continuous average output power of each model into a variety of loads.

## Power Rating Table\*

Continuous Average Power

	Both channels driven			Bridged
	4Ω	8Ω	16Ω	8Ω
<b>ST1000</b>	1000w	680w	340w	2000w

\*Output power values are in Watts @ 1kHz and 0.1% distortion

## Features

■ **Rugged steel chassis and a high standard of internal construction ensure long-term durability in "real-world" operation.**

■ **Compact 3U (5¼") height and very efficient forced cooling make for economical and safe racking of high-density multiples.**

■ **Overall sonic quality and stability into long cable runs and difficult loads enhanced by "audiophile-grade" circuit topologies.**

■ **Full headroom, high CMRR balanced inputs on XLR connectors, outputs on Neutric Speakon connectors.**

■ **Product reliability and service life extended through optimum power supply design and improved output stage efficiency.**

■ **In-built protection of amplifier and speaker loads against faults and misuse.**

■ **Ground lift switch fitted to help eliminate system hum loops.**

■ **Large-scale use of common assemblies and components simplifies servicing and minimises spare parts inventory.**

The ST1000 design is the result of many years' development and applications expertise being merged with an extensive CAD/CAM resource. All of the advanced technical and operational features built in to these products (see panel) have been well proven, and have been incorporated to satisfy known user requirements.

In particular the benefits of reliability, consistent stability into "difficult" loads and the protection of amplifier and loudspeakers from faults and misuse have been assured through innovative circuit design and the use of high-grade, close tolerance components.

The ST1000 is specified and constructed to be fully performance compatible with all other industry-standard and pro-audio equipment.

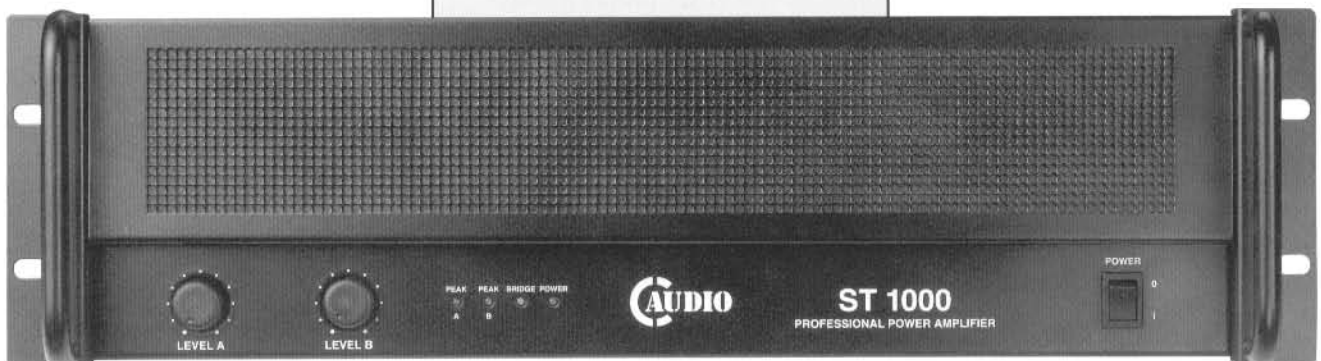

POWER AMPLIFIERS

## Technical Specification

ST 1000

### Inputs

Type	Electronically balanced
Impedance (Balanced)	20K
Com.mode Rejection	<-50dB @ 20kHz
Input Sensitivity	+4dBu
Gain	+34dB

### Outputs

Impedance @ 1kHz	<32m $\Omega$
Slew Rate	35v/ $\mu$ sec
Rise time	3 $\mu$ sec
DC-offset	< $\pm$ 50mV

### Performance

Power bandwidth	10Hz - 50kHz
Frequency response	2Hz - 125kHz - 3dB
THD @ rated output (20Hz - 20kHz)	<0.06%
Hum and noise	-100dB
Channel separation @ 1kHz	-70dB
Damping factor @ 1kHz/8 $\Omega$	>250

**Voltage requirements** 220/240V AC $\pm$ 20% 50Hz

### Weight

Nett	20kg
Shipping	24kg

### Dimensions

Width	482mm
Depth	427mm
Height	132mm

### Terminations

Inputs	XLR (female)
Outputs	Neutric Speakon
Power	3 Pin IEC connector

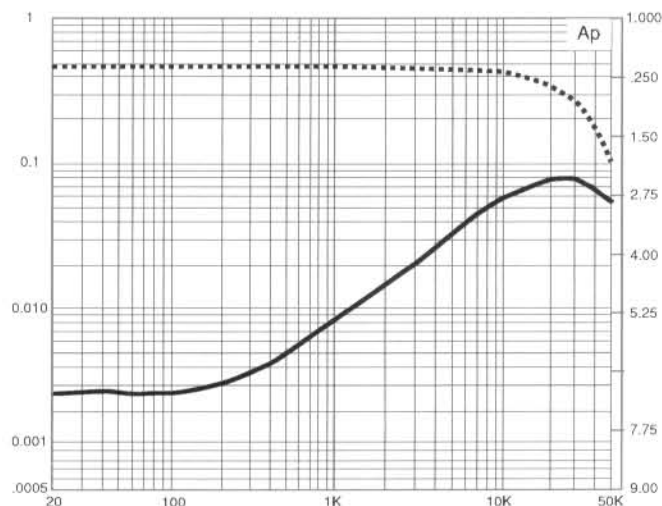

The above graph shows THD+N and Output Level vs. frequency at 500W into 4 Ohm load

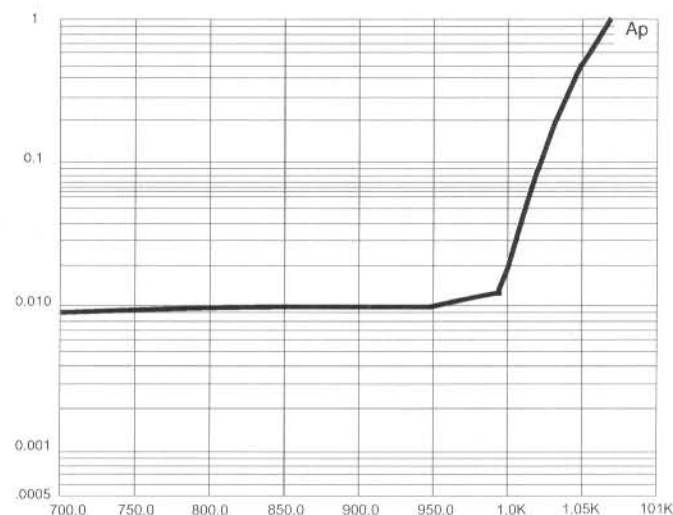

The above graph shows THD+N vs. Output power at 1kHz into 4 Ohm load

## Architect's and Engineer's specification

The amplifier shall have two channels each capable of producing an output of (Note 1) watts continuous average power into a (Note 1) ohm load with both channels driven. Each input shall be electronically balanced, shall have a CMRR of greater than 50dB at any frequency between 20Hz to 20kHz, and shall incorporate effective filtration against RF and DC. Full output shall be achieved by an input signal of not more than 1.4V RMS per channel. Each channel shall have a +0, -3dB frequency response from 2Hz to 125kHz from 1 watt into 4 ohms to full related power, and shall exhibit distortion of no more than 0.02% at 1kHz into 4 ohms. Hum and noise shall be at least 100dB below full rated output power measured 20Hz to 20kHz with 600 ohm input termination, and channel separation shall be greater than 70dB at 1kHz.

The amplifier shall be stable into any load configuration with any combination of open or grounded input connection, and shall protect itself and its loudspeaker loads against mismatch,

short or open circuits, or any failure which may cause DC offset voltages to appear at its outputs. Muting circuitry shall automatically disconnect loudspeaker loads via relays during power up and power down, and a self-resetting thermal sensing and shutdown system shall be incorporated to protect power transistors against overtemperature operation. A forced cooling fan shall be provided. Each amplifier channel shall have a rotary level control accessible from the front panel and carry a signal clip indicator. LED's shall be provided to indicate the status of AC power and bridged mode. Rear panel mounted switches shall be provided to reconfigure the amplifier from stereo to bridged mode operation, and to safely isolate signal ground from chassis and AC grounds. Audio input shall be via XLR connectors, and output via Neutric Speakon connectors. The amplifier shall be capable of bridged mode operation thereby providing up to (Note 1) into (Note 1) ohms and supplying a 70 volt distribution system

without output matching transformers. The amplifier shall be capable of operation from a 220/240 volt 50Hz AC power source, and shall be 3 rack units (5 1/4") high.

The published specification shall be met or exceeded.

The amplifier shall be a model ST1000 manufactured by C-Audio, Cambridge, England.

### Quality assurance programme

This product has been electronically engineered with advanced quality control methods built in. Each unit is tested and aligned against specifications consistent with the highest standards.

Note 1: Insert from Power Rating Table overleaf.

Trade Descriptions Act: C-Audio have a policy of continual product improvement and accordingly reserve the right to change features and specifications without prior notice.



POWER AMPLIFIERS

A division of Harman International Industries Limited

C-Audio

Barnwell Road Business Park  
Cambridge CB8 8UY, England

Tel: (01223) 211333 Fax: (01223) 410446

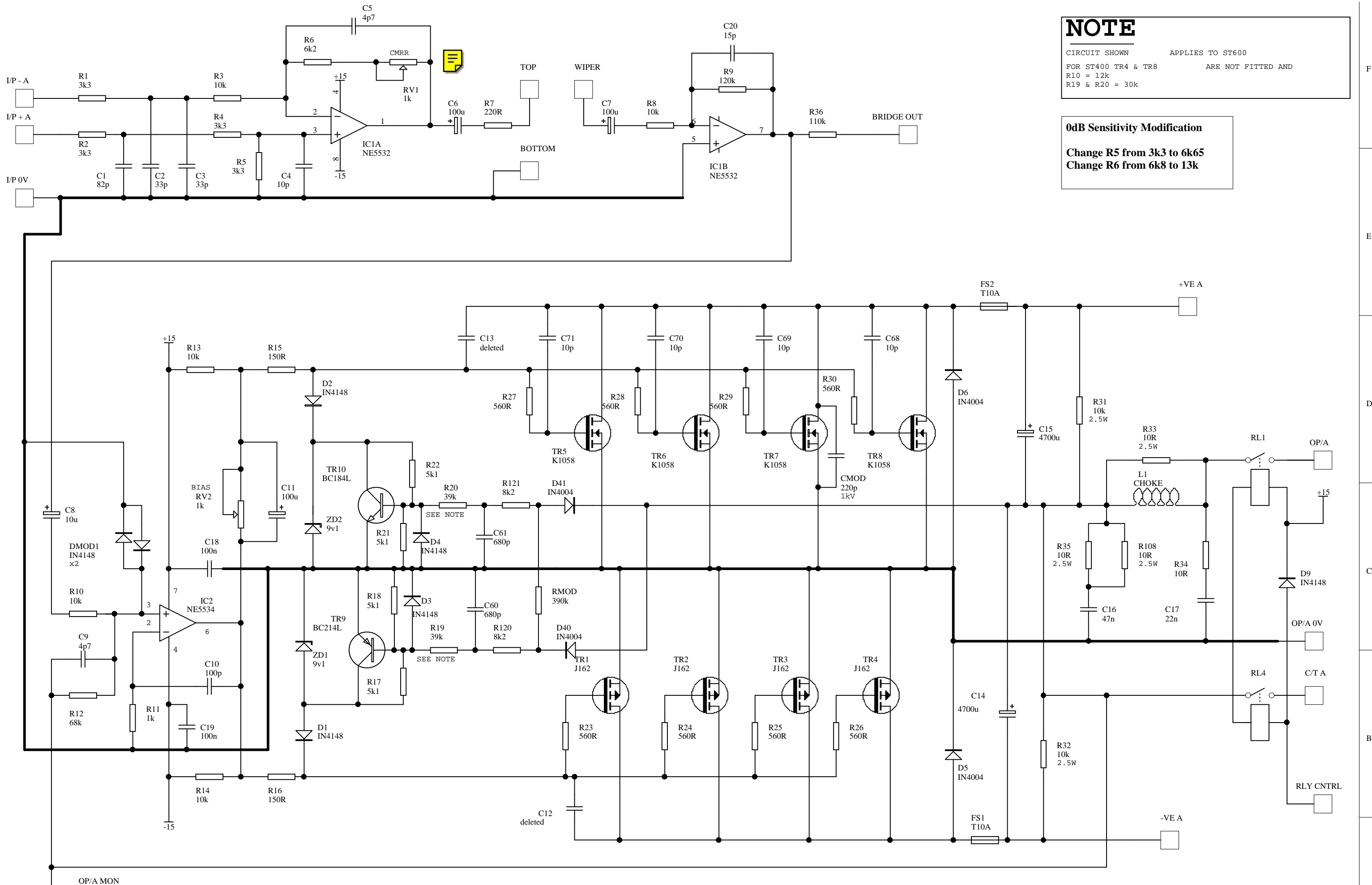

**NOTE**  
 CIRCUIT SHOWN APPLIES TO ST600  
 FOR ST400 TR4 & TR8 ARE NOT FITTED AND  
 R10 = 12k  
 R19 & R20 = 30k

**0dB Sensitivity Modification**  
 Change R5 from 3k3 to 6k65  
 Change R6 from 6k8 to 13k

Title		<b>ST 600/400 PCB</b>	
Size	Number	<b>C1022</b>	
		Revision	<b>3</b>
Date:	1-Jul-1999	Sheet of	3 4
File:	D:\PROTEL\ST\MAINA SCH	Drawn By:	LMB

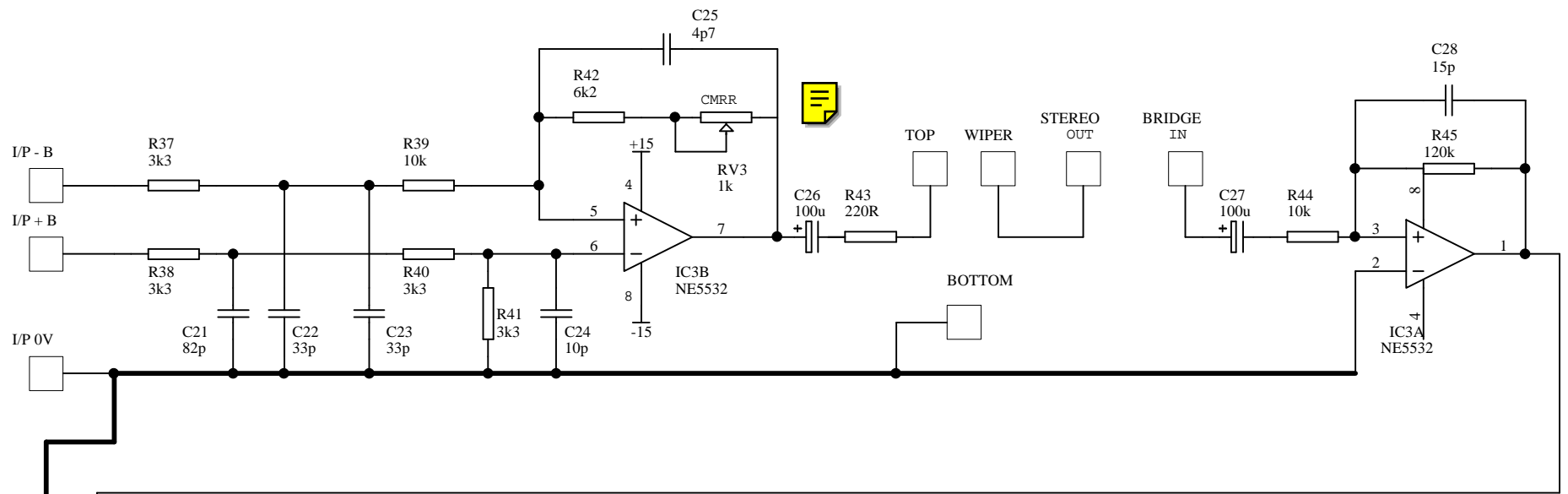

**NOTE**  
 CIRCUIT DIAGRAM SHOWN APPLIES TO ST600  
 FOR ST400 :  
 TR14 & TR18 ARE NOT FITTED  
 R46 = 12k  
 R55 & R56 = 30k

**0dB Sensitivity Modification**  
 Change R41 from 3k3 to 6k65  
 Change R42 from 6k8 to 13k

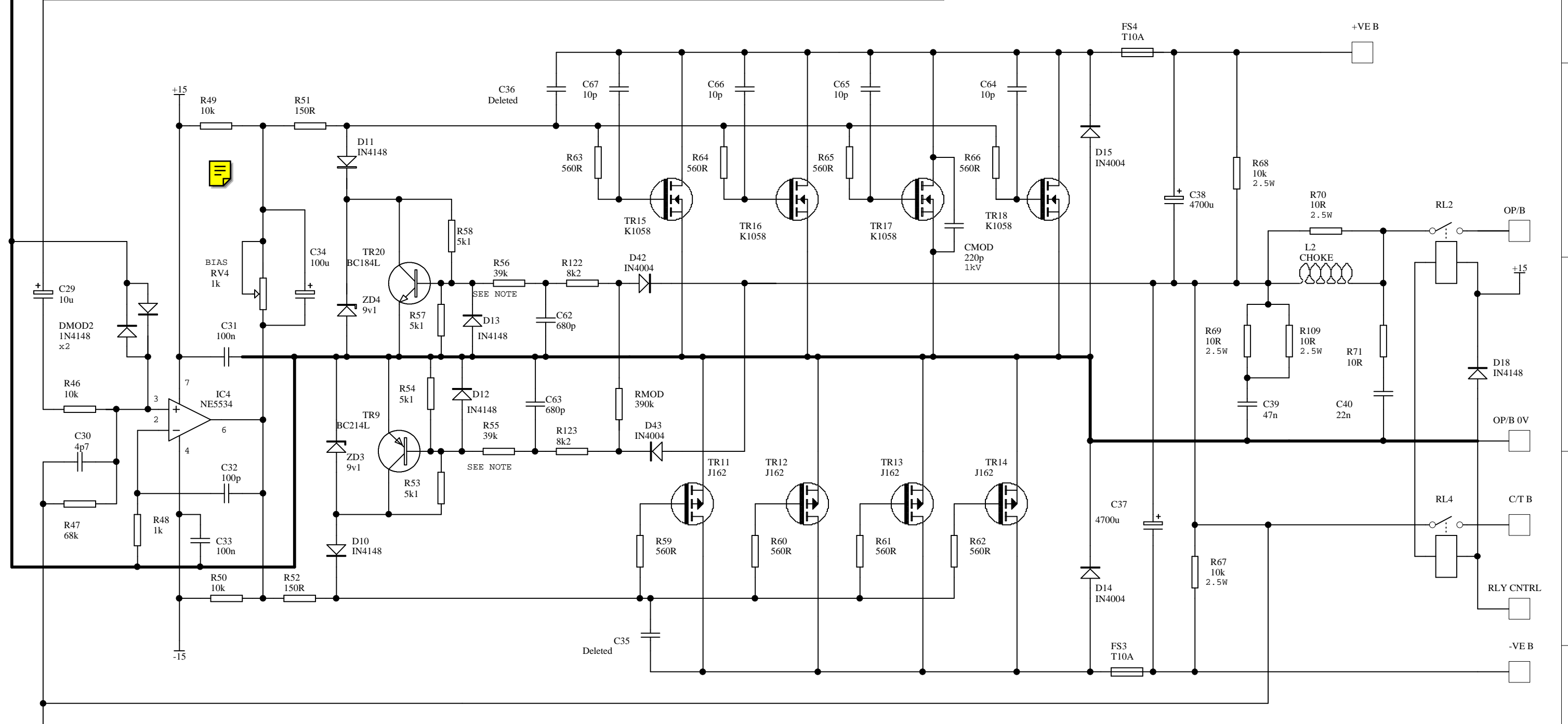

Title		<b>STi 600/400 PCB</b>	
Size	Number	<b>C1022</b>	
	Revision	<b>3</b>	
Date:	1-Jul-1999	Sheet of	2 4
File:	D:\PROTEL\STMAINR SCH	Drawn By:	LMB

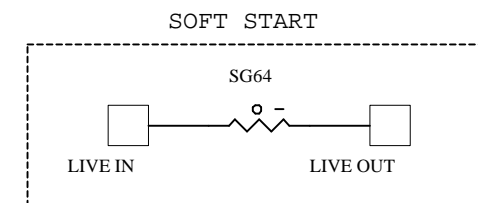
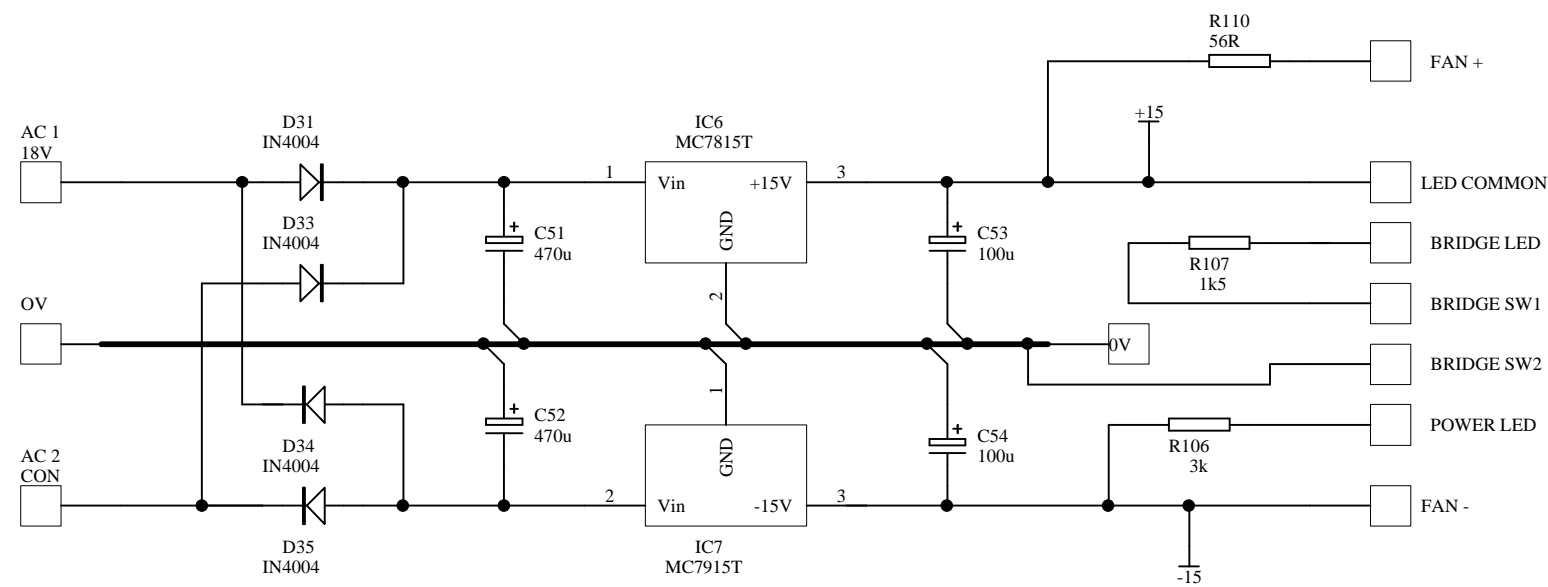
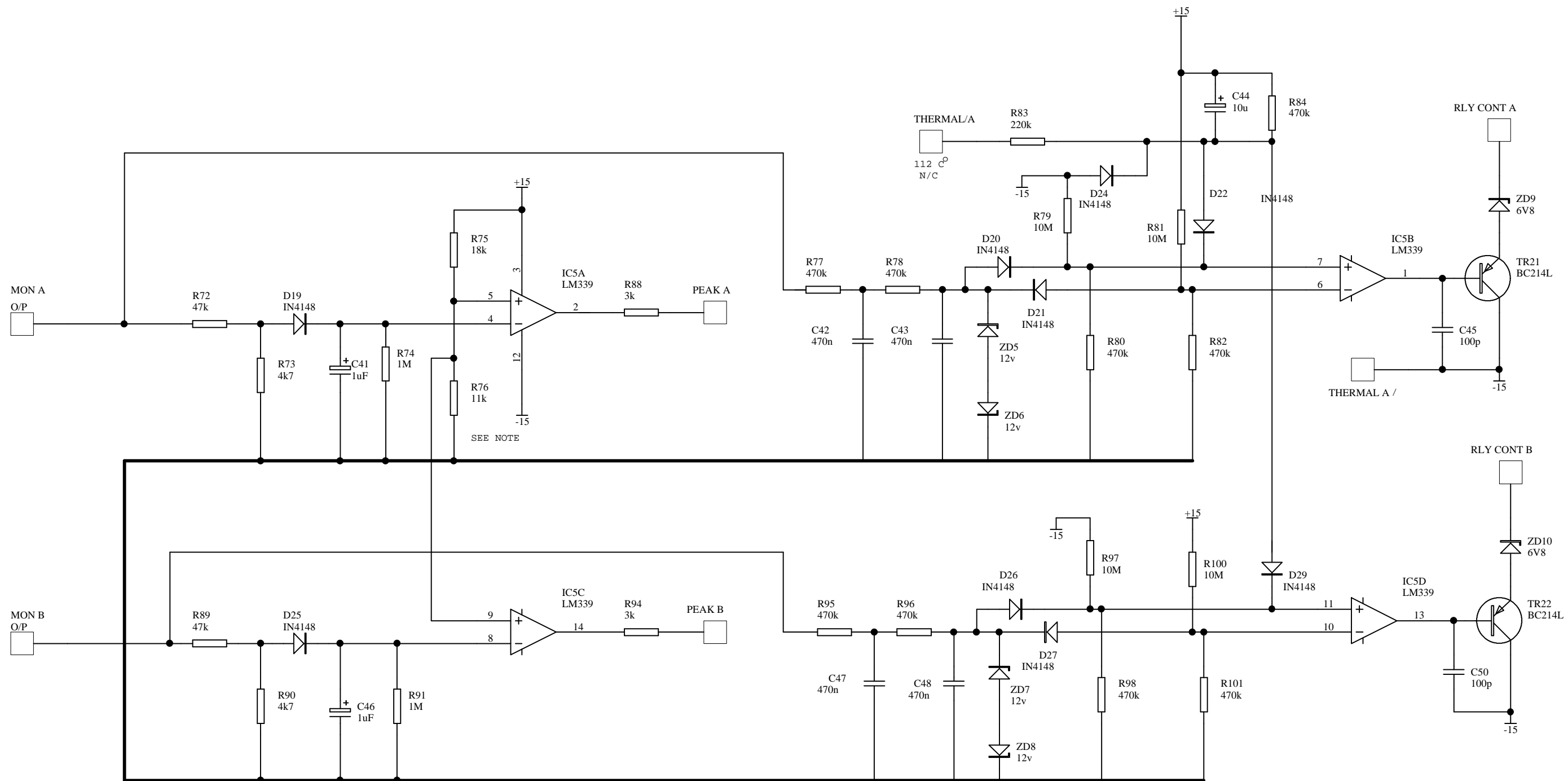

**NOTE:**  
 CIRCUIT SHOWN APPLIES TO THE ST600 VERSION  
 FOR THE ST400 R76 = 7k5

Title		
<b>STi 600 / 400 PCB</b>		
Size	Number	Revision
A3	<b>C1022</b>	3
Date:	1-Jul-1999	Sheet of 1 4
File:	D:\PROTEL\STMAIN1.SCH	Drawn By: LMB

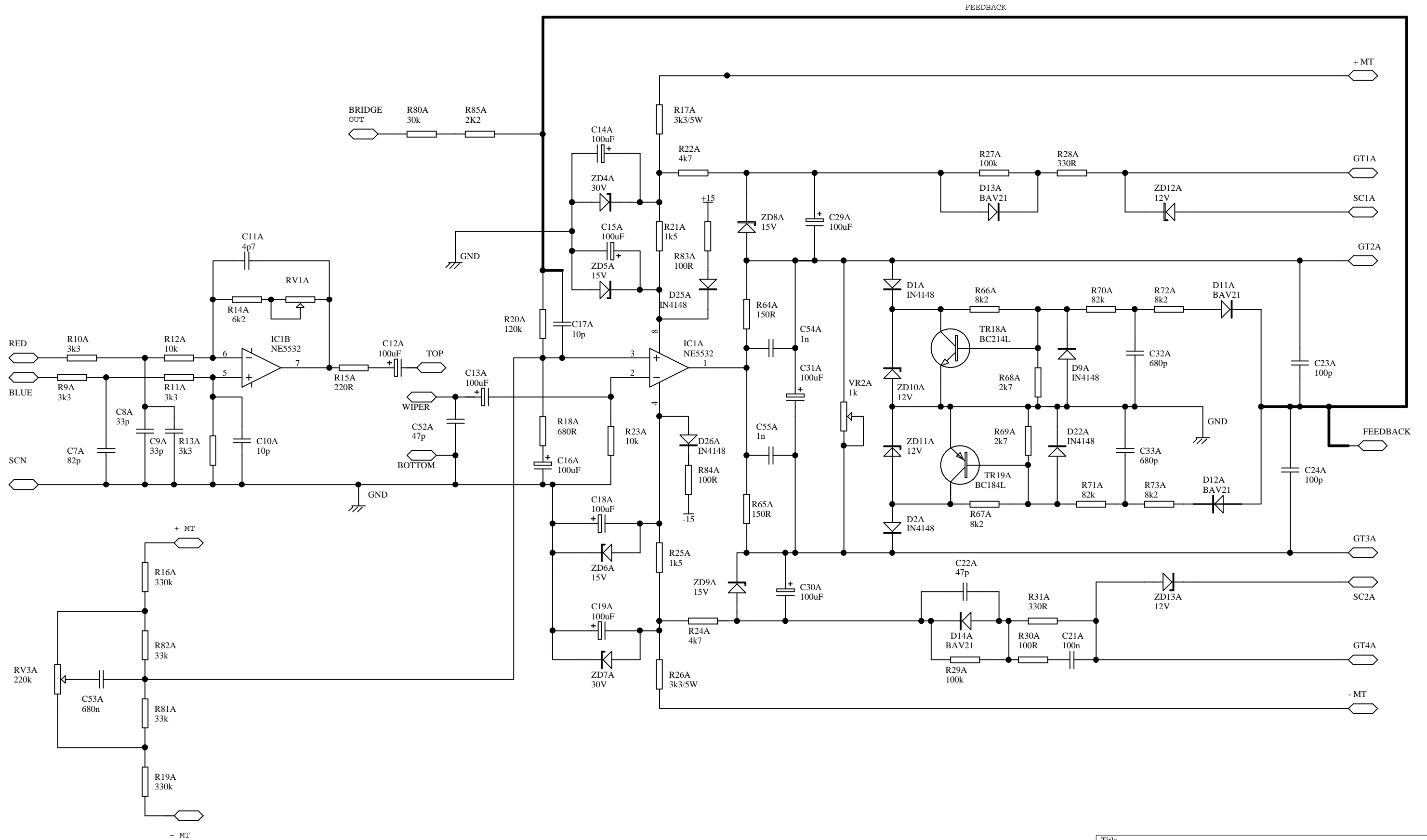

Title: <b>CHANNEL A DRIVER STAGE</b>			
Size: A3	Number: <b>C1048</b>	Revision: <b>1</b>	
Date: 1-Jul-1999	Sheet of 3	5	
File: D:\PROTEI\ST\ST1000\C1048.S03	Drawn By: LMB		



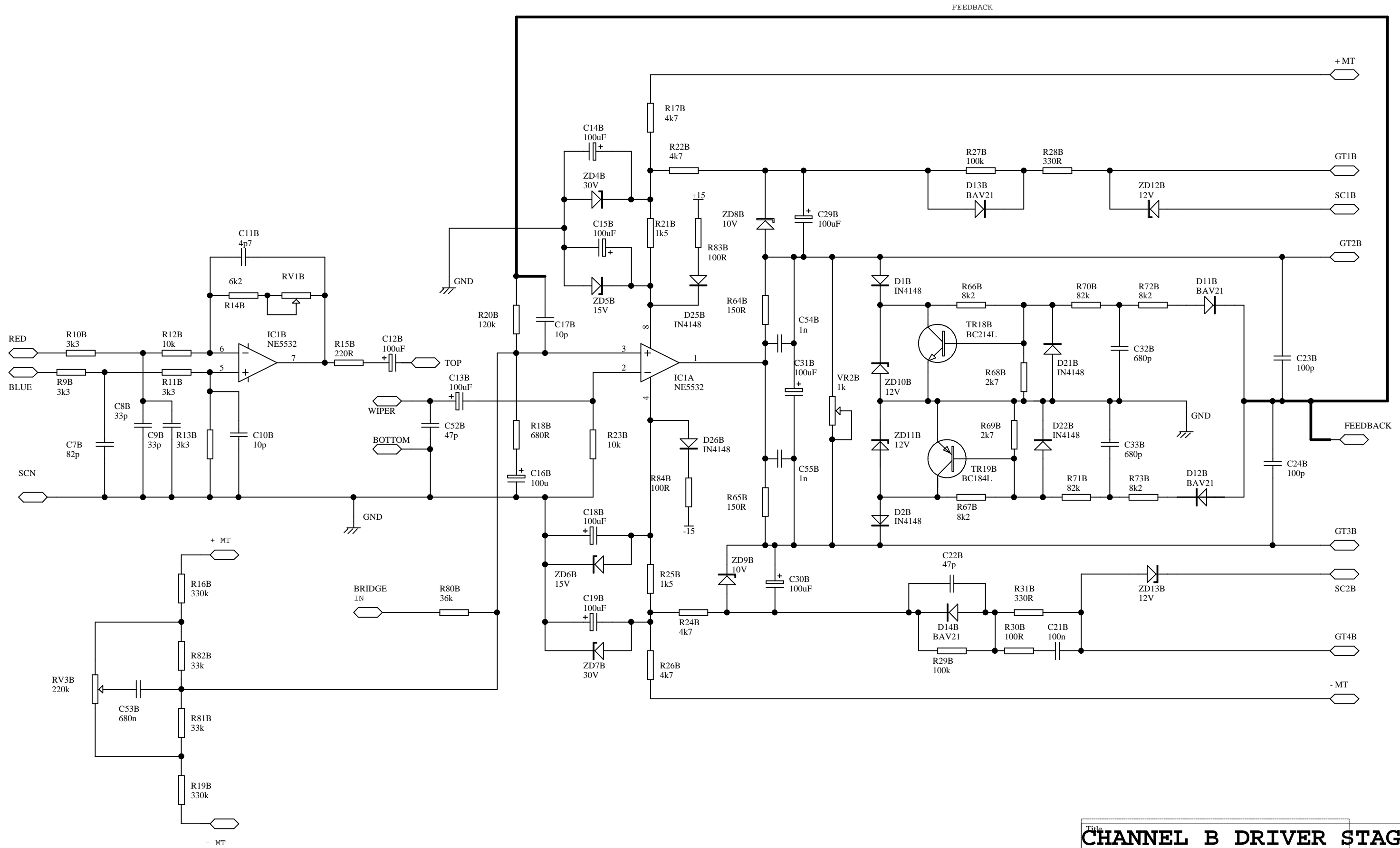

Title			
<b>CHANNEL B DRIVER STAGE</b>			
Size	Number	Revision	
A3	<b>C1048</b>	<b>1</b>	
Date:	1-Jul-1999	Sheet of	4 5
File:	D:\PROTEL\ST\ST1000\C1048.S04	Drawn By:	LMB

DRAWING OF OUTPUT STAGE  
 COMPONENT REFERENCES SHOULD  
 BE SUFFIXED WITH A OR B  
 FOR RESPECTIVE CHANNELS

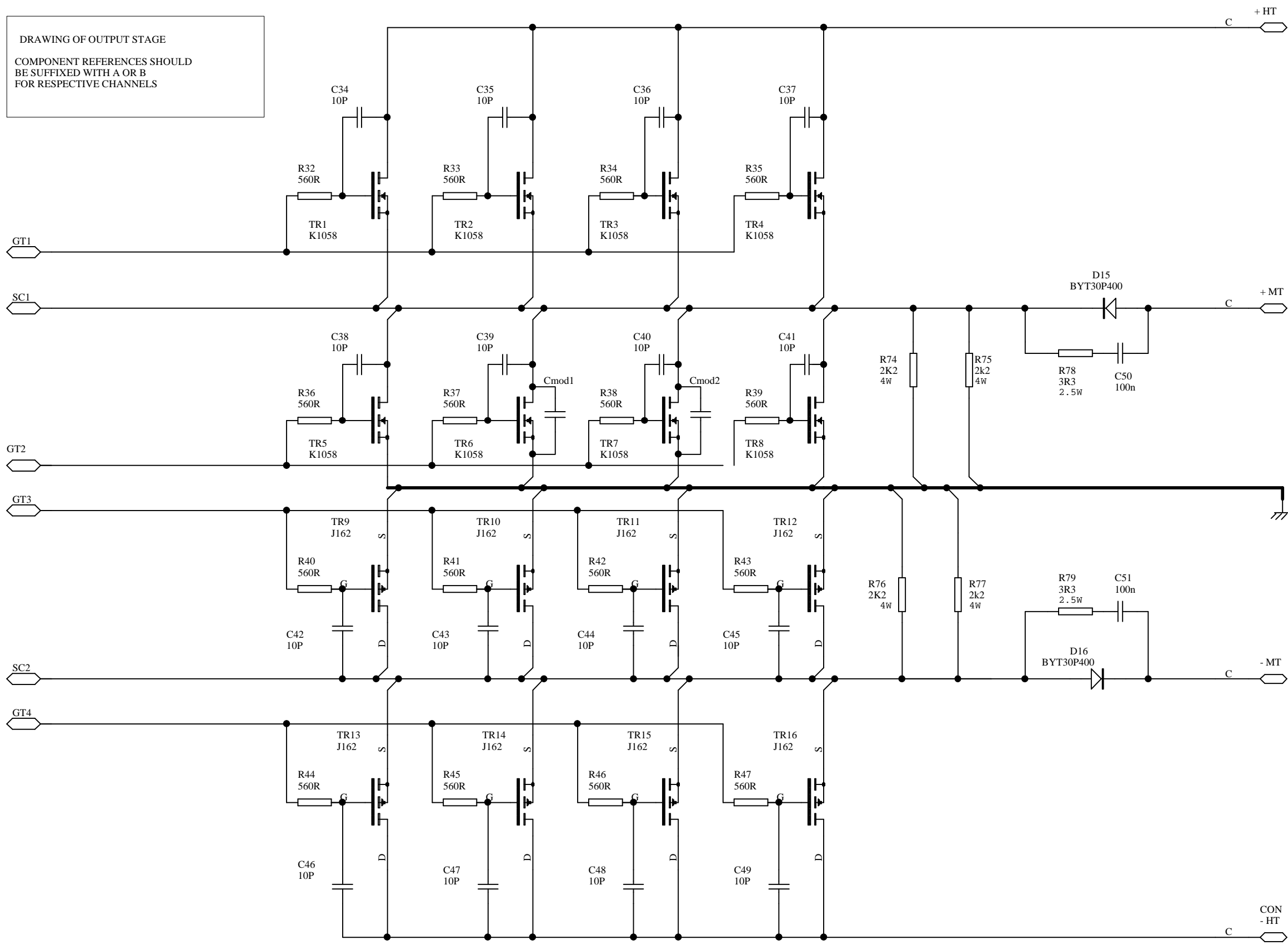

Title		<b>OUTPUT STAGE A/B</b>	
Size	Number	<b>C1048</b>	
	Revision	<b>1</b>	
Date:	1-Jul-1999	Sheet of	5 5
File:	D:\PROTEL\ST\ST1000\C1048.S05	Drawn By:	LMB

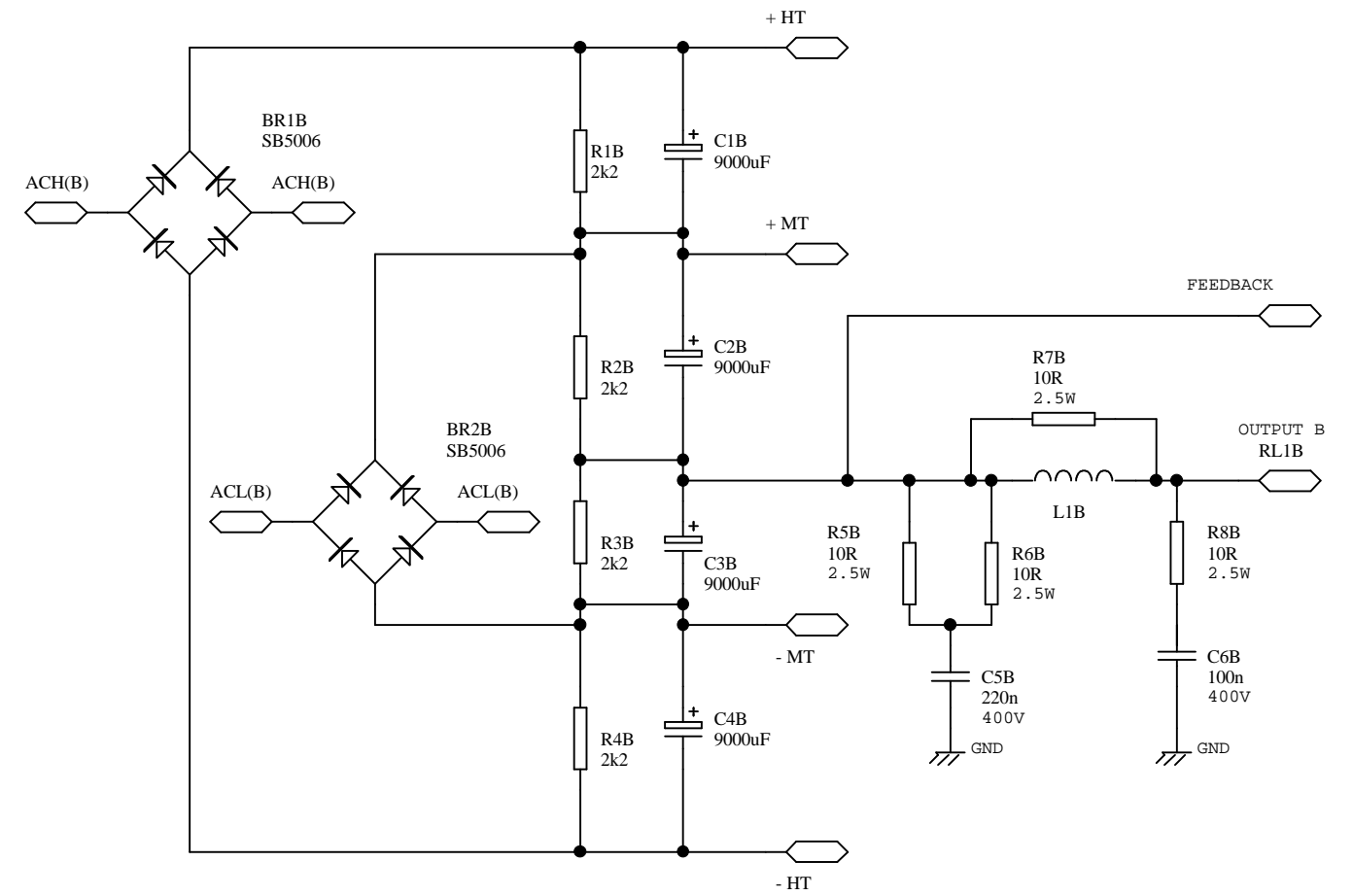
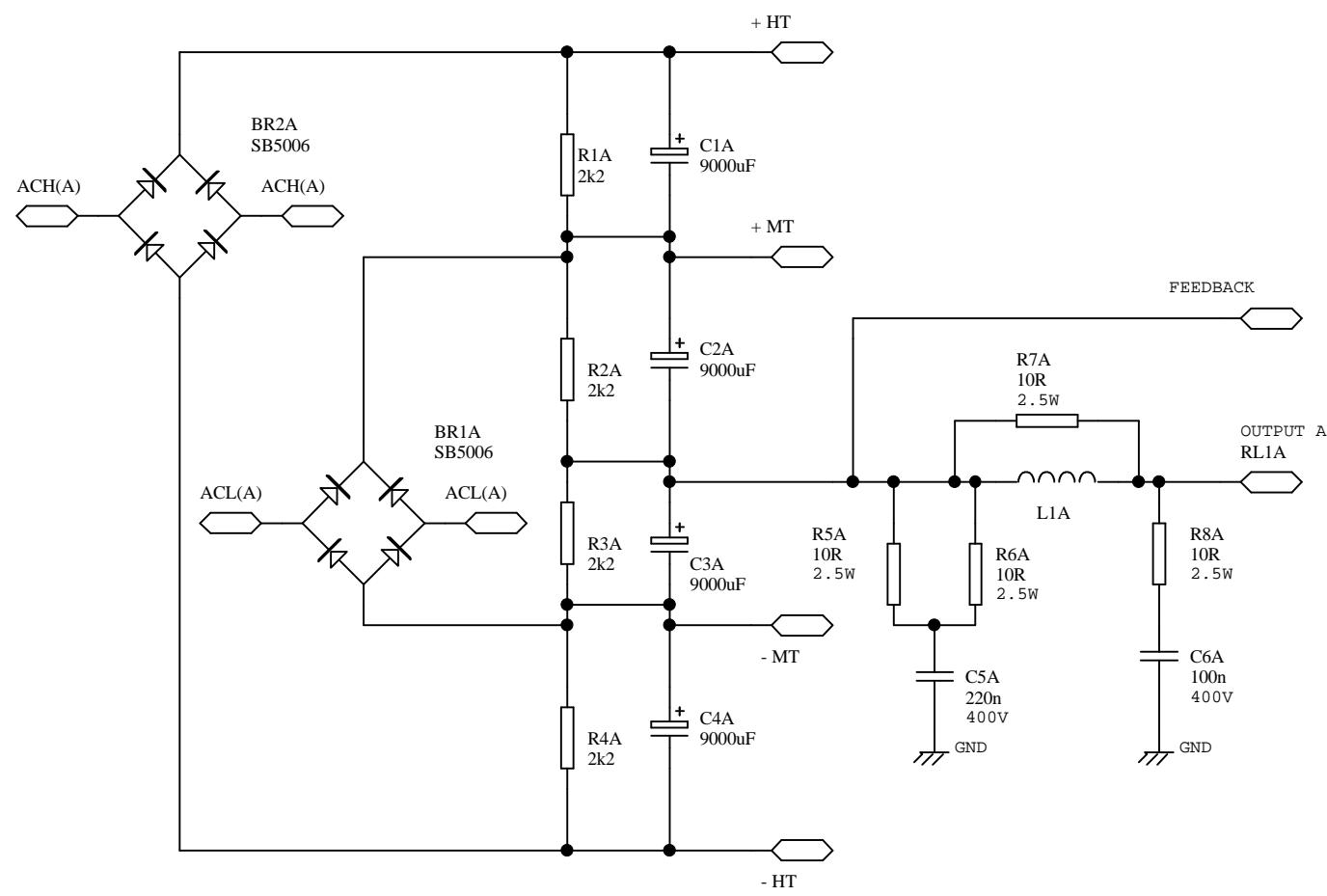

Title			
<b>POWER SUPPLY SECTION</b>			
Size	Number	Revision	
B	<b>C1048</b>	<b>1</b>	
Date:	1-Jul-1999	Sheet of	2 5
File:	D:\PROTEL\ST\1000\C1048.S02	Drawn By:	LMB

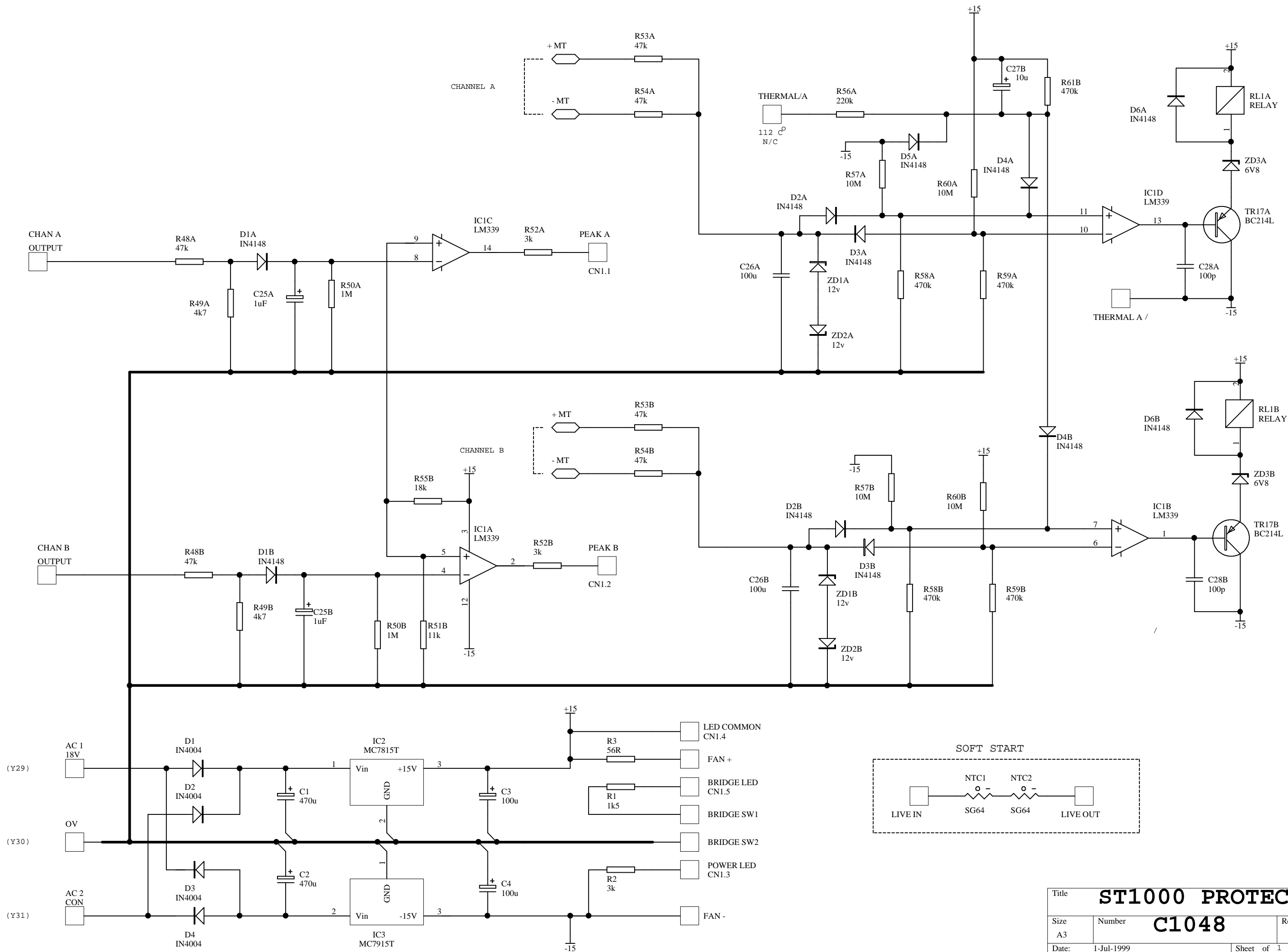

Title <b>ST1000 PROTECTION</b>		
Size <b>A3</b>	Number <b>C1048</b>	Revision <b>1</b>
Date: 1-Jul-1999	Sheet of 1 5	
File: D:\PROTEI\ST\ST1000\C1048.S01	Drawn By: LMB	

## ST Series Modification Procedure

### General

The following changes are to be made to **All** ST amplifiers irrespective of Issue :

- 1) Remove C20 & C28 (10pF) from the PCB and replace with 15pF, 50V ceramic capacitors.
- 2) Remove C10 & C32 (47pF) from the PCB and replace with 100pF, 50V ceramic capacitors.
- 3) Remove C17 & C40 (100nF) from the PCB and replace with 22nF, 250V polyester capacitors.
- 4) Remove C16 & C39 (220nF) from the PCB and replace with 47nF, 250V polyester capacitors.
- 5) Remove C12, C13, C35 & C36 from the PCB. **Note**, It is better to do this by cutting the component leads close to the PCB to avoid damaging PCB traces.
- 6) Fit 2 x 1N4148 diodes solder-side in reverse parallel from IC2 pin 3 to 0V, as per figure 1.
- 7) Fit 2 x 1N4148 diodes solder-side in reverse parallel from IC4 pin 3 to 0V, as per figure 1.
- 8) Remove any capacitors fitted on the solder-side of the PCB that connect to the middle pin of the Output transistors. **DO NOT** remove the 10pF capacitors fitted across the two outside pins of the K1058 transistors.
- 9) Fit 220pF, 1kV ceramic capacitors between Drain and Source of TR6 and TR17 as per figure 1.

### Issue Specific Changes

At this point, it is necessary to ascertain the exact issue status of the unit before proceeding, as follows:

- 1) Issue 6 PCBs: Go To Procedure 1.
- 2) Issue 4 & 5 PCBs fitted with P1040 & P1041 protection daughter boards: Go To Procedure 2.
- 3) Issue 4 & 5 PCBs fitted with Resistor-Resistor-Diode-Capacitor networks in positions R55, R56, R19 and R20: Go To Procedure 3.
- 4) Previous Issues: Go To Procedure 4.

## **Procedure 1 Issue 6 PCBs**

- 1) Remove R17, R22, R53 & R58 (5k6) from the PCB and replace with 5k1, 1/4W.
- 2) Remove R18, R21, R54 & R57 (1k8) from the PCB and replace with 5k1, 1/4W.
- 3) Remove ZD1, ZD2, ZD3 & ZD4 (12V) from the PCB and replace with 9V1 1/2W.
- 4) Fit 390k, 1/4W resistor solder-side between D40 Cathode and D41 Anode, as per figure 2.
- 5) Fit 390k, 1/4W resistor solder-side between D43 Cathode and D42 Anode, as per figure 2.

## Procedure 2 Issue 4 & 5 PCBs with Modification Daughter Boards

- 1) Remove R17, R22, R53 & R58 (5k6) from the PCB and replace with 5k1, 1/4W.
- 2) Remove ZD1, ZD2 & ZD3 (12V) from the PCB and replace with 9V1 1/2W.
- 3) Fit 9V1, 1/2W zener diode solder-side in position ZD4 as per figure 3.

### Modification to P1040 Daughter Board

- 1) Remove R18 & R21 (1k8) from the PCB and replace with 5k1, 1/4W.
- 2) Fit 390k, 1/4W resistor solder-side between D1 Cathode and D2 Anode, as per figure 4.

### Modification to P1041 Daughter Board

- 1) Remove R54 & R57 (1k8) from the PCB and replace with 5k1, 1/4W.
- 2) Fit 390k, 1/4W resistor solder-side between D2 Cathode and D1 Anode, as per figure 4.

Figure 4

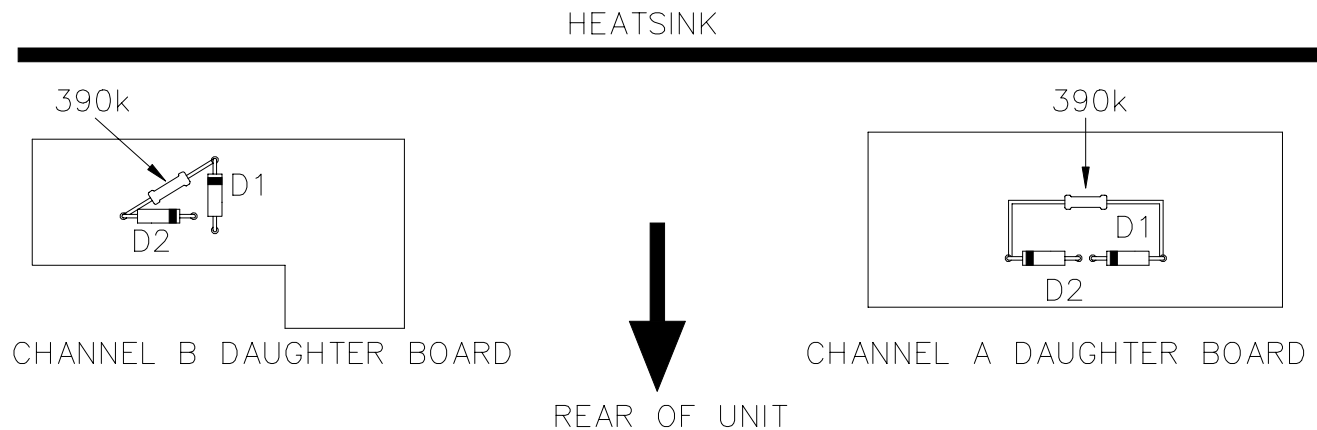

## Procedure 3 Issue 4 & 5 PCBs with Resistor-Resistor-Diode-Capacitor Networks

- 1) Remove R17, R22, R53 & R58 (5k6) from the PCB and replace with 5k1, 1/4W.
- 2) Remove R18, R21, R54 & R57 (1k8) from the PCB and replace with 5k1, 1/4W.
- 3) Remove ZD1, ZD2, ZD3 & ZD4 (12V) from the PCB and replace with 9V1 1/2W.
- 4) Fit 390k, 1/4W resistor between Component Network diodes as per figure 5.
- 5) Fit 390k, 1/4W resistor between Component Network diodes as per figure 5.

**Figure 5**

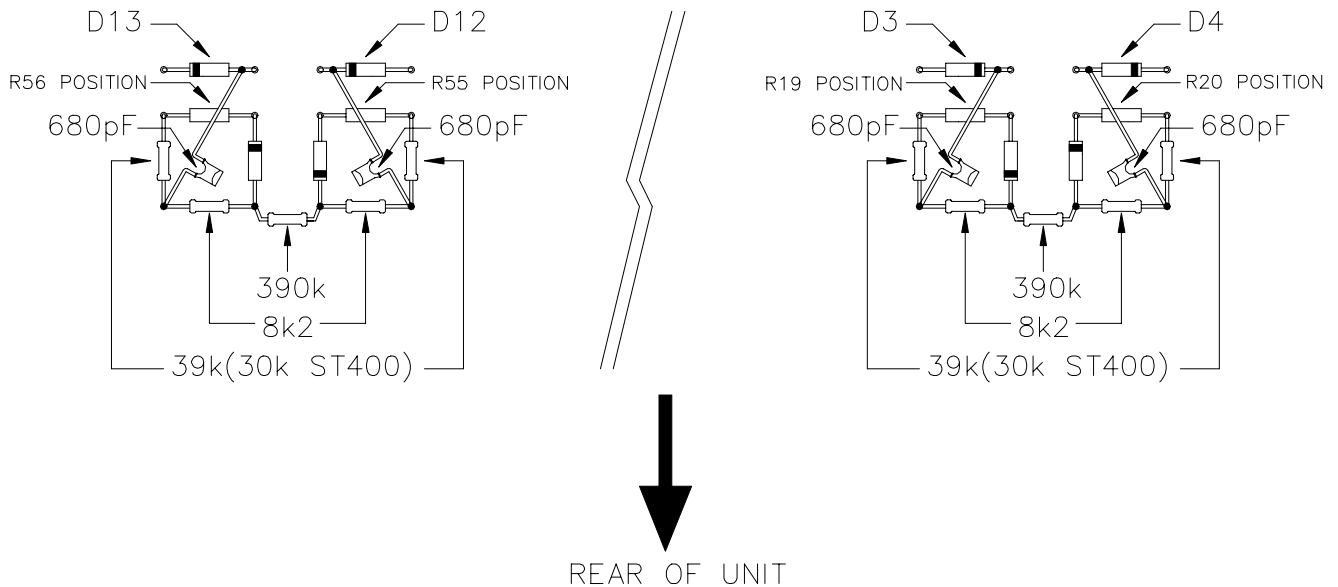

**Procedure 4**



- 1) Remove R17, R22, R53 & R58 (5k6) from the PCB and replace with 5k1, 1/4W.
- 2) Remove R18, R21, R54 & R57 (1k8) from the PCB and replace with 5k1, 1/4W.
- 3) Remove ZD1, ZD2, ZD3 & ZD4 (12V) from the PCB and replace with 9V1 1/2W.
- 4) Remove Components fitted in positions R19, R20, R55 & R56 and replace with networks consisting of 1N4004 diodes, 8k2 resistors, 39k resistors, 680pF capacitors and 390k resistors as per figure 6.
- 5) Remove the fixing screws for the K1058 output transistors and remove the insulating pad between the transistor and the heatsink.
- 6) Rub-down the heatsink with medium abrasive paper to remove any burrs or remnants of insulating pad.
- 7) Ensure the mounting faces of the power transistors are clean and then apply a thin, even layer of heatsink compound to the device and re-assemble the devices onto the heatsink. Ensure the fixing screws are secure but take care not to over-tighten.

**Figure 6**

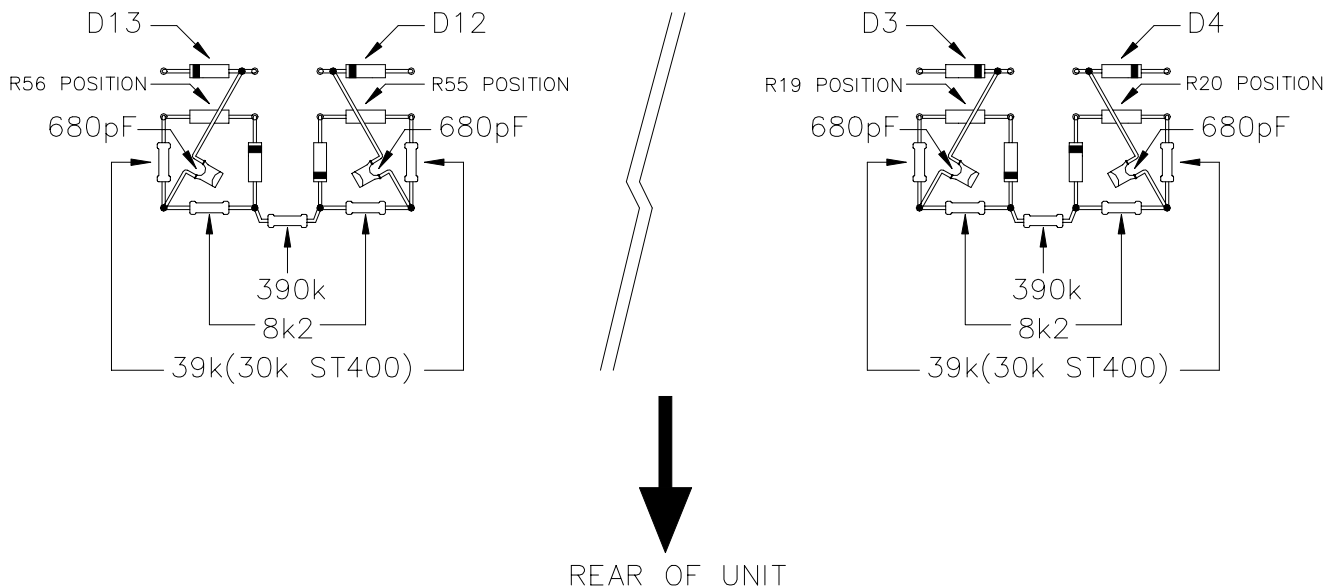

**General notes**

Once the appropriate modifications have been carried out it is recommended that the following checks are performed before attempting to re-test the amplifier.

- 1) **Output Stage** : Check for faulty Output transistors in the following way :
  - a) Measure between Drain and Source of each transistor with a multi-meter set on a low Ohms range. A short-circuit reading indicates one or more transistors is faulty.
  - b) Measure between Gate and Source of each transistor with a multi-meter set on the 2k Ohms range. A reading of less than 560 Ohms indicates a faulty transistor.
- 2) **Zobel Resistors** : Check R34, R35, R106, R69, R71 & R109. Replace with the correct 10R, 2.5W parts if faulty, or show any signs of having over-heated.

### **Final Checks**

Once the amplifier has been modified and repaired it is always possible that there remains one or more components which have been weakened or damaged by any previous failure. The easiest way to confirm all is well is to perform a simple short-circuit test on the amplifier as follows : Drive the amplifier into a 4 Ohm load to an output level just prior to the clip point. Connect a short circuit across the amplifier output for a period of approximately ten seconds. Remove the short circuit and check the output returns to its previous level. If any Output transistors fail during this test, they should be replaced, but output transistors continue to fail (especially if they are recently replaced parts) the current limiting protection circuits should be checked for faulty components.

FIGURE 2

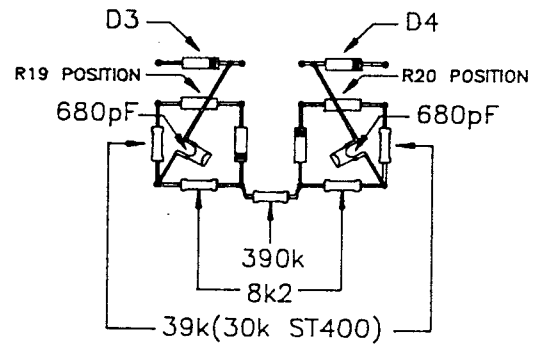
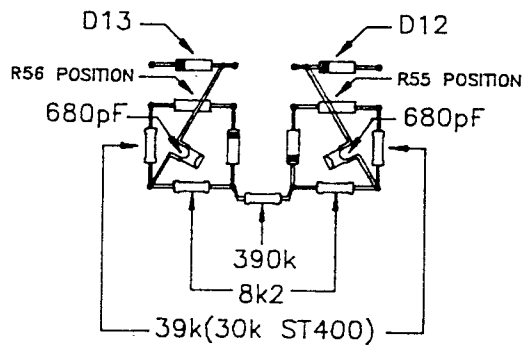

REAR OF UNIT

FIGURE 1

FIT CAPACITOR DIRECTLY TO MOS-FET LEADS AS SHOWN, AND BEND THROUGH 90° TOWARDS REAR OF UNIT AS SHOWN.

FIT CAPACITOR DIRECTLY TO MOS-FET LEADS AS SHOWN, AND BEND THROUGH 90° TOWARDS REAR OF UNIT AS SHOWN.

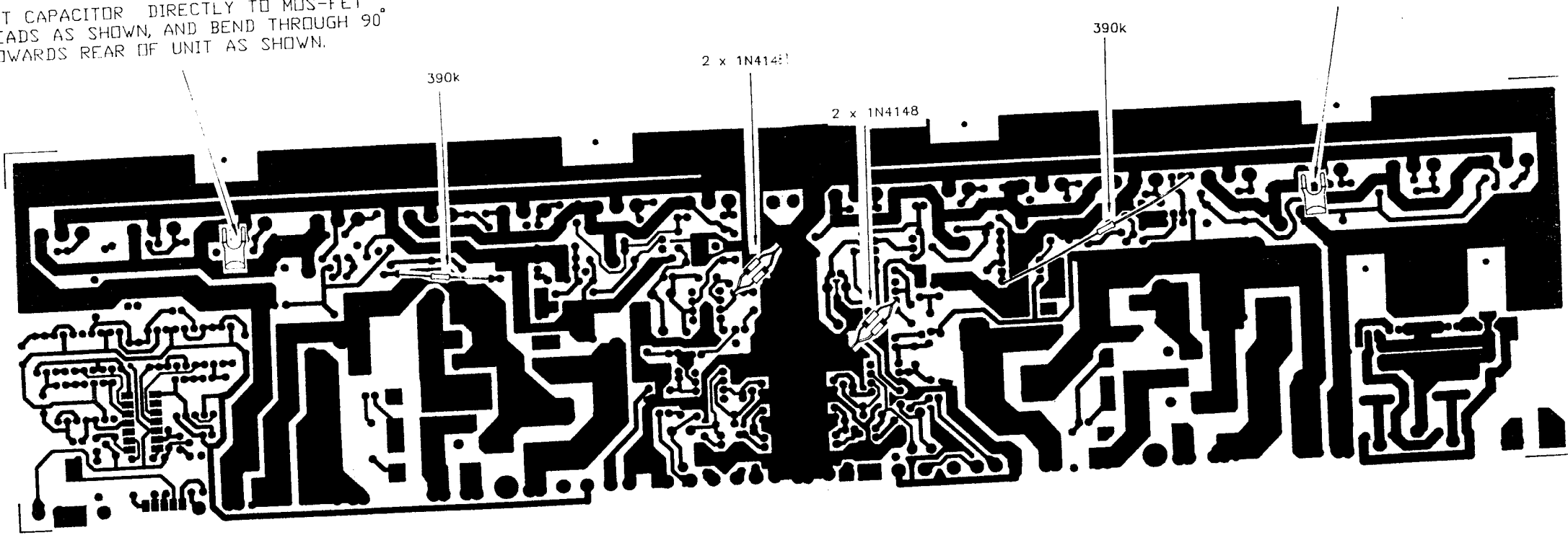

FIGURE 3

FIT CAPACITOR DIRECTLY TO MOS-FET  
LEADS AS SHOWN, AND BEND THROUGH 90°  
TOWARDS REAR OF UNIT AS SHOWN.

FIT CAPACITOR DIRECTLY TO MOS-FET  
LEADS AS SHOWN, AND BEND THROUGH 90°  
TOWARDS REAR OF UNIT AS SHOWN.

2 x 1N4148

2 x 1N4148

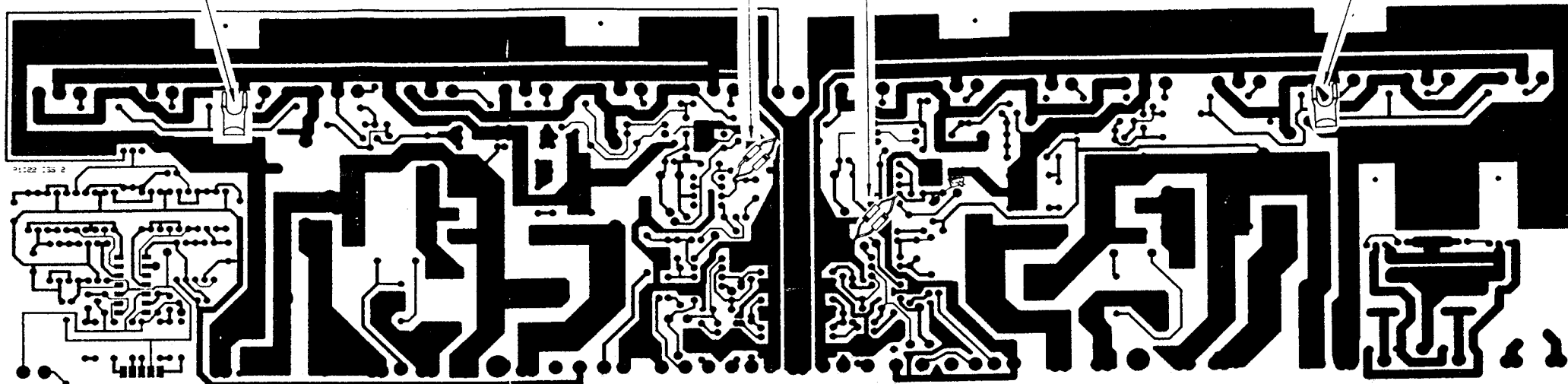

TESTED

AUDIO

P1022 ISS B  
P1022 ISS B

287202-124

10 081PISA

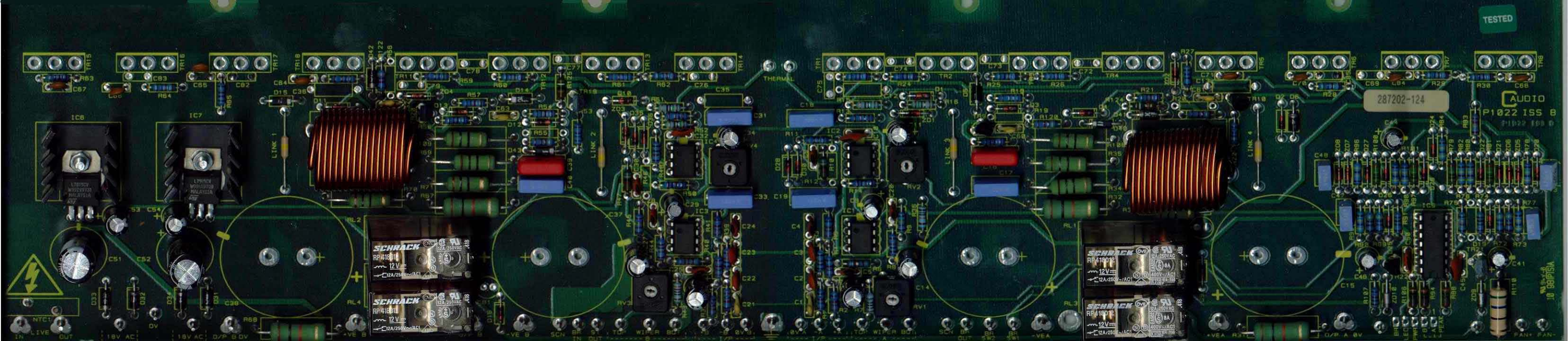

**SCHRACK**  
RP 418012  
12V  
12A/250V~AC1

**SCHRACK**  
RP 418012  
12V  
12A/250V~AC1

**SCHRACK**  
RP 418012  
12V  
12A/250V~AC1

**SCHRACK**  
RP 418012  
12V  
12A/250V~AC1



IN LIVE OUT  
18V AC  
D/P 0 DV

18V AC  
D/P 0 DV

18V AC  
D/P 0 DV

18V AC  
D/P 0 DV

18V AC  
D/P 0 DV

18V AC  
D/P 0 DV

18V AC  
D/P 0 DV

18V AC  
D/P 0 DV

18V AC  
D/P 0 DV

18V AC  
D/P 0 DV

REPLACE  
C28 WITH  
15 PF

REPLACE  
C20 WITH  
15 PF

REPLACE  
C40 WITH  
22N  
C39 WITH  
47N

REPLACE  
C17 WITH  
22N  
C16 WITH  
47N

REMOVE  
C36 100PF

REPLACE  
C82 WITH  
100 PF

REPLACE  
C10 WITH  
100 PF

REMOVE  
C13

REMOVE  
C35  
C12

5 6  
FIT C220  
2KV ACROSS  
PINS 5+6

8 9  
FIT C220  
2KV ACROSS  
PINS 8+9

8 7  
FIT C220  
2KV ACROSS  
PINS 8+7

5 4  
FIT C220  
2KV ACROSS  
PINS 5+4